



Designation: **F3326–19 F3326 – 19a**

Standard Specification for Flame Mitigation Devices on Portable Fuel Containers¹

This standard is issued under the fixed designation F3326; the number immediately following the designation indicates the year of original adoption or, in the case of revision, the year of last revision. A number in parentheses indicates the year of last reapproval. A superscript epsilon (ϵ) indicates an editorial change since the last revision or reapproval.

1. Scope

1.1 This specification establishes performance requirements for Flame Mitigation Devices (FMDs) in portable fuel containers (PFCs) for gasoline, kerosene, and diesel fuels intended for reuse by the consumer.

1.2 A flame mitigation device in gasoline (red), diesel (yellow), and kerosene (blue) PFCs protects the container openings from possible propagation of a flame into a flammable fuel-air mixture within the container. Formation of a flammable fuel-air mixture in the container can occur in special circumstances associated with cold ambient conditions and low liquid levels in the container. Delineations of those circumstances and conditions have been described in published reports (for example, Gardiner et al, 2010 (1), and papers, for example, Elias et al, 2013 (2), including research sponsored and overseen by the ASTM F15.10 Technical Committee.

1.3 This specification does not address the hazard of injury or death caused by ignition of vapors external to the PFC when the fuel in the PFC is poured onto or near to a fire or other ignition source causing these external vapors to ignite or explode. An FMD does not prevent hazards associated with misuse of the PFC resulting in external vapor ignition.

1.4 The flame mitigation device is chemically conditioned by exposure to representative fuel surrogates CE25a and CE85a fuel and other expected conditions prior to the tests.

1.5 The flame mitigation device is mechanically conditioned by repeated insertions and removal of a fuel refueling spout prior to the tests.

1.6 The first test method establishes that the flame mitigation device can effectively prevent flame propagation into a flammable butane-air mixture inside the portable fuel container. The butane-air mixture is a controlled and repeatable proxy for the more variable fuel vapor-air mixture in the container.

1.7 The second test method establishes that the flame mitigation device is permitting adequate flow rates of fuel.

1.8 This specification states values in SI units which are to be regarded as the standard. The values given in parentheses are for information only.

1.9 *This standard does not purport to address all of the safety concerns, if any, associated with its use. It is the responsibility of the user of this standard to establish appropriate safety, health, and environmental practices and determine the applicability of regulatory limitations prior to use.*

1.10 *This international standard was developed in accordance with internationally recognized principles on standardization established in the Decision on Principles for the Development of International Standards, Guides and Recommendations issued by the World Trade Organization Technical Barriers to Trade (TBT) Committee.*

2. Referenced Documents

2.1 *ASTM Standards:*²

F852 Specification for Portable Gasoline Containers for Consumer Use (Withdrawn 2017)³

¹ This specification is under the jurisdiction of ASTM Committee F15 on Consumer Products and is the direct responsibility of Subcommittee F15.10 on Standards for Flammable Liquid Containers.

Current edition approved Jan. 1, 2019; May 15, 2019. Published January 2019. Originally approved in 2019. Last previous edition approved in 2019 as F3326 – 19. DOI: 10.1520/F3326-19.10.1520/F3326-19A.

² For referenced ASTM standards, visit the ASTM website, www.astm.org, or contact ASTM Customer Service at service@astm.org. For *Annual Book of ASTM Standards* volume information, refer to the standard's Document Summary page on the ASTM website.

³ The last approved version of this historical standard is referenced on www.astm.org.

2.2 Other Standards:

NFPA 497 Recommended Practice for the Classification of Flammable Liquids, Gases, or Vapors of Hazardous (Classified) Locations for Electrical Installations in Chemical Process Areas⁴

IEC 60079-20-1 Explosive atmospheres – Part 20-1: Material characteristics for gas and vapour classification – Test methods and data⁵

CSA B376 Portable Containers for Gasoline and Other Petroleum⁶

3. Terminology

3.1 Specification **F852** is the reference for all portable fuel container specific terminology in this specification. Definitions may be presented in this section for convenience.

3.2 Definitions:

3.2.1 *flame mitigation device (FMD)*, *n*—a device permanently installed in a PFC to prevent the propagation of an external ignition into the PFC.

3.2.2 *flame speed*, *n*—the average frame to frame measured speed of the flame in the first $\frac{3}{4}$ of the tube length.

3.2.3 *fuel*, *n*—a volatile mixture of liquid petroleum hydrocarbons distillates, and small amounts of additives, sometimes blended with ethanol or similar oxygenates, suitable for use as a fuel in spark-ignition, internal combustion gasoline engines), or bio diesel (for compression ignition in diesel engines).

3.2.4 *Maximum Experimental Safe Gap (MESG)*, *n*—the maximum clearance between two parallel metal surfaces that has been found, under specified test conditions, to prevent a deflagration in a test chamber from being propagated to a secondary chamber containing the same gas or vapor at the same concentration (see IEC 60079-20-1).

3.2.5 *portable fuel container (PFC)*, *n*—a single- or multi-compartment vessel intended for use by consumers to transport gasoline, gas/oil mixtures (or separate compartments of gas and oil), diesel, or kerosene from their distribution points to the consumer's storage and use points, including all of the components intended for use on or with the container including those supplied by manufacturers other than the PFC manufacturer.

4. FMD Requirements

4.1 General Requirements:

4.1.1 The PFC shall be qualified to the current version of Specification A flame mitigation device shall be provided in each PFC opening to protect the container opening(s) from possible propagation of a **F852** flame into a flammable fuel-air mixture within the container.

4.1.2 Due to the increased risk of static discharge with more conductive materials, the FMD shall be composed of nonmetallic materials.

4.1.3 The PFC with the highest rated capacity up to 5 gal or 20 L of a family of similar design and construction shall be representative of all of the PFCs within that family with respect to this specification.

NOTE 1—The PFC with the highest rated capacity in the family may be used to certify all of the PFCs in the family.

NOTE 2—This FMD standard may be referenced for other container capacities and applications.

4.2 FMD Effectiveness:

4.2.1 When tested in accordance with **6.1**, a PFC which has undergone test method 8.3 of Specification **F852**, Drop Strength Test using water only:

4.2.1.1 Shall not allow a flame to propagate into and ignite the headspace within the PFC with the pouring spout installed according to the manufacturer's instructions.

4.2.1.2 If the pouring spout is removable, shall not allow a flame to propagate into and ignite the headspace within the PFC with the pouring spout removed.

4.2.1.3 If there are separate openings for filling and pouring, shall not allow a flame to propagate into and ignite the headspace within the PFC through the filling opening.

4.2.2 When tested in accordance with **6.1**, a PFC which has undergone test method 8.4 of Specification **F852**, Hydrostatic Pressure Test:

4.2.2.1 Shall not allow a flame to propagate into and ignite the headspace within the PFC with the pouring spout installed according to the manufacturer's instructions.

4.2.2.2 If the pouring spout is removable, shall not allow a flame to propagate into and ignite the headspace within the PFC with the pouring spout removed.

4.2.2.3 If there are separate openings for filling and pouring, shall not allow a flame to propagate into and ignite the headspace within the PFC through the filling opening.

⁴ Available from National Fire Protection Association (NFPA), 1 Batterymarch Park, Quincy, MA 02169-7471, <http://www.nfpa.org>.

⁵ Available from International Electrotechnical Commission (IEC), 3, rue de Varembe, 1st Floor, P.O. Box 131, CH-1211, Geneva 20, Switzerland, <http://www.iec.ch>.

⁶ Available from Canadian Standards Association (CSA), 178 Rexdale Blvd., Toronto, ON M9W 1R3, Canada, <http://www.csagroup.org>.

4.2.3 When tested in accordance with 6.1, a new, unused PFC chemically conditioned in accordance to 5.1 using Standard Fuel CE25a, then mechanically conditioned in accordance to 5.2 and tested within 48 h of the chemical conditioning:

4.2.3.1 Shall not allow a flame to propagate into and ignite the headspace within the PFC over the course of five (5) successive tests within 8 h with the pouring spout installed according to the manufacturer's instructions.

4.2.3.2 If the pouring spout is removable, shall not allow a flame to propagate into and ignite the headspace within the PFC over the course of five (5) successive tests within 8 h with the pouring spout removed.

4.2.3.3 If there are separate openings for filling and pouring, shall not allow a flame to propagate into and ignite the headspace within the PFC through the filling opening over the course of five (5) successive tests within 8 h.

NOTE 3—It is permissible to use the same conditioned PFC as used in 4.3.1.

4.2.4 When tested in accordance with 6.1, a new, unused PFC chemically conditioned in accordance to 5.1 using Standard Fuel CE85a, then mechanically conditioned in accordance to 5.2 and tested within 48 h of the chemical conditioning:

4.2.4.1 Shall not allow a flame to propagate into and ignite the headspace within the PFC over the course of five (5) successive tests within 8 h with the pouring spout installed according to the manufacturer's instructions.

4.2.4.2 If the pouring spout is removable, shall not allow a flame to propagate into and ignite the headspace within the PFC over the course of five (5) successive tests within 8 h with the pouring spout removed.

4.2.4.3 If there are separate openings for filling and pouring, shall not allow a flame to propagate into and ignite the headspace within the PFC through the filling opening over the course of five (5) successive tests within 8 h.

NOTE 4—It is permissible to use the same conditioned PFC as used in 4.3.2.

4.3 FMD Flow Resistance:

4.3.1 A new, unused PFC chemically conditioned in accordance to 5.1 using Standard Fuel CE25a, then mechanically conditioned in accordance to 5.2:

4.3.1.1 When tested in accordance with 6.2.3 shall have a pour-in rate not less than 34 L/min (9 gal/min).

NOTE 5—It is permissible to use this conditioned PFC for 4.2.3.

4.3.2 A new, unused PFC chemically conditioned in accordance to 5.1 using Standard Fuel CE85a, then mechanically conditioned in accordance to 5.2:

4.3.2.1 When tested in accordance with 6.2.3 shall have a pour-in rate not less than 34 L/min (9 gal/min).

NOTE 6—It is permissible to use this conditioned PFC for 4.2.4.

4.4 Flow Out Test [Reserved]:

NOTE 7—If applicable, a requirement regarding the pouring out rate, intended to ensure that the pouring out flow characteristic of an FMD equipped PFC does not adversely affect consumer acceptance, may be incorporated in a later version of this specification.

4.5 FMD Removal:

4.5.1 When tested in accordance with 6.3, the FMD shall not be removed from the PFC.

4.6 Retest Statement:

4.6.1 ~~Testing Requirements—Full~~ No qualification testing shall be required to certify products to this initial version of this specification is required as a result of this revision.

5. Sample Preparation/Conditioning

5.1 PFC FMD Test Sample Chemical Durability Conditioning:

5.1.1 *Chemical Conditioning Purpose*—The FMD equipped PFC is conditioned with Standard Fuel CE25a and CE85a to verify that the FMD structure and effectiveness is not compromised by prolonged exposure to the specified fuel formulations.

5.1.2 *Chemical Durability Conditioning Apparatus:*

5.1.2.1 A PFC and fuel.

5.1.2.2 A PFC temperature controlled enclosure capable of maintaining and monitoring a constant temperature of $40 \pm 2^\circ\text{C}$ ($104 \pm 4^\circ\text{F}$) near the PFC location is used for the PFC thermal environment.

5.1.3 *Chemical Conditioning Procedure:*

5.1.3.1 Fill the PFC with fuel such that approximately 50 % of the length of the FMD in the filling opening is immersed in test fuel.

5.1.3.2 Secure closures with the torque values specified in Specification F852 Table 1.

5.1.3.3 Place PFC into the enclosure with a controlled temperature of $40 \pm 2^\circ\text{C}$ ($104 \pm 4^\circ\text{F}$), as measured near the PFC.

5.1.3.4 Store in enclosure for a minimum of 60 days. Once each weekday during storage, remove PFC from enclosure, shake PFC so that the liquid will contact the FMD situated in the filling opening, and return to enclosure.

5.1.3.5 Remove PFC after at least 60 days.

5.1.3.6 Examine and photograph applicable FMDs within 4 h, noting any deterioration or changes in dimensions or shape.

NOTE 8—It is permissible to make intermediate examinations of the FMD to determine if obvious physical damage has clearly rendered it ineffective.

5.2 PFC FMD Mechanical Durability Conditioning:

5.2.1 This mechanical durability conditioning is carried out on the FMD in the filling opening after the 5.1 chemical conditioning.

5.2.2 Mechanical Durability Conditioning Apparatus—A commercial type fuel dispensing nozzle is mounted on a surface inclined at an angle of 45° to the horizontal so that it can slide into the filling opening of an FMD equipped PFC, which is also mounted on an inclined surface oriented perpendicular to the nozzle spout slide. Use a fixture equivalent to a standard nozzle of 29 mm (1 1/8 in.) in diameter, weighing 1320 g (2.91 lb) and approximately 18 cm (7 in.) in length. Appendix X2, Fig. X2.1 is an illustrative example of the apparatus setup for this conditioning.

5.2.3 Mechanical Durability Conditioning Procedure—Allow the nozzle to slide via gravity into filling opening of the fuel container, and then retrieved and repositioned on the inclined surface. This conditioning procedure simulates the mechanical wear due to friction between nozzle and the PFC opening containing the FMD. Repeat the insertion and retrieval process 49 times.

NOTE 9—It is permissible to make intermediate examinations of the FMD to determine if obvious physical damage has clearly rendered it ineffective.

6. Test Methods

6.1 FMD Effectiveness Test:

NOTE 10—FMD effectiveness tests are carried out within 48 h of chemical conditioning.

6.1.1 The bottom of an FMD equipped PFC is cut off and the PFC is mounted to a base plate containing a gas sampling port and an aluminum foil blow out panel. Fill the modified PFC, with the pouring spout locked open where applicable, with a flammable butane-air mixture (simulating the fuel-air mixture) which also fills an igniter tube attached to the opening being tested. The orientation of the test setup positions the ignitor tube approximately horizontally. Expose the FMD under test to flame as described in 6.1.4. The configurations with and without spout are illustrated in Fig. 1.

6.1.2 Hazards—Ignition of a flammable vapor-air mixture, as is required in the FMD effectiveness test, inevitably entails fire and explosion hazards. Laboratory personnel responsible for these tests need to have training and experience in conducting tests with flammable vapors.

6.1.3 Test Apparatus and Setup:

6.1.3.1 Fig. 1 shows the test apparatus set up.

6.1.3.2 Cut off the bottom of the FMD equipped PFC so that the FMD being tested clears the mounting plate by 2 to 5 cm. Mount the PFC on a rigid base plate containing an opening for the exhaust gas vent tube connection and an approximately 100 mm diameter blowout panel comprised of standard household aluminum foil with a thickness of approximately 0.016 mm.

NOTE 11—It is recommended that exhaust gas tube connection is located in the lower elevation of the mounting plate.

6.1.3.3 A source of dry air, flowed through a controller capable of constant flow, to mix with fuel vapor.

6.1.3.4 A source of n-butane, flowed through a controller capable of constant flow, to mix with air.

6.1.3.5 A source of air or nitrogen to purge PFC.

6.1.3.6 A transparent polycarbonate tube, sealed at both ends, in which the flame is propagated from the ignitor to the FMD being tested. For spout on, mount the end of the tube flush to the edge of the stopper.

NOTE 12—A tube of 120 ± 5 mm long, with internal diameter equal to 50 ± 5 mm for spout on (Fig. 1a) and an internal diameter equal to the opening size of the PFC (± 5 mm) for spout off (Fig. 1b) has been shown to produce flame speeds in the desired range.

6.1.3.7 A remotely actuated spark ignitor to ignite the n-butane air mixture, held at a distance of 107 ± 10 mm from the entrance to the container (either with spout on or spout off).

6.1.3.8 A means to validate, for each FMD testing configuration, that a flame speed of 5.0 ± 1.0 m/s is achieved in the testing configuration.

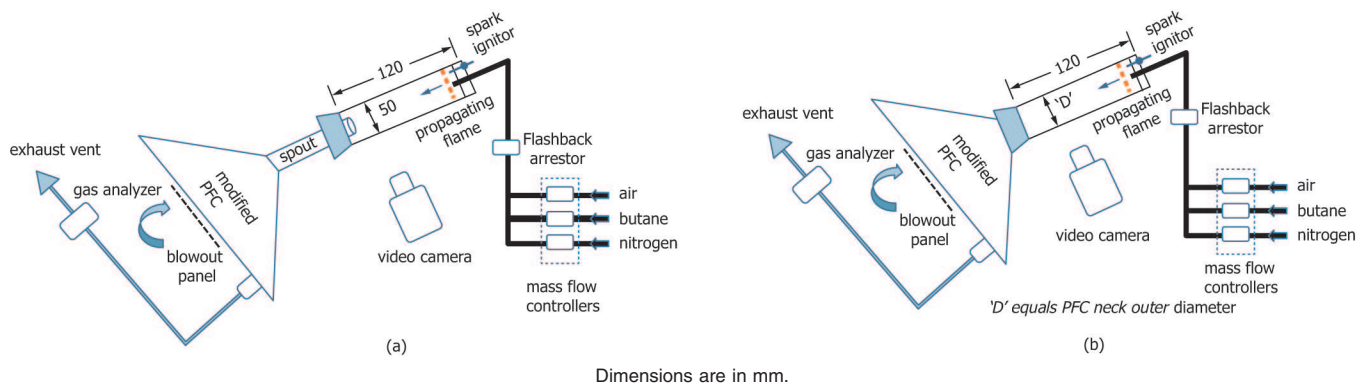

FIG. 1 FMD Effectiveness Test Apparatus (a) With Spout On (b) With Spout Off

6.1.3.9 An in-line flashback arrestor rated for Group D flammable mixtures installed to prevent propagation of a flame to the flow controllers.

6.1.3.10 Tubing to flow air, n-butane, and nitrogen.

6.1.3.11 A video camera capable of determining if the flame traversed the transparent tube and reached the FMD.

6.1.4 *Test Procedure:*

6.1.4.1 Conduct the FMD effectiveness test on the modified PFC, mounted on the test rig frame (see example photo in [Appendix X1](#)) with the ignition tube installed. A 5 min stabilization after a prior ignition test on the same modified PFC is necessary. Lock the spout auto close feature open, where applicable.

6.1.4.2 Purge the PFC and fill with a butane-air mixture which has been validated at the start of testing to provide the target flame speed of 5.0 ± 1.0 m/s.

6.1.4.3 Leave the exhaust tube open. Isolate or disconnect the inlet tube to prevent backflash from damaging the instrumentation.

6.1.4.4 Initiate video recording.

6.1.4.5 Energize the igniter.

6.1.4.6 Ensure that the butane-air mixture inside the polycarbonate tube has ignited and that the flame has reached the FMD.

6.1.4.7 Observe for overpressure in the container indicating ignition inside the PFC.

NOTE 13—Overpressure may be indicated by release of the blowout panel, discharge in the outlet tube or other means.

6.1.4.8 After 5 s purge with air to reach an ambient oxygen concentration.

6.2 *FMD Flow Resistance Tests:*

6.2.1 *Summary*—The maximum flow rate of water during filling with the FMD equipped PFC is determined.

6.2.2 *Flow Resistance Test Apparatus and Setup:*

6.2.2.1 Perform the flow resistance tests with water or gasoline.

6.2.2.2 A pump with a flow capacity of at least 38 L/min (10 gal/min) with an outlet line ending in a 2 cm (0.78 in.) diameter typical gasoline dispensing nozzle is used for the pour-in test.

6.2.2.3 A device to measure the weight, or volume, of water that flows into the PFC and the duration, as a basis for flow rate calculation, or to make a direct measurement of the steady state flow rate.

6.2.3 *In-Flow Resistance Test Procedure*—Pump approximately 75 % of the PFC rated capacity with water into the filling opening of the FMD equipped PFC. Average the flow rate over three test results.

6.3 *FMD Removal*—This test demonstrates that the FMD installation can resist removal in a manner reflecting consumer attempts to remove it without the use of tools. (See [Appendix X4](#).)

6.3.1 *FMD Push-in*—Restrain the PFC and subject the FMD in the opening to an inward or pushing force of 67 N (15 lb) applied to the FMD.

6.3.2 *FMD Pullout*—Restrain the PFC and subject the FMD in the opening to an outward or pulling force of 67 N (15 lb) pounds applied with a clamping fixture on the lip or other protrusion or gap in the FMD mounting. It is also acceptable to apply the force to the outside of the bottom of the FMD.

7. Precision and Bias

7.1 The test methods in this standard are pass or fail only and not intended to be used to determine physical properties of PFCs or FMDs.

8. Significance and Limitations

8.1 N-butane is used as the surrogate flammable vapor because it is representative of the paraffin hydrocarbons in the head space of gasoline containers (Harley et al, 2000 (3)), and it is significantly easier to control the concentration of n-butane in a hydrocarbon-air mixture than the concentrations of other (less volatile) vapors in gasoline of variable composition, or even of a standard designated gasoline composition. The test method needs to be applicable to most contemporary fuel and gasoline-alcohol based fuel formulations but will possibly not remain applicable if fuel formulations evolve toward volatile components with much smaller Maximum Experimental Safe Gaps (ref NFPA 497). When revising this standard consideration needs to be given to replacing butane with another hydrocarbon vapor, such as ethylene, with a smaller MESG.

9. Effectivity

9.1 *Effectivity*—The first version of this standard shall be effective one year after it has been published by ASTM.

10. Keywords

10.1 butane; chemical durability; child resistant closure; diesel; ethanol; flame mitigation device; flow resistance; fuel; fuel container; gasoline; kerosene; mechanical durability; portable fuel container (PFC)

APPENDIXES

(Nonmandatory Information)

X1. FLAME PROPAGATION TEST APPARATUS

INTRODUCTION

This appendix illustrates the apparatus used by WPI in their FMD experimentation and is provided for information only.

X1.1 Apparatus Description and Photographs

X1.1.1 The overall test apparatus used in the Worcester Polytechnic Institute (WPI) Combustion Laboratory is shown in Fig. X1.1. The polycarbonate tube is shown in Fig. X1.2, and the spark igniter is shown in Fig. X1.3.

X1.1.2 The bottom portion of the PFC to be ignition tested is cut off so that the FMD under test clears the mounting plate by 2 to 5 cm. The cut should be level so that the bottoms of the residual walls are at the same elevation, and the residual container sits flush on a flat horizontal surface.

X1.1.3 Using the cut off bottom of the PFC as a template, an outline of the bottom perimeter is drawn on a 3.2 mm ($\frac{1}{8}$ in.) thick plate of polymethyl methacrylate (PMMA) that will be the base plate for the modified PFC. A contour is drawn on the PMMA plate that extends 7.6 cm (3 in.) beyond the outline of the PFC bottom. The PMMA plate is cut along this contour.

X1.1.4 A 10 cm (4 in.) diameter hole is cut in the center of the PMMA plate. A panel which will blow out if internal ignition occurs, comprised of standard household aluminum foil with a thickness of approximately 0.016 mm, is formed over this opening. A second hole of 1.27 cm ($\frac{1}{2}$ in.) diameter is cut and tapped in the plate midway between edge of the 10 cm diameter hole and the PFC bottom perimeter.

X1.1.5 Using a silicone sealant, the top portion of the fuel container, containing the FMD to be ignition tested, is mounted and sealed to the PMMA base plate. At least 24 h is needed for the sealant to cure and set. The modified PFC with base plate is then attached to the frame of the test apparatus.

X1.1.6 The ignition tube is a transparent polycarbonate tube 120 ± 5 mm long, with internal diameter equal to 50 ± 5 mm (slightly larger than the open end of the pour spout) and is connected to the pour spout of the modified PFC using a tapered rubber stopper with central hole (See Fig. X1.2 for photo). The end of the ignition tube must be flush to the edge of the stopper. For spout off and separate filling opening ignition tests the internal diameter of the ignition tube is equal to the PFC opening diameter. Both setups are shown in 6.1.3.1.



FIG. X1.1 Modified PFC Mounted on Frame and Connected to Ignition Tube