



## Designation: ~~G8 – 96 (Reapproved 2010)~~ G8 – 96 (Reapproved 2019)

# Standard Test Methods for Cathodic Disbonding of Pipeline Coatings<sup>1</sup>

This standard is issued under the fixed designation G8; the number immediately following the designation indicates the year of original adoption or, in the case of revision, the year of last revision. A number in parentheses indicates the year of last reapproval. A superscript epsilon ( $\epsilon$ ) indicates an editorial change since the last revision or reapproval.

## 1. Scope

1.1 These test methods cover accelerated procedures for simultaneously determining comparative characteristics of insulating coating systems applied to steel pipe exterior for the purpose of preventing or mitigating corrosion that may occur in underground service where the pipe will be in contact with inland soils and may or may not receive cathodic protection. They are intended for use with samples of coated pipe taken from commercial production and are applicable to such samples when the coating is characterized by function as an electrical barrier.

1.2 This test method is intended for testing coatings submerged or immersed in the test solution at room temperature. When it is impractical to submerge or immerse the test specimen, Test Method **G95** may be considered where the test cell is cemented to the surface of the coated pipe specimen. If higher temperatures are required, see Test Method **G42**. If a specific test method is required with no options, see Test Method **G80**.

1.3 The values stated in SI units to 3 significant decimals are to be regarded as the standard. The values given in parentheses are for information only.

1.4 *This standard does not purport to address all of the safety concerns, if any, associated with its use. It is the responsibility of the user of this standard to establish appropriate safety, health, and environmental practices and determine the applicability of regulatory limitations prior to use.*

1.5 *This international standard was developed in accordance with internationally recognized principles on standardization established in the Decision on Principles for the Development of International Standards, Guides and Recommendations issued by the World Trade Organization Technical Barriers to Trade (TBT) Committee.*

## 2. Referenced Documents

### 2.1 ASTM Standards:<sup>2</sup>

**G12** Test Method for Nondestructive Measurement of Film Thickness of Pipeline Coatings on Steel (Withdrawn 2013)<sup>3</sup>

**G42** Test Method for Cathodic Disbonding of Pipeline Coatings Subjected to Elevated Temperatures

**G80** Test Method for Specific Cathodic Disbonding of Pipeline Coatings (Withdrawn 2013)<sup>3</sup>

**G95** Test Method for Cathodic Disbondment Test of Pipeline Coatings (Attached Cell Method)

## 3. Summary of Test Method

3.1 Both of the two test methods described subject the coating on the test specimen to electrical stress in a highly conductive, alkaline electrolyte. Electrical stress is obtained either by means of a sacrificial magnesium anode or from an impressed current system. The coating is perforated before starting the test.

3.1.1 In Method A, a magnesium anode is used with no electrical monitoring during the test period. The results are determined by physical examination after the test period is concluded.

3.1.2 In Method B, either a magnesium anode or an impressed current system may be used. Electrical instrumentation is provided for measuring the current in the cell circuit. The electrical potential is also measured, and upon conclusion of the test period, the test specimen is physically examined.

<sup>1</sup> These test methods are under the jurisdiction of ASTM Committee **D01** on Paint and Related Coatings, Materials, and Applications and are the direct responsibility of Subcommittee **D01.48** on Durability of Pipeline Coating and Linings.

Current edition approved ~~Dec. 1, 2010~~ June 1, 2019. Published ~~December 2010~~ June 2019. Originally approved in 1969. Last previous edition approved in ~~2003~~ 2010 as **G8 – 96 (2003)** (2010), <sup>1</sup>; DOI: ~~10.1520/G0008-96R10~~ 10.1520/G0008-96R19.

<sup>2</sup> For referenced ASTM standards, visit the ASTM website, [www.astm.org](http://www.astm.org), or contact ASTM Customer Service at [service@astm.org](mailto:service@astm.org). For *Annual Book of ASTM Standards* volume information, refer to the standard's Document Summary page on the ASTM website.

<sup>3</sup> The last approved version of this historical standard is referenced on [www.astm.org](http://www.astm.org).

3.1.3 In both test methods physical examination is conducted by comparing the extent of loosened or disbonded coating at the perforations in the immersed area with extent of loosened or disbonded coating at a new test hole in the coating made in an area that was not immersed.

#### 4. Significance and Use

4.1 Breaks or holidays in pipe coatings may expose the pipe to possible corrosion, since after a pipe has been installed underground, the surrounding earth will be more or less moisture-bearing and it constitutes an effective electrolyte. Damage to pipe coating is almost unavoidable during transportation and construction. Normal soil potentials as well as applied cathodic protection potentials may cause loosening of the coating, beginning at holiday edges, in some cases increasing the apparent size of the holiday. Holidays may also be caused by such potentials. While apparently loosened coating and cathodic holidays may not result in corrosion, this test provides accelerated conditions for loosening to occur and therefore gives a measure of resistance of coatings to this type of action.

4.2 The effects of the test may be evaluated by either physical examination or monitoring the current drawn by the test specimen and both of these two. Usually there is no correlation between the two methods of evaluation but both methods are significant. Physical examination consists of assessing the effective contact of the coating with the metal surface in terms of observed differences in the relative adhesive bond. It is usually found that the electrically stressed area propagates from the holiday to a boundary where the loosened coating leaves off for the more effective contact or bond attributed to an original condition throughout the specimen before electrical stressing was applied. Assumptions associated with test results include the following:

4.2.1 Attempting to loosen or disbond the coating at a new test hole made in the coating in an area that was not immersed represents maximum adhesion or bond as measured by the lifting technique used, and that the same lifting technique can be used at a test hole that was immersed thereby providing a means of comparing relative resistance to lifting.

4.2.2 Any relatively lesser bonded area at the immersed test holes in the coating was caused by electrical stressing and was not attributable to an anomaly in the application process. Ability to resist disbondment is a desired quality on a comparative basis, but disbondment per se in this test is not necessarily an adverse indication. The virtue of this test is that all dielectric type coatings now in common use will disbond to some degree thus providing a means of comparing one coating with another. Bond strength is more important for proper functioning of some coatings than others and the same measured disbondment for two different coating systems may not represent equivalent loss of corrosion protection.

4.2.3 The amount of current in the test cell is a relative indicator of the extent of areas requiring protection against corrosion; however, the current density appearing in this test is much greater than that usually required for cathodic protection in natural, inland soil environments.

#### 5. Apparatus

##### 5.1 Apparatus for Both Methods:

5.1.1 *Test Vessel*—A nonconducting material shall be used for the vessel or as a lining in a metallic vessel. Dimensions of the vessel shall permit the following requirements:

- 5.1.1.1 Test specimens shall be suspended vertically in the vessel with at least 25.4-mm (1-in.) clearance from the bottom.
- 5.1.1.2 Each test specimen shall be separated from the other specimens, from the anodes and from the walls of the test vessel by at least 38.1 mm (1.500 in.).
- 5.1.1.3 Depth of electrolyte shall permit the test length of the specimen to be immersed as required in 7.4.
- 5.1.1.4 If electrical monitoring is to be performed as required in Method B, the reference electrode may be placed anywhere in the vessel, provided it is separated from the specimen and from the anode by not less than 38.1 mm (1.500 in.).

5.1.2 *Magnesium Anode*—The anode shall be made of a magnesium alloy having a solution potential of  $-1.45$  to  $-1.55$  V with respect to a  $\text{CuCuSO}_4$  reference electrode in the electrolyte given in 6.1. It shall have a surface area not less than one third that of the total specimen area exposed to electrolyte (outside area exposed only). The anode shall be provided with a factory-sealed, 4107-cmil (14-gage Awg), minimum, insulated copper wire. Anodes without a factory seal may be used if the magnesium extends above the cover.

5.1.3 *Connectors*—Wiring from anode to test specimen shall be 4107-cmil (14-gage Awg), minimum, insulated copper. Attachment to the test specimen shall be by soldering, brazing, or bolting to the nonimmersed end, and the place of attachment shall be coated with an insulating material. A junction in the connecting wire is permitted, provided that it is made by means of a bolted pair of terminal lugs soldered or mechanically crimped to clean wire ends.

5.1.4 *Holiday Tools*—Holidays shall be made with conventional drills of the required diameter. For use in preparing small-diameter pipe specimens such as 19.05 mm (0.750 in.) nominal diameter pipe, the use of a drill modified by substantially grinding away the sharp cone point has been found effective in preventing perforation of the metal wall of the pipe. A sharp-pointed knife with a safe handle is required for use in making physical examinations.

5.1.5 *High-Resistance Voltmeter*, for direct current, having an internal resistance of not less than 10 M $\Omega$  and having a range from 0.01 to 5 V for measuring potential to the reference electrode.

5.1.6 *Reference Electrode*, saturated  $\text{CuCuSO}_4$  of conventional glass or plastic tube with porous plug construction, preferably not over 19.05 mm (0.750 in.) in diameter, having a potential of  $-0.316$  V with respect to the standard hydrogen electrode. A calomel electrode may be used, but measurements made with it shall be converted to the  $\text{CuCuSO}_4$  reference for reporting by adding  $-0.072$  V to the observed reading.

5.1.7 *Thickness Gage*, for measuring coating thickness in accordance with Test Method G12.

5.1.8 *Thermometer*, for measuring electrolyte temperature, general lab type,  $1^\circ$  subdivisions, 76.2 mm (3 in.) immersion.

5.2 *Additional Apparatus for Method B*:

5.2.1 *High-Resistance Voltmeter*, for direct current, having an internal resistance of not less than  $10\text{ M}\Omega$  and capable of measuring as low as  $10\ \mu\text{V}$  potential drop across a shunt in the test cell circuit.

5.2.2 *Precision Wire-Wound Resistor*,  $1\text{-}\Omega \pm 1\%$ , 1-W (minimum), to be used in the test cell circuit as a shunt for current.

5.2.3 *Volt-Ohm-Meter*, for initial testing of apparent coating resistance.

5.2.4 *Metallic Electrode*, used temporarily with the volt-ohm-meter to determine apparent initial holiday status of the test specimen.

5.2.5 *Additional Connecting Wires*, 4107-cmil (14-gage Awg), minimum, insulated copper.

5.2.6 *Brass Studs*, used at a terminal board, together with alligator clips or knife switches, for making and breaking circuits. Alligator clips shall not be used to connect to electrodes or specimens at the top location of test cells.

5.2.7 *Zero-Resistance Ammeter*, capable of measuring direct current as low as  $10\ \mu\text{A}$  may be used in the alternative method given in 9.1.3 and substituted for the apparatus described in 5.2.1 and 5.2.2.

5.2.8 *Direct-Current Rectifier*, capable of supplying constant voltage at a voltage of  $1.50 \pm 0.01$  V, as measured between the specimen and reference electrode.

5.2.9 *Impressed Current Anode*, shall be of the nonconsumable type provided with a factory sealed, insulated copper wire.<sup>4</sup>

5.2.10 *Voltage Divider*, 100- $\Omega$ , 25-W rheostat, to be used if more than one specimen is to be tested as shown in Fig. 1.

## 6. Reagent and Materials

6.1 The electrolyte shall consist of potable tap water with the addition of 1 mass % of each of the following technical-grade salts, calculated on an anhydrous basis: sodium chloride, sodium sulfate, and sodium carbonate. Use freshly prepared solution for each test.

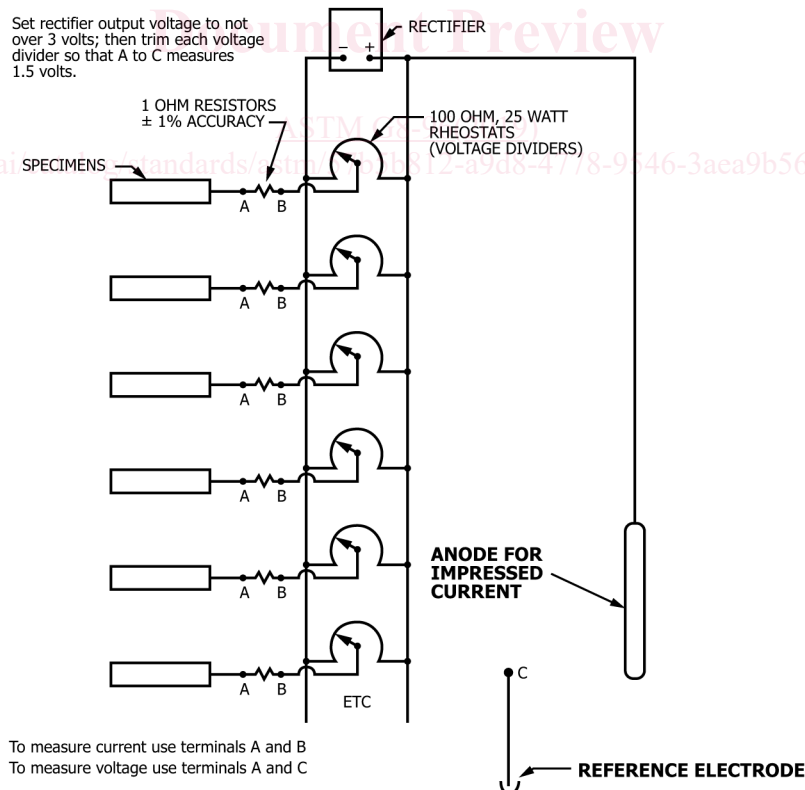

FIG. 1 Modification of Method B (Fig. 5) Using Impressed Current to Test More than One Specimen

<sup>4</sup> Durion, a material found suitable for this purpose is available from Durion Co., Inc., Dayton OH.

6.2 Materials for sealing the ends of coated pipe specimens may consist of bituminous products, wax, epoxy, or other materials, including molded elastomeric or plastic end caps.

6.3 Plywood or plastic material has been found suitable for the construction of test vessel covers and for the support through apertures of test specimens and electrodes. Wood dowels introduced through holes in the top ends of test specimens have been found suitable for suspending test specimens from the vessel cover.

**7. Test Specimen**

7.1 The test specimen shall be a representative piece of production-coated pipe. One end shall be plugged or capped, and sealed.

7.2 One or three holidays shall be made in each specimen. Three holidays are recommended. Recommended dimensions are given in Fig. 2. A specimen with one holiday shall have it drilled in the middle of the immersed length. If three holidays are used, they shall be drilled 120° apart with one in the center and the other two at locations one fourth the distance from top and bottom of the immersed test length. Each holiday shall be drilled so that the angular cone point of the drill will fully enter the steel where the cylindrical portion of the drill meets the steel surface. The drill diameter shall be not less than three times the coating thickness, but it shall never be smaller than 6.35 mm (0.250 in.) in diameter. The steel wall of the pipe shall not be perforated. With small-diameter pipes, where there is danger of perforating the pipe, the holiday shall be started with a standard 60° cone point and finished with a drill that has had a substantial portion of the cone point ground away.

NOTE 1—Before making the holiday, see 8.1.

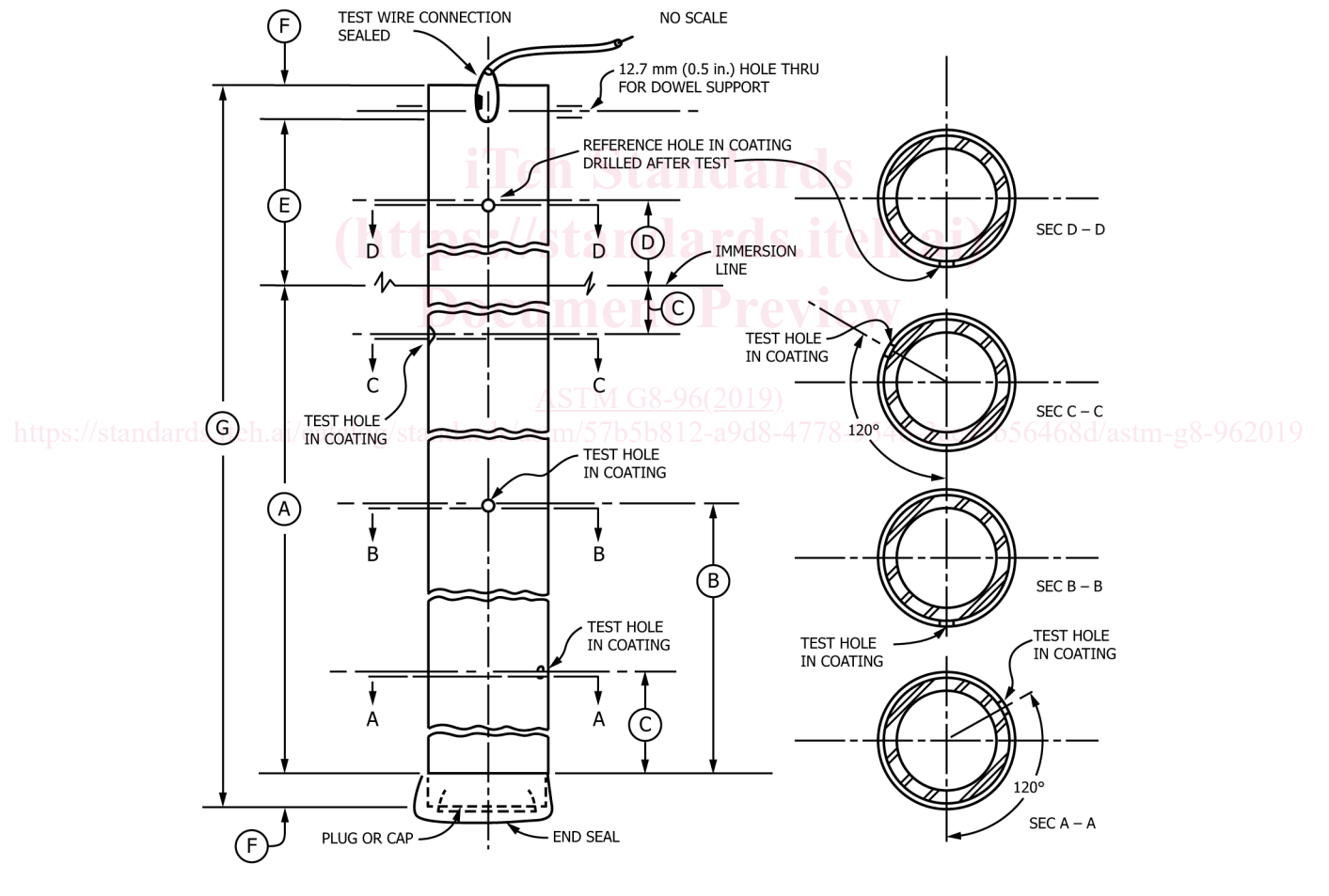

FIG. 2 Recommended Dimensions for Specimen

7.3 The end of the pipe which will protrude above the immersion line shall be provided with suitable supporting means and a separate wire connection for electrical purposes, soldered, brazed, or bolted to the pipe. The protruding end, including hanger and wire connections, shall be protected and sealed with an insulating coating material.

7.4 The specimen test area shall consist of the area between the edge of the bottom end seal and the immersion line. The bottom end seal area shall not be considered part of the area tested. Any suitable diameter and specimen length of pipe may be used, but the immersed area shall be not less than 23 227 mm<sup>2</sup> (36 in.<sup>2</sup>). An area of 92 900 mm<sup>2</sup> (1 ft<sup>2</sup>) has been found preferable when convenient.

## 8. Specimen Preparation

8.1 Before making artificial holidays, verify the continuity of the coating and the effectiveness of the end-cap seal as follows:

8.1.1 Immerse the test specimen and a metallic electrode in the electrolyte. Connect one terminal of the multimeter to the test specimen and the other terminal to the metallic electrode. Measure the apparent resistance in ohms, making two determinations: one with the specimen connected to the positive terminal of the multimeter; and one with the specimen connected to the negative terminal.

8.1.2 Disconnect the specimen from the multimeter but leave it immersed for 15 min. Then, measure the resistance again as in 8.1.1.

8.1.3 A significant decrease in either resistance reading after 15 min will indicate a flaw in the coating or end-cap seal. Reject the specimen if the flaw is identified in the coating. If the flaw is in the end-cap seal, it may be repaired and the resistance remeasured as in 8.1.1 and 8.1.2.

8.1.4 The lowest resistance after 15 min of immersion shall be not less than 1000 MΩ but a stable reading below 1000 MΩ may not indicate a flaw and the specimen may be used for test. All resistance measurements shall be reported in the results.

8.2 Record initial holiday diameter(s).

8.3 Measure and record the minimum and maximum coating thickness in accordance with Test Method G12, and the thickness where each holiday is made.

## 9. Procedure for Method A

9.1 Immerse the test specimen in the electrolyte and connect it to the anode as shown in Fig. 3. Position the middle or single holiday so that it faces away from the anode. Space the anode with respect to test specimens as described in 5.1.1. Mark the correct immersion level of the test specimen with a grease pencil and maintain by daily additions of potable water as required. Perform the test at electrolyte temperature of 21 to 25°C (70 to 77°F).

9.1.1 In order to ascertain that the test cell is functioning, measure the potential between test specimen and a reference electrode immediately after starting the test and immediately before terminating it. Use temporary connections and instrumentation, as shown in Fig. 3. The potential measured shall be  $-1.45$  V to  $-1.55$  V with respect to a CuCuSO<sub>4</sub> reference electrode. Use the instrument described in 5.1.5. [atalog/standards/astm/57b5b812-a9d8-4778-9546-3aea9b56468d/astm-g8-962019](https://www.astm.org/standards/astm/57b5b812-a9d8-4778-9546-3aea9b56468d/astm-g8-962019)

9.2 Duration of the test period shall be 30 days. Optionally, other test periods such as 60 or 90 days may be used.

9.3 An examination shall be performed immediately upon termination of the test period as follows:

9.3.1 At the end of the test period, disassemble the cell and rinse the test area with warm tap water. Immediately wipe the sample dry and visually examine the entire test area for any evidence of unintentional holidays and loosening of coating at the edge of all holidays, including the intentional holiday, and record coating condition, for example, color, blisters, cracking, crazing, adhering deposits, etc.

9.3.2 Drill a new reference holiday in the coating in an area that was not immersed. Follow the same drilling procedure as described in 7.2.

9.3.3 Make radial 45° cuts through the coating intersecting at the center of both the intentional holiday and the reference holiday with a sharp, thin-bladed knife. Take care to ensure that coating is cut completely through to the steel substrate.

9.3.4 Attempt to lift the coating at both the reference holiday and the intentional holiday with the point of a sharp, thin-bladed knife. Use the bond at the reference holiday as a reference for judging the quality of the bond at the intentional holiday. Measure and record the total area of disbonded coating at the intentional holiday.

NOTE 2—The use of a transparent film having a grid laid out in small squares such as 2.54 mm (0.1 in.) on a side has been found useful. The film is placed against the unsealed area and the boundary of the unsealed area traced on the grid. The area is then obtained by counting the squares within the bonded area.

## 10. Procedure for Method B

10.1 In addition to the procedure given in Section 9, monitor the progress of the test electrically in accordance with the schedule given in 10.2 as follows:

10.1.1 If a magnesium anode is to be used, install the test assembly shown in Fig. 4. If impressed current for a single specimen is to be used, install the test assembly shown in Fig. 5; if more than one specimen is to be tested, use the modification shown in Fig. 1.



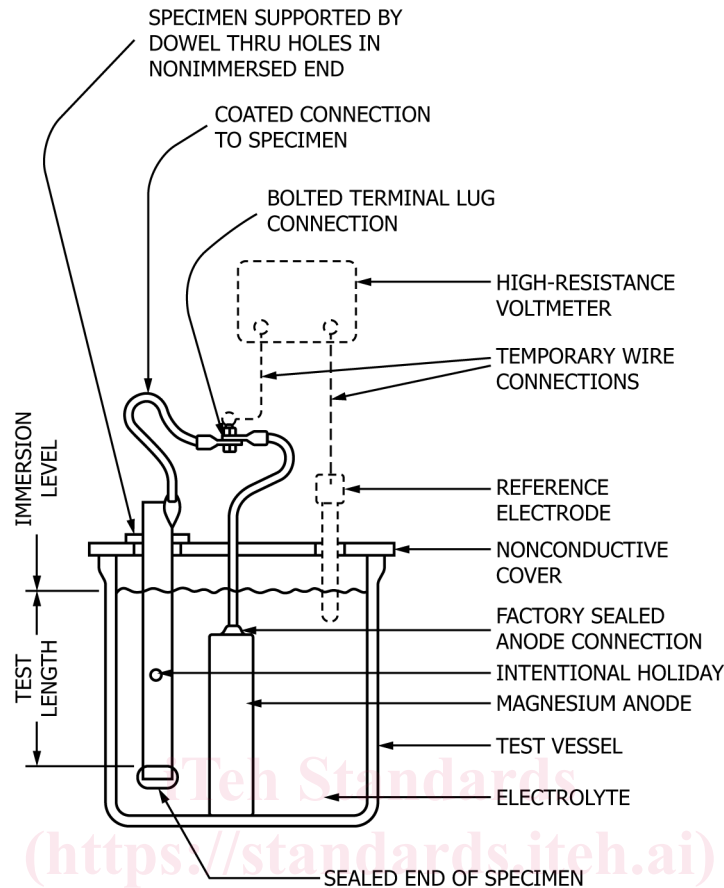

NOTE 1—Test hole made in non-immersed area after testing not shown (see Fig. 2).

FIG. 3 Test Assembly for Method A Using a Magnesium Anode

ASTM G8-96(2019)

<https://standards.iteh.ai/catalog/standards/astm/57b5b812-a9d8-4778-9546-3aea9b56468d/astm-g8-962019>

10.1.2 Measure  $E_2$ , the stress potential in volts between test specimen and reference electrode, with a multimeter without disconnecting the anode from the test specimen. Use the instrument described in 5.1.5. If a  $\text{CuCuSO}_4$  electrode is used, immerse only temporarily.

10.1.3 Measure  $I_1$ , the current demand in amperes, by determining the potential drop across the 1- $\Omega$  resistor permanently installed in the test cell circuit with the multimeter described in 5.2.1. The voltage reading will be numerically equal to amperes.

NOTE 3—An alternative method of measuring current demand may be used by means of the instrument described in 5.2.4. In this method, the wire connection between test specimen and anode is temporarily broken and a zero-resistance ammeter temporarily interposed between the specimen and the anode. Reconnect the specimen to the anode with the connector wire as soon as this measurement is completed.

10.1.4 Measure  $E_1$ , the polarized potential, in volts. Do this with the multimeter described in 5.1.5 connected between the test specimen and the reference electrode as follows:

10.1.4.1 Disconnect the anode from the test specimen while closely observing the multimeter. As the instrument pointer falls, it will dwell significantly at the polarized value before receding further. The dwell point is  $E_1$ . If a  $\text{CuCuSO}_4$  electrode is used, immerse only temporarily.

10.2 Electrical Monitoring Schedule:

10.2.1 Electrical measurements at the start of the test are defined as the average of measurements taken on the second and third days after immersion. Measurements may be taken on the day of immersion in order to ascertain functioning of the test cell, but such measurements are not to be used in calculating the change in characteristics from start to target dates in the conduct of the test.

10.2.2 Make electrical measurements at the start of a test and on a target date after 30 days. The test may be continued for 60 or 90-day targets with intermediate and corresponding electrical measurements.

10.2.3 Take electrical measurements for intermediate target dates and for the terminal date on 2 successive days prior to and including the target date. The average of readings taken on the 2 days is defined as the target date measurement.

10.2.4 Rectifier current shall be continuous. Any interruptions must be reported.