



Designation: **D4894 – 15 D4894 – 19**

Standard Specification for Polytetrafluoroethylene (PTFE) Granular Molding and Ram Extrusion Materials ¹

This standard is issued under the fixed designation D4894; the number immediately following the designation indicates the year of original adoption or, in the case of revision, the year of last revision. A number in parentheses indicates the year of last reapproval. A superscript epsilon (ϵ) indicates an editorial change since the last revision or reapproval.

1. Scope*

1.1 This specification covers granular resins and test methods for polytetrafluoroethylene (PTFE) that have never been preformed or molded and are normally processed by methods similar to those used in powder metallurgy or ceramics, or by special extrusion processes. These PTFE resins are homopolymers of tetrafluoroethylene, or, in some cases, modified homopolymers containing not more than one percent by weight of other fluoromonomers. The usual methods of processing thermoplastics generally are not applicable to these materials because of their viscoelastic properties at processing temperatures. The materials included herein do not include mixtures of PTFE resin with additives such as colorants, fillers or plasticizers; nor do they include reprocessed or reground resin or any fabricated articles. The methods and properties included are those required to identify the various types of resins. Additional procedures are provided in the Appendix for further characterization of the resins.

1.2 The values stated in SI units as detailed in **IEEE/ASTM SI-10** are to be regarded as the standard, and the practices of **IEEE/ASTM SI-10** are incorporated herein.

1.3 The following precautionary caveat pertains only to the Specimen Preparation section, Section 9, and the Test Methods section, Section 10, of this specification: *This specification does not purport to address all of the safety concerns, if any, associated with its use. It is the responsibility of the user of this standard to establish appropriate safety and health practices and determine the applicability of regulatory limitations prior to use.* See Notes 3 and 9 for specific cautionary statements.

NOTE 1—Information in this specification is technically equivalent to related information in ISO 12086-1 and ISO 12086-2.

1.4 *This international standard was developed in accordance with internationally recognized principles on standardization established in the Decision on Principles for the Development of International Standards, Guides and Recommendations issued by the World Trade Organization Technical Barriers to Trade (TBT) Committee.*

2. Referenced Documents

- 2.1 *ASTM Standards:*²
- D618 Practice for Conditioning Plastics for Testing
 - D792 Test Methods for Density and Specific Gravity (Relative Density) of Plastics by Displacement
 - D883 Terminology Relating to Plastics
 - D1708 Test Method for Tensile Properties of Plastics by Use of Microtensile Specimens
 - D1895 Test Methods for Apparent Density, Bulk Factor, and Pourability of Plastic Materials
 - D3295 Specification for PTFE Tubing, Miniature Beading and Spiral Cut Tubing
 - D3892 Practice for Packaging/Packing of Plastics
 - D4441 Specification for Aqueous Dispersions of Polytetrafluoroethylene
 - D4591 Test Method for Determining Temperatures and Heats of Transitions of Fluoropolymers by Differential Scanning Calorimetry
 - D4745 Classification System and Basis for Specification for Filled Polytetrafluoroethylene (PTFE) Molding and Extrusion Materials Using ASTM Methods
 - D4895 Specification for Polytetrafluoroethylene (PTFE) Resin Produced From Dispersion
 - E11 Specification for Woven Wire Test Sieve Cloth and Test Sieves

¹ This specification is under the jurisdiction of ASTM Committee D20 on Plastics and is the direct responsibility of Subcommittee D20.15 on Thermoplastic Materials. Current edition approved May 1, 2015; May 1, 2019. Published June 2015; June 2019. Originally approved in 1989. Last previous edition approved in 2012 as D4894 - 07; D4894 - 15; (2012). DOI: 10.1520/D4894-15; 10.1520/D4894-19.

² For referenced ASTM standards, visit the ASTM website, www.astm.org, or contact ASTM Customer Service at service@astm.org. For *Annual Book of ASTM Standards* volume information, refer to the standard's Document Summary page on the ASTM website.

*A Summary of Changes section appears at the end of this standard

E177 Practice for Use of the Terms Precision and Bias in ASTM Test Methods

IEEE/ASTM SI-10 Standard for Use of the International System of Units (SI): The Modern Metric System

2.2 ISO Standards:³

ISO 12086-1 Plastics—Fluoropolymer Dispersions and Moulding and Extrusion Materials—Part 1: Designation System and Basis for Specification

ISO 12086-2 Test Methods for Fluoropolymers

3. Terminology

3.1 Definitions:

3.1.1 The terminology given in Terminology D883 is applicable to this specification.

3.2 Descriptions of Terms Specific to This Standard:

3.2.1 *bulk density*—the mass (in grams) per ~~liter~~ liter of resin measured under the conditions of the test.

3.2.2 *extended specific gravity (ESG)*—the specific gravity of a specimen of PTFE material molded as described in this specification and sintered (g.v.) for an extended period of time, compared to the sintering time for the measurement of standard specific gravity (SSG), using the appropriate sintering schedule given in this specification.

3.2.3 *lot, n*—one production run or a uniform blend of two or more production runs.

3.2.4 *preforming*—compacting powdered PTFE material under pressure in a mold to produce a solid object, called a preform, that is capable of being handled. Molding and compaction are terms used interchangeably with preforming for PTFE.

3.2.5 *reground resin*—that produced by grinding PTFE material that has been preformed but has never been sintered.

3.2.6 *reprocessed resin*—that produced by grinding PTFE material that has been both preformed and sintered.

3.2.7 *sintering*—as it applies to PTFE, a thermal treatment during which the PTFE is melted and recrystallized by cooling with coalescence occurring during the treatment.

3.2.8 *skiving*—a machining operation during which a continuous film of PTFE material is peeled from the lateral surface of a cylindrical sintered molding.

3.2.9 *standard specific gravity (SSG)*—the specific gravity of a specimen of PTFE material molded as described in this specification and sintered using the appropriate sintering schedule given in this specification.

3.2.10 *thermal instability index (TII)*—a measure of the decrease in molecular weight of PTFE material which has been heated for a prolonged period of time.

4. Classification

4.1 This specification covers the following six types of PTFE generally used for compression molding or ram extrusion, or both:

4.1.1 *Type I*—Resin used for general-purpose molding and ram extrusion.

4.1.2 *Type II*—Finely divided resin with an average particle size less than 100 micrometres.

4.1.3 *Type III*—Modified resins, either finely divided or free-flowing, typically used in applications requiring improved resistance to creep and stress-relaxation in end-use.

4.1.4 *Type IV*—Free-flowing resins. Generally made by treatment of finely divided resin to produce free-flowing agglomerates.

4.1.5 *Type V*—Presintered. Resin that has been treated thermally at or above the melting point of the resin at atmospheric pressure without having been previously preformed.

4.1.6 *Type VI*—Resin, not presintered, but for ram extrusion only.

NOTE 2—See Tables 1 and 2 for division of Types by Grades, and footnotes to Tables 1 and 2 (and Table X2.1 in Appendix X2.) for former classifications.

4.2 A line callout system is used to specify materials in this standard. The system uses predefined cells to refer to specific aspects of this specification, illustrated as follows:

Standard Number Block	:	Type	:	Grade	:	Class	:	Special notes
Example: ASTM D4894 – 04	:	III	:	2	:		:	

For this example, the line callout would be ASTM D4894 – 04, III2, and would specify a granular polytetrafluoroethylene that has all of the properties listed for that Type and Grade in the appropriate specified properties, Tables, or both, in this specification. In this case there is no Class item so the cell position for class is left blank. A comma is used as the separator between Standard

³ Available from American National Standards Institute (ANSI), 25 W. 43rd St., 4th Floor, New York, NY 10036, <http://www.ansi.org>.

TABLE 1 Detail Requirements for Tests on Resins^A

Type	Grade	Bulk Density, g/L	Particle Size, Average Diameter, μm	Water Content, max, %	Melting Peak Temperature	
					Initial °C	Second °C
I	1	700 ± 100	500 ± 150	0.04	^A	327 ± 10
	2	675 ± 50	375 ± 75	0.04	^A	327 ± 10
II	<100	0.04	^A	327 ± 10
III	1	400 ± 125	<100	0.04	^A	327 ± 10
	2	850 ± 100	500 ± 150	0.04	^A	327 ± 10
IV	3	400 ± 125	<100	0.04	^A	327 ± 10
	1	650 ± 150	550 ± 225	0.04	^A	327 ± 10
	2	>800	...	0.04	^A	327 ± 10
V	3	580 ± 80	200 ± 75	0.04	^A	327 ± 10
	...	635 ± 100	500 ± 250	0.04	327 ± 10	327 ± 10
VI	...	650 ± 150	800 ± 250	0.04	^A	327 ± 10

^A >5°C above the second melting peak temperature.

TABLE 2 Detail Requirements for Tests on Molded Specimens

Type	Grade	Thermal Instability Index, max	Standard Specific Gravity		Tensile Strength, min		Elongation at break min %
			min	max	MPa	psi	
I	1	50	2.13	2.18	13.8	2000	140
	2	50	2.13	2.18	17.2	2500	200
II	...	50	2.13	2.19	27.6	4000	300
III	1	50	2.14	2.22	28.0	4060	450
	2	50	2.14	2.18	20.7	3000	300
IV	3	50	2.14	2.18	28.0	4000	300
	1	50	2.13	2.19	25.5	3700	275
	2	50	2.13	2.19	27.6	4000	300
V	3	50	2.15	2.18	27.6	4000	200
	...	NA ^A	NA ^A	NA ^A	NA ^A	NA ^A	NA ^A
VI ^B	...	NA ^A	NA ^A	NA ^A	NA ^A	NA ^A	NA ^A

^A NA: Not Applicable by molding techniques included in this specification.

^B Extrusions of this resin show different degrees of clarity from the others.

Number and Type. Separators are not needed between Type, Grade, and Class.⁴ Provision for Special Notes is included so that other information will be provided when required. An example would be in Specification **D3295** where dimensions and tolerances are specified for each AWG size within Type and Class. When Special Notes are used, they shall be preceded by a comma.

5. Mechanical Properties

5.1 The resins covered by this specification shall conform to the requirements prescribed in **Tables 1 and 2** when tested by the procedures specified herein. **Table 1** lists tests to be carried out on resins. **Table 2** lists tests requiring specimens molded as described in Section 9.

6. Other Requirements

6.1 The resin shall be uniform and shall contain no additives or foreign material.

6.2 The color of the material as shipped by the seller shall be white.

7. Sampling

7.1 Sampling shall be statistically adequate to satisfy the requirements of **11.4**

8. Number of Tests

8.1 Lot inspection shall include tests for bulk density, particle size and standard specific gravity. Periodic tests shall consist of all the tests specified in **Tables 1 and 2** and shall be made at least one per year.

8.2 The tests listed in **Tables 1 and 2**, as they apply, are sufficient to establish conformity of a material to this specification. One set of tests specimens as prescribed in Section 7 shall be considered sufficient for testing each sample. The average of the results for the specimens tested shall conform to the requirements of this specification.

9. Specimen Preparation

9.1 *Test Disks:*

⁴ See the *Form and Style for ASTM Standards* manual available from ASTM Headquarters.

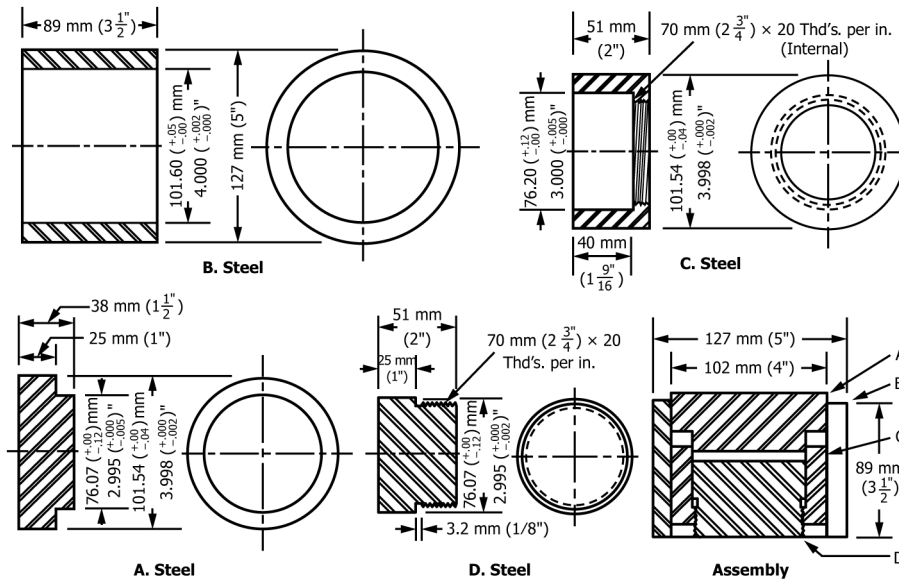

FIG. 1 Assembly and Details of Die for Molding Test Specimens

9.1.1 Use the die shown in Fig. 1 for the molding of test disks. The test resin shall be near ambient temperature prior to molding (Note 5). **Warning**—PTFE can evolve small quantities of gaseous products when heated above 204°C (400°F). Some of these gases are harmful. Consequently, exhaust ventilation must be used whenever the resins are heated above this temperature, as they are during the sintering operations that are a part of this specification. Since the temperature of burning tobacco exceeds 204°C (400°F), those working with PTFE resins should ensure that tobacco is not contaminated.

9.1.2 Screen 14.5 g (for tensile properties) or 7.25 g (for electrical properties discussed in Appendix X1.7) of PTFE resin through a No. 10 hand sieve into the die. Adjust the lower plug height to allow the resin in the die can be leveled by drawing a straightedge in contact with the top of the die across the top of the die cavity. Insert the die in a suitable hydraulic press and apply pressure gradually (Note 3) until a total of 34.5 MPa (5000 psi) is attained. Hold this pressure for 3 min. Remove the disk identification on the disk at this time.

NOTE 3—As a guide, increasing the pressure at a rate of 3.45 MPa (500 psi)/min is suggested until the desired maximum pressure is attained.

9.1.3 Sinter the preforms in accordance with Table 3 (Note 4).

9.1.3.1 Use Procedure B for Types I, II and IV and Procedure C for Type III.

NOTE 4—Although the rate of heating application is not critical, the cooling cycle is most important and the conditions cited in these procedures must be followed very closely. If they are not followed, the crystallinity of the disks and the resulting physical properties will be markedly changed. Therefore, the use of a programmed oven is recommended for the most precise sintering cycle control so that the hood window will be left down during the entire sintering procedure, the latter being an important safety consideration.

9.2 Test Specimens for Standard Specific Gravity (SSG) and Extended Specific Gravity (ESG):

9.2.1 A cylindrical preforming die, 28.6 mm (1 1/8 in.) internal diameter by at least 76.2 mm (3 in.) deep, is used to prepare the preforms. End plug clearances shall be sufficient to ensure escape of air during pressing. The test resin shall be near ambient temperature prior to molding (Note 5).

NOTE 5—For maximum precision, the weighing and preforming operations shall be carried out at 23 ± 2°C (73.4 ± 3.6°F) (the “near ambient” temperature referred to herein). These operations shall not be performed at temperatures below 21°C (70°F) due to the crystalline transition that occurs in PTFE in this temperature region which leads to possible cracks in sintered specimens and differences in specimen density (as well as changes in other physical properties). Problems caused by the effects of temperature on the specific gravity or density of PTFE will be minimized when the measurement is made using immersion procedures if a sensitive thermometer (for example, one reading ± 0.1°C) is used in the liquid and the temperature is adjusted to be at least 22°C.

9.2.2 Weigh out 12.0 ± 0.1 g of resin and place it in the die. Screen non-free-flowing resins through a No. 10 sieve. Break up compacted resins by hand-shaking cold resin in a half-filled sealed glass container. Condition the resin in the sealed glass container in a freezer or dry-ice chest. After breaking up resin lumps, allow the sealed container to equilibrate to near ambient temperature. Then screen and weigh the 12.0 ± 0.1-g sample. Insert the die in a suitable hydraulic press and apply pressure gradually (Note 3) until a pressure of 34.5 MPa (5000 psi) is attained. Hold this pressure for 2 min. Remove the preform from the die. Write the sample identification number using an appropriate marker that will not effect the PTFE during sintering on the preform at this time.

9.2.3 Sinter the preforms in accordance with Table 3 (Note 4).

9.2.3.1 For SSG specimens use Procedure B for Types I, II and IV and Procedure C for Type III.

9.2.3.2 For ESG specimens use Procedure F for Types I, II and IV and Procedure G for Type III.

TABLE 3 Sintering Procedures

	B	C	D	E	F	G	H	I
Initial temperature, °C (°F)	290 (554)	290 (554)	238 (460)	238 (460)	290 (554)	238 (460)	238 (460)	238 (460)
Rate of heating, °C/h (°F/h)	120 ± 10 (216 ± 18)	120 ± 10 (216 ± 18)	60 ± 5 (108 ± 9)	60 ± 5 (108 ± 9)	120 ± 10 (216 ± 18)	60 ± 5 (108 ± 9)	60 ± 5 (108 ± 9)	60 ± 5 (108 ± 9)
Hold temperature, °C (°F)	380 ± 6 (716 ± 10)	357 ± 8 (675 ± 15)	371 ± 6 (700 ± 10)	360 ± 6 (685 ± 10)	380 ± 6 (716 ± 10)	357 ± 8 (675 ± 5)	380 ± 6 (716 ± 10)	371 ± 6 (700 ± 10)
Hold time, min	30 + 2, -0	30 + 2, -0	240 ± 15	240 ± 15	360 ± 5	240 ± 15	960 ± 15	120 ± 5
Cooling rate, °C/h (°F/h)	60 ± 5 (108 ± 9)	60 ± 5 (108 ± 9)	60 ± 5 (108 ± 9)	60 ± 5 (108 ± 9)	60 ± 5 (108 ± 9)	60 ± 5 (108 ± 9)	60 ± 5 (108 ± 9)	60 ± 5 (108 ± 9)
Final or second hold temperature, °C (°F)	294 ± 6 (561 ± 10)	294 ± 6 (561 ± 10)	238 ± 6 (460 ± 10)	238 ± 6 (460 ± 10)	294 ± 6 (561 ± 10)	238 ± 6 (460 ± 10)	238 ± 6 (460 ± 10)	238 ± 6 (460 ± 10)
Second hold time, min	24 + 0.5, -0	24 + 0.5, -0	NA ^A	NA ^A	24 + 0.5, -0	NA ^A	NA ^A	NA ^A
Period to room temperature, min, h	½	½	6	6	½	6	6	6

^A NA, Not applicable.

NOTE 6—Improved precision in SSG and ESG test results has been obtained with the use of an upright, cylindrical oven and an aluminum sintering rack. The cylindrical oven has an inside diameter of 140 mm (5.5 in.) and an inside depth of 203 mm (8 in.) plus additional depth to accommodate a 50.8-mm (2-in.) thick cover, and is equipped with suitable heaters and controllers to sinter specimens in accordance with the Procedures in Table 3. The rack, as shown in Fig. 2, allows preforms to be placed symmetrically in the center region of the oven. Place six preforms on each of the middle oven rack shelves (if six or fewer preforms are to be sintered, place them on the middle rack, filling in with “dummies” as needed). Place “dummies” on the top and bottom shelves. Specimens must be spaced evenly in a circle on each shelf, with none of them touching. An oven load must be no less than 18 pieces including “dummies.” “Dummies” are defined as normal 12-g specimens that have previously been through the sintering cycle. “Dummies” must only be used for an additional two or three thermal cycles, due to eventual loss of thermal stability and physical form.

9.2.4 Remove all flash from each specimen so that no air bubbles will cling to the edges when the specimen is immersed in the solution for weighing during the standard specific gravity and thermal instability index tests. It is recommended for this section and during testing that cotton gloves be worn while handling test specimens.

9.3 Test Billets:

9.3.1 Use test specimens cut or skived from billets may be used as alternatives to the test disks described in 9.1 and 9.2 for Types I, II, III and IV resins.

9.3.2 Mold test billets in a mold similar to Fig. 3, having an inside diameter of 57 mm (2.25 in.) and of sufficient height to contain the resin sample. Plug clearance shall be sufficient to ensure escape of air during pressing. A 254-mm (10-in.) mold cavity fill depth will produce a billet approximately 76 mm (3 in.) long from a resin charge of 400 ± 50 g. Vary the billet length in accordance with the testing to be done. The test resin shall be near ambient temperature prior to molding (Note 4).

9.3.2.1 Adjust the lower plug position using a support ring to position the mold shell so that the resin level will not come within 13 mm (0.5 in.) of the top of the mold cavity. Add the resin to the mold, insert the top plug, and apply hand pressure. Remove the support ring, and place the mold in a hydraulic press.

9.3.2.2 Apply an initial pressure of 3.45 MPa (500 psi) ± 10 % and hold for 1 to 2 min. Increase the pressure smoothly to the final preforming pressure in 3 to 5 min. Do not allow the mold shell to contact either press platen at any time during this preforming step. The final pressure attained, if not recommended by the manufacturer of the particular material, shall be 34.5 MPa (5000 psi) for Type I and 17.2 MPa (2500 psi) for Types II, III and IV. Hold under maximum pressure for 2 to 5 min. Release the pressure by gradually “cracking” the pressure release valve without an apparent movement of the press platens. Remove the top pusher and force the preform vertically out of the mold shell using a continuous, smooth movement.

NOTE 7—Remove the mold in a careful smooth movement from the die to prevent cracking.

9.3.3 Sinter the preform in accordance with Table 3 (Note 4).

9.3.3.1 Use Procedure D for Types I, II and IV and Procedure E for Type III—except for ESG specimens.

9.3.3.2 For ESG specimens use Procedure H for Types I, II, and IV and Procedure I for Type III.

9.3.4 Divide the test billet into sections by making transverse cuts by machining, or by a suitable alternate procedure, in accordance with Fig. 4. Use a saw for the rough cuts between Sections I and II and between sections III and IV, but Faces C and D must be prepared by machining. Prepare five test specimens for the determination of tensile properties from 0.8-mm (1/32-in.) thick slices machined from Section II, Face C, and machine a slice of suitable thickness for standard specific gravity measurements as described in 10.5. Care shall be taken to avoid wedge-shaped cuts. Use the remainder of Section II to prepare tape specimens by skiving 0.13 mm (5 mils) thick. Discard the initial five revolutions of skived tape before taking the test sample. Use the tape for the determination of tensile properties, as an alternative to machined disks. If electrical properties, discussed in the Appendix, are to be determined on tape, Sections II and III must be left together in order that a tape of sufficient width is obtained to allow the cutting of a 50.8-mm (2-in.) diameter electrical test specimen.

9.4 Conditioning Test Specimens:

9.4.1 For tests of tensile properties and all tests requiring the measurement of specific gravity condition the test specimens in general accordance with Procedure A of Practice D618, with the following deviations therefrom: a) the aging period shall be a

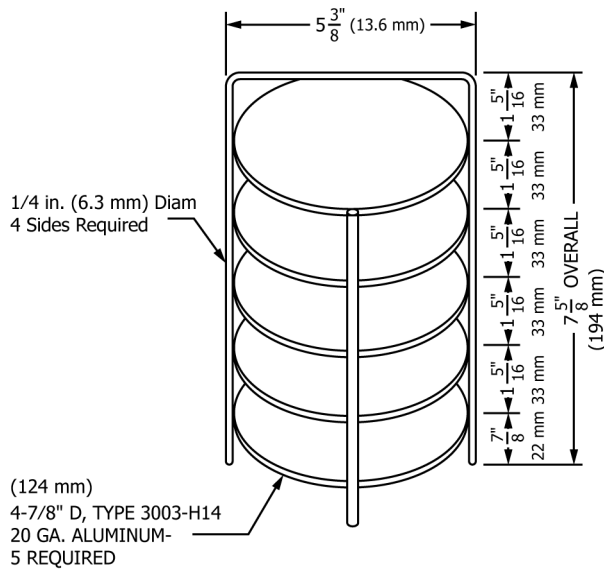

NOTE: ALUMINUM PLATES
TACK WELDED TO RODS

FIG. 2 SSG Samples Sintering Rack

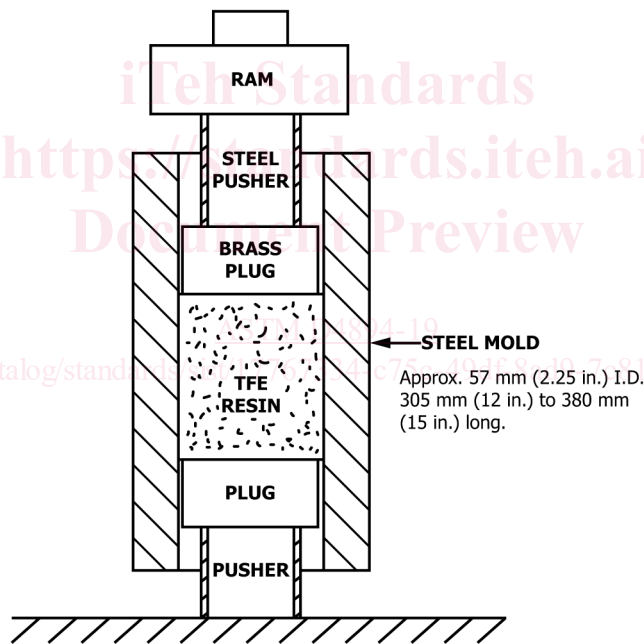

FIG. 3 Preforming of PTFE Test Billet

minimum of 4 h immediately prior to testing, b) the laboratory temperature shall be $23 \pm 2^\circ\text{C}$ ($73.4 \pm 3.6^\circ\text{F}$), and c) there shall be no requirement respecting humidity. The other tests require no conditioning of the molded test specimens.

9.5 Test Conditions:

9.5.1 Tests shall be conducted at the standard laboratory temperature of $23 \pm 2^\circ\text{C}$ ($73.4 \pm 3.6^\circ\text{F}$). See Note 5 for additional details. Since these resins do not absorb water, the maintenance of constant humidity during testing is not required.

10. Test Methods

10.1 Melting Characteristics by Thermal Analysis:

10.1.1 Significance and Use—Most of the PTFE resins that fall within the scope of this specification have never been melted (the only exception is Type V resin). These resins have higher melting peak temperatures on initial melting than on second or subsequent meltings. Since PTFE resins that have been melted prior to use behave differently from those that have not, the melting characteristics of resins provide important distinctions among them. Melting peak temperatures (see Fig. 5) are used to make these