



Designation: **D7756—18 D7756 – 19**

Standard Test Method for Residues in Liquefied Petroleum (LP) Gases by Gas Chromatography with Liquid, On-Column Injection¹

This standard is issued under the fixed designation D7756; the number immediately following the designation indicates the year of original adoption or, in the case of revision, the year of last revision. A number in parentheses indicates the year of last reapproval. A superscript epsilon (ϵ) indicates an editorial change since the last revision or reapproval.

1. Scope*

1.1 This test method covers the determination, by gas chromatography, of soluble hydrocarbon materials, sometimes called “oily residue,” which can be present in liquefied petroleum (LP) gases and which are substantially less volatile than the LPG product.

1.2 This test method quantifies, in the range of 10 mg/kg to 600 mg/kg (ppm mass), the residue with a boiling point between 174 °C and 522 °C (C₁₀ to C₄₀) in LPG. Higher boiling materials, or materials that adhere permanently to the chromatographic column, will not be detected.

1.3 ~~Appendix X3, Appendix X4 and, Appendix X4 and Appendix X6~~ describe additional applications which could be performed based on the hardware and procedures described in this test method. ~~Appendix X3~~ describes a test procedure for expanding the analysis range to benzene, ~~and Appendix X4~~ describes a test procedure for the analysis of ~~diisopropanolamine~~ diisopropanolamine, ~~and Appendix X6~~ describes a test procedure for the analysis of heavy residues or contaminants from C₄₀ to about C₆₀ in LPG.

1.4 The values stated in SI units are to be regarded as standard. The values given in parentheses after SI units are provided for information only and are not considered standard.

1.5 *This standard does not purport to address all of the safety concerns, if any, associated with its use. It is the responsibility of the user of this standard to establish appropriate safety, health, and environmental practices and determine the applicability of regulatory limitations prior to use.*

1.6 *This international standard was developed in accordance with internationally recognized principles on standardization established in the Decision on Principles for the Development of International Standards, Guides and Recommendations issued by the World Trade Organization Technical Barriers to Trade (TBT) Committee.*

2. Referenced Documents

2.1 ASTM Standards:²

[D1265 Practice for Sampling Liquefied Petroleum \(LP\) Gases, Manual Method](#)

[D1835 Specification for Liquefied Petroleum \(LP\) Gases](#)

[D2158 Test Method for Residues in Liquefied Petroleum \(LP\) Gases](#)

[D2163 Test Method for Determination of Hydrocarbons in Liquefied Petroleum \(LP\) Gases and Propane/Propene Mixtures by Gas Chromatography](#)

[D2421 Practice for Interconversion of Analysis of C₅ and Lighter Hydrocarbons to Gas-Volume, Liquid-Volume, or Mass Basis](#)

[D2598 Practice for Calculation of Certain Physical Properties of Liquefied Petroleum \(LP\) Gases from Compositional Analysis](#)

[D3700 Practice for Obtaining LPG Samples Using a Floating Piston Cylinder](#)

[D6299 Practice for Applying Statistical Quality Assurance and Control Charting Techniques to Evaluate Analytical Measurement System Performance](#)

[D6300 Practice for Determination of Precision and Bias Data for Use in Test Methods for Petroleum Products and Lubricants](#)

[D6667 Test Method for Determination of Total Volatile Sulfur in Gaseous Hydrocarbons and Liquefied Petroleum Gases by Ultraviolet Fluorescence](#)

[E355 Practice for Gas Chromatography Terms and Relationships](#)

¹ This test method is under the jurisdiction of ASTM Committee D02 on Petroleum Products, Liquid Fuels, and Lubricants and is the direct responsibility of Subcommittee D02.H0 on Liquefied Petroleum Gas.

Current edition approved Oct. 1, 2018; May 1, 2019. Published November 2018; June 2019. Originally approved in 2011. Last previous edition approved in 2013 as D7756—13; D7756 – 18. DOI:10.1520/D7756-18; DOI:10.1520/D7756-19.

² For referenced ASTM standards, visit the ASTM website, www.astm.org, or contact ASTM Customer Service at service@astm.org. For *Annual Book of ASTM Standards* volume information, refer to the standard's Document Summary page on the ASTM website.

*A Summary of Changes section appears at the end of this standard

E594 Practice for Testing Flame Ionization Detectors Used in Gas or Supercritical Fluid Chromatography

3. Terminology

3.1 *Definitions of Terms Concerning Chromatography*—This test method makes reference to many common gas chromatographic procedures, terms, and relationships. Detailed definitions of these can be found in Practices [E355](#) and [E594](#).

3.2 *Definitions of Terms Concerning Liquefied Petroleum Gases*—This test method makes reference to the definitions of liquefied petroleum gases as described in Specification [D1835](#).

3.3 *Definitions of Terms Specific to This Standard:*

3.3.1 *high pressure liquefied gas injector, n*—~~Sample~~sample introduction device which injects liquefied gas samples under pressure and at room temperature directly onto the chromatographic column thereby maintaining the sample in liquid phase during the injection process.

3.3.2 *pressure station, n*—~~Device~~device that supplies high pressure nitrogen to a suitable sample cylinder and therefore maintains sample in the liquid phase during the injection procedure.

4. Summary of Test Method

4.1 A sample cylinder of LPG is pressurized to 2500 kPa (363 psi) using nitrogen or helium.

4.2 The injection system is flushed with LPG in liquid phase at room temperature.

4.3 After flushing, the injection device is routed to the GC injector port and LPG (25 milliseconds activation time equivalent to 30 μ L) is introduced via a high pressure valve and needle which is inserted into a large volume cold on-column injector.

4.4 The gas chromatograph is equipped with a solvent vent which routes most of the LPG light components out of the analytical system and leaves behind the components of interest.

4.5 The oily residue to be determined is retained on a pre-column.

4.6 After venting the LPG, the flow from the pre-column is switched to the analytical column and a temperature program is started.

4.7 Oily residue contaminants are separated and identified based on differences in boiling point temperature.

4.8 Total residue is quantified using area summation of components corresponding to the expected range of C_{10} to C_{40} (174 °C to 522 °C).

5. Significance and Use

5.1 Control over the residue content as specified in Specification [D1835](#) is of considerable importance in end-use applications of LPG. Oily residue in LPG is contamination which can occur during production, transportation, or storage.

5.2 This test method is quicker and much more sensitive than manual methods, such as Test Method [D2158](#), which is based on evaporation of large sample volumes followed by visual or gravimetric estimation of residue content.

5.3 This test method provides enhanced sensitivity in measurements of heavier (oily) residues, with a quantification limit of 10 mg/kg total residue.

5.4 This test method gives both quantitative results and information about contaminant composition such as boiling point range and fingerprint, which can be very useful in tracing the source of a particular contaminant.

6. Apparatus

6.1 *Gas Chromatograph (GC)*—Gas chromatographic instrument equipped with a large volume cold on-column injector (LVOCI), a linear temperature programmable column oven, and a flame ionization detector (FID). The temperature control shall be capable of obtaining a retention time repeatability of 0.05 min (3 s) throughout the scope of this analysis.

6.2 *Data Acquisition*—Any commercial integrator or computerized data acquisition system may be used for display of the chromatographic detector signal and peak area integration.

6.3 *Solvent Vent*—A controlled vent for venting the major part of the matrix.

6.4 *Retention Gap*—Uncoated stainless steel capillary. Successfully used columns and conditions are given in [Table 1](#).

6.5 *Retaining Pre-Column*—A column with a polydimethylsiloxane stationary phase. Successfully used columns and conditions are given in [Table 1](#).

6.6 *Analytical Column*—A column with a polydimethylsiloxane stationary phase. Successfully used columns and conditions are given in [Table 1](#).

6.7 *Column Coupler—Coupling Device*—Suitable for leak-free coupling of the retention gap to the retaining pre-column. (See [Fig. 1](#) for a schematic overview of the couplings inside the GC oven and the couplings to the solvent vent valve.)

TABLE 1 Typical Operating Conditions

Oven program	35 °C for 3 min 35 °C to 340 °C at 25 °C/min 340 °C for 10 min
Inlet program	Type: cool on-column Temperature: 65 °C for 3 min 55 °C to 340 °C at 25 °C/min 340 °C for 9 min
Detector settings	Air flow: 400 mL/min Hydrogen flow: 40 mL/min Make up gas flow: 45 mL/min Temperature: 350 °C Data rate: 20 Hz
Column	Retention gap: Sulfinert ^A stainless steel capillary with inner diameter 0.53 mm and length of 5 m Retaining pre-column: 3 m 100 % Dimethylpolysiloxane: 0.53 mm, 2.65 µm Analytical column: 100 % Dimethylpolysiloxane 30 m, 0.32 mm, 0.25 µm
Pressure station	Sample flow: 2 mL/min Nitrogen pressure: 2500 kPa Nitrogen purge pressure: 500 kPa
Liquefied Gas Injector	Injection: 25 ms

^A Sulfinert is a trademark of SilcoTek, 112 Benner Circle, Bellefonte, PA 16823, www.SilcoTek.com.

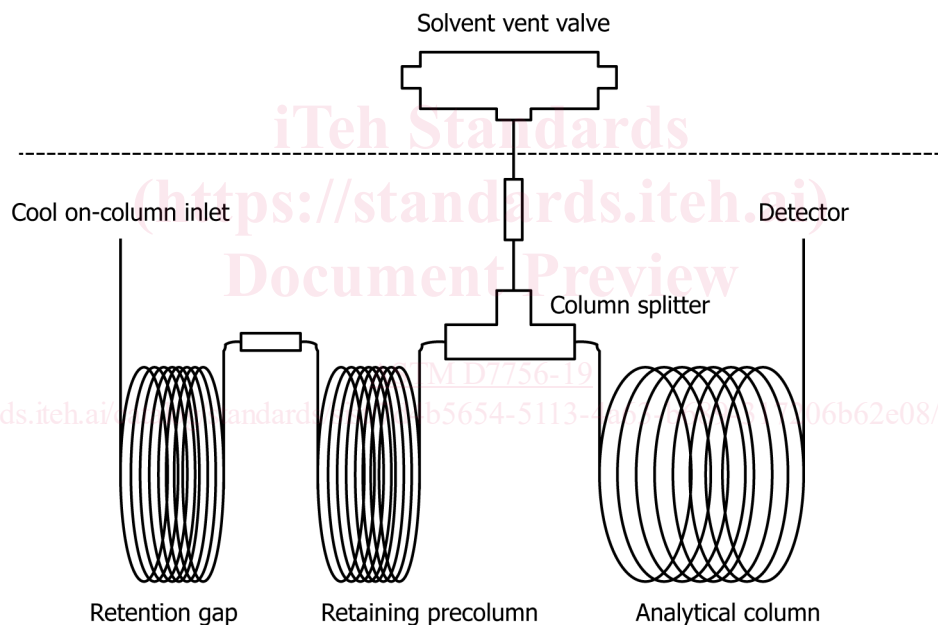

FIG. 1 Overview of the Couplings Inside the GC Oven and the Couplings to the Solvent Vent Valve

6.8 *Column Splitter*—Splitter suitable for leak-free coupling of the retaining pre-column to one side of the analytical column and the deactivated capillary on the other side. (See Fig. 1 for a schematic overview of the couplings inside the GC oven and the couplings to the solvent vent valve.)

6.9 *High Pressure Liquefied Gas Injector*—A high pressure valve directly connected to a needle which is inserted in the injection port of the GC, after which the valve is triggered in order to introduce a representative aliquot into the GC system without sample discrimination. (See Fig. 2.)

6.10 *Pressure Station*—This shall ensure a sample in liquid phase at a constant pressure. See Fig. 3 for a typical configuration.

6.11 *Typical Column Overview*—See Fig. 1.

6.12 *Typical Operating Conditions*—See Table 1.

7. Reagents and Materials

7.1 *Mineral Oil in LPG Calibration Mixture*—Certified calibration mixture with mineral oil in LPG. The concentration of the mineral oil shall be close to the expected concentration of the contamination in the LPG sample.

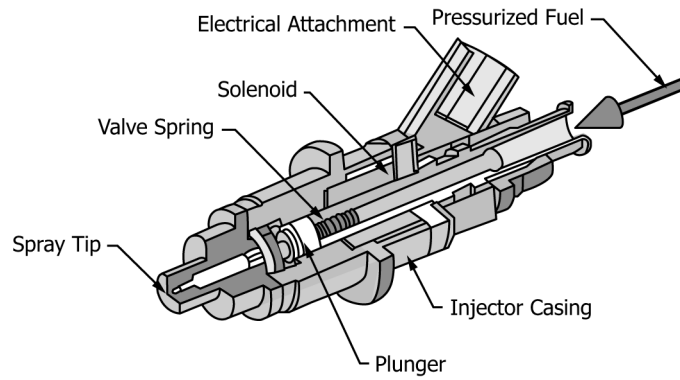
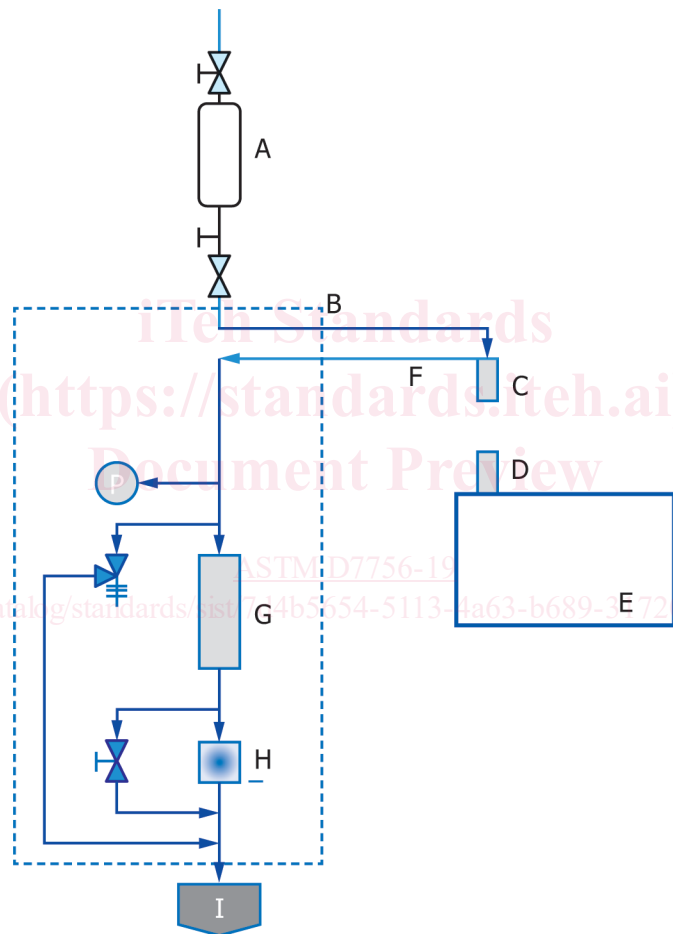

FIG. 2 High Pressure Valve



- | | |
|---|----------------------|
| A | Sample cylinder |
| B | Sample line in |
| C | Injection device |
| D | Cool on-column inlet |
| E | Gas chromatograph |
| F | Sample line out |
| G | Rotometer |
| H | Vaporizer |
| I | Waste system |
| P | Pressure gauge |

FIG. 3 Typical Configuration of a Pressure Station

7.2 *Mineral Oil in Pentane Calibration Mixture*—Prepare a calibration standard of mineral oil in pentane. Record the weighed value to the nearest milligram of mineral oil and calculate the concentration in mg/kg. The concentration of the mineral oil shall be close to the expected concentration of the contamination in the LPG sample.

7.2.1 Standards that are prepared in pentane, normally liquid at room temperature, should be stored in suitable containers under refrigeration and transferred to sample cylinders prior to use. Alternatively, they may be stored in airtight cylinders.

7.3 *Mineral Oil or Local Hydrocarbon Fraction*—Boiling point range approximately C_{10} to C_{40} . Alternatively, a ~~well characterized~~ well-characterized local hydrocarbon fraction, within the range C_{10} to C_{40} , can be used to provide quantitative and qualitative comparison to the contaminant in the sample. Care should be taken to ensure no significant fraction falls outside the C_{10} to C_{40} range.

7.4 *Validation Standard, Mineral Oil in Pentane*—Prepare a validation standard of mineral oil in pentane. Record the exact weighed value to the nearest milligram of mineral oil and calculate the concentration in mg/kg. The concentration of the mineral oil shall be close to the expected concentration of the contamination in the LPG sample.

7.5 *N-alkane Retention Time Standard*—Mixture containing at least C_{10} and C_{40} in a concentration of (nominally) 5 mg/L each, dissolved in pentane or heptane.

7.6 *Solvent*—GC grade pentane.

8. Hazards

8.1 There is a significant fire hazard from LPG, and since the boiling point of LPG can be as low as $-41\text{ }^{\circ}\text{C}$, there is a risk of freezing “burns.” Take appropriate safety precautions to prevent ignition or fire, and wear suitable protective equipment to protect against skin contact with LPG.

8.2 An appropriate laboratory ventilation system shall be used.

8.3 An appropriate waste line shall be installed. The pressure station and injector shall be connected to this line. The waste line should vent outside the building.

8.4 Pressure station, cylinder, injector, and controller shall be grounded appropriately.

9. Preparation of Apparatus

9.1 *Gas Chromatograph*—Install and verify performance in accordance with the manufacturer’s instructions. Typical operating conditions are shown in [Table 1](#).

9.2 *Pressure Station*—Install in accordance with the manufacturer’s instructions. Purge sample and check carefully for leaks.

9.3 *High Pressure Liquefied Gas Injector*—Install in accordance with the manufacturer’s instructions.

9.4 *Column Configuration*—Install the columns as shown in [Fig. 1](#). Use low dead volume connections, and check for leaks.

10. Calibration

10.1 Perform a ~~one-point~~ one-point calibration at the startup of the instrument, when the result of the validation sample falls outside the acceptable SQC limits in accordance with [Section 14](#) or after changes in the application hardware or gas supply, or both.

10.2 To verify system linearity over the range of expected sample residues, a linearity check should be performed. More information can be found in [Appendix X5](#).

10.3 Run a blank run, without sample injection. Cycle the GC several times until the baseline is stable. A baseline is stable when the start and end signal (in pA) of two consecutive blank runs are within 5 %. An unstable baseline can be caused by a leak, detector gases, or by high boiling point components or materials that have not yet eluted from the column. The signal height (in pA) at the end of an analysis of a calibration, validation, or sample shall be equal or higher than the blank baseline. A signal higher than 5 % could indicate a poorly conditioned column or the elution of sample components with a boiling point higher than $522\text{ }^{\circ}\text{C}$. Refer to the datasheet of the column for instructions on conditioning the column.

10.4 Analyze the n-alkane retention time standard ([7.6](#)), and establish the retention time for C_{10} and C_{40} . There should be baseline separation between the solvent and the first normal alkane peak (C_{10}). If the separation is not sufficient, adjust the temperature program, re-establish the baseline, and then reanalyze the retention time standard. An example is shown in [Fig. 4](#).

10.5 Analyze the calibration mixture. The calibration mixture is either in LPG or in pentane ([7.1](#) and [7.2](#)).

10.6 Integrate the oily residue by summing the area from C_{10} through C_{40} .

10.7 Determine the response factor by dividing the known concentration by the total area, and use this for the calculation of unknown samples under the assumption that all sample components have the same response factor.

10.8 Analyze the validation sample using the liquefied gas injector. Analyze the validation sample once per day of use before the samples. Repeat the analysis when the result of the validation sample falls outside the acceptable SQC limits in accordance with [Section 14](#).

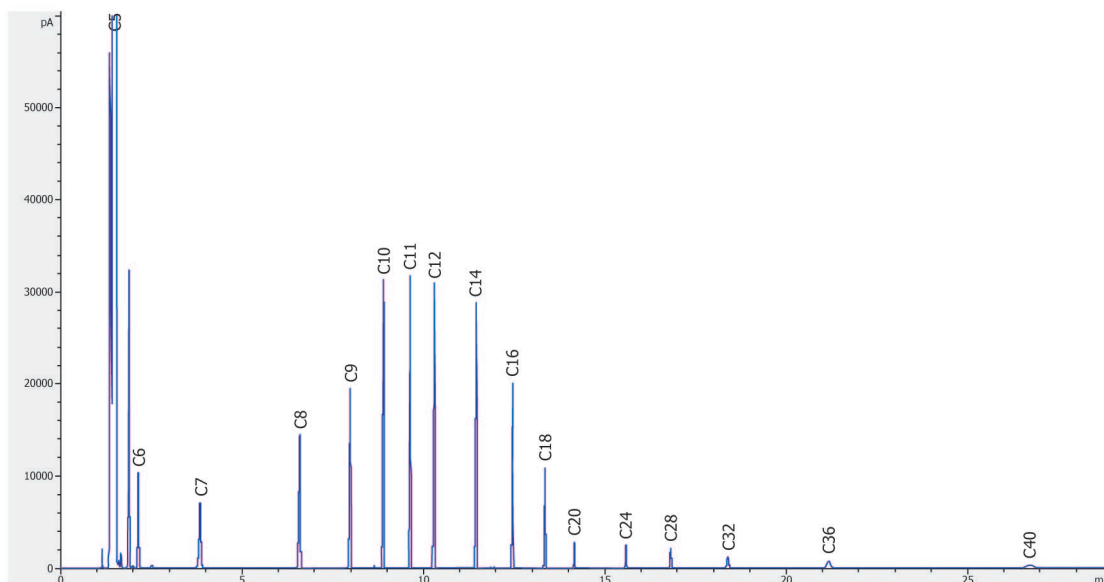

**FIG. 4 Chromatogram of C₁₀ through C₄₀:
oven 40 °C 5 min, 40 °C to 325 °C at 25 °C/min, 325 °C for 13.6 min**

11. Procedure

- 11.1 Collect a representative sample according to Practice [D1265](#) or [D3700](#).
- 11.2 Connect the sample cylinder to the pressure station and pressurize to approximately 2500 kPa ± 200 kPa (363 psi ± 29 psi). It is important to maintain and reproduce this pressure as closely as possible to ensure sample size injection repeatability.
- 11.3 Open the cylinder at both sides and flush the sample for approximately 3 min with a flow rate of about 5 mL/min.
- 11.4 Inject sample (trigger pulse 25 ms at 2500 kPa, equivalent to approximately 30 µL).
- 11.5 Analyze each sample in duplicate. If the difference between the results of the two analyses is >5 %, perform an extra analysis and average the two closest results.
- 11.6 Close the sample cylinder after injection and repeat [11.3](#) for the next injection. When all analyses are finished, close the sample cylinder and release the system pressure. Remove the sample cylinder.
- 11.7 Integrate the oily residue by summing the area from C₁₀ through C₄₀.
- 11.8 To inject the validation sample, fill a sample cylinder with the standard and use the same injection procedure as for LPG samples.

12. Calculation or Interpretation of Results

- 12.1 Verify whether the separation between the matrix peak and C₁₀ is sufficient for correct integration of the residue. An example is shown in [Fig. 5](#).
- 12.2 Start the integration at the retention time of C₁₀ or at the point where the slope of the solvent peak reaches a minimum (the valley). This point should not be higher than two times the value of the baseline in pA.
- 12.3 Calculation is based on a response factor and correction for the difference in density between the sample and the calibration mixture. Correction for the difference in density between the sample and the calibration standard is performed as in Test Method [D6667](#) (see [Appendix X1](#)).
- 12.4 Calculation of the response factor, using the calibration mixture:

$$Rf = Scg/Ac \quad (1)$$

where:

- Rf* = Response factor,
Scg = Mineral oil content in the LPG calibration standard or in the standard in pentane in mg/kg weight, and
Ae = Summed area of the peaks in the range of C₁₀ to C₄₀ in the LPG calibration standard or in the pentane standard.

- Rf* = response factor,
Scg = mineral oil content in the LPG calibration standard or in the standard in pentane in mg/kg weight, and