



Designation: **G47–98 (Reapproved 2011) G47 – 98 (Reapproved 2019)**

## Standard Test Method for Determining Susceptibility to Stress-Corrosion Cracking of 2XXX and 7XXX Aluminum Alloy Products<sup>1</sup>

This standard is issued under the fixed designation G47; the number immediately following the designation indicates the year of original adoption or, in the case of revision, the year of last revision. A number in parentheses indicates the year of last reapproval. A superscript epsilon ( $\epsilon$ ) indicates an editorial change since the last revision or reapproval.

*This standard has been approved for use by agencies of the U.S. Department of Defense.*

### 1. Scope

1.1 This test method covers a uniform procedure for characterizing the resistance to stress-corrosion cracking (SCC) of high-strength aluminum alloy wrought products for the guidance of those who perform stress-corrosion tests, for those who prepare stress-corrosion specifications, and for materials engineers.

1.2 This test method covers method of sampling, type of specimen, specimen preparation, test environment, and method of exposure for determining the susceptibility to SCC of 2XXX (with 1.8 to 7.0 % copper) and 7XXX (with 0.4 to 2.8 % copper) aluminum alloy products, particularly when stressed in the short-transverse direction relative to the grain structure.

1.3 The values stated in SI units are to be regarded as standard. The inch-pound units in parentheses are provided for information.

1.4 *This standard does not purport to address all of the safety concerns, if any, associated with its use. It is the responsibility of the user of this standard to establish appropriate safety, health, and environmental practices and determine the applicability of regulatory limitations prior to use.*

1.5 *This international standard was developed in accordance with internationally recognized principles on standardization established in the Decision on Principles for the Development of International Standards, Guides and Recommendations issued by the World Trade Organization Technical Barriers to Trade (TBT) Committee.*

### 2. Referenced Documents

2.1 *ASTM Standards:*<sup>2</sup>

**G38** Practice for Making and Using C-Ring Stress-Corrosion Test Specimens

**G44** Practice for Exposure of Metals and Alloys by Alternate Immersion in Neutral 3.5 % Sodium Chloride Solution

**G49** Practice for Preparation and Use of Direct Tension Stress-Corrosion Test Specimens

**G139** Test Method for Determining Stress-Corrosion Cracking Resistance of Heat-Treatable Aluminum Alloy Products Using Breaking Load Method

### 3. Summary of Test Method

3.1 This test method provides a comprehensive procedure for accelerated stress-corrosion testing high-strength aluminum alloy product forms, particularly when stressed in the short-transverse grain direction. It specifies tests of constant-strain-loaded, 3.18-mm (0.125-in.) tension specimens or C-rings exposed to 3.5 % sodium chloride (NaCl) solution by alternate immersion, and includes procedures for sampling various manufactured product forms, examination of exposed test specimens, and interpretation of test results.

### 4. Significance and Use

4.1 The 3.5 % NaCl solution alternate immersion test provides a test environment for detecting materials that would be likely to be susceptible to SCC in natural outdoor environments, especially environments with marine influences.<sup>3,4,5</sup> For determining

<sup>1</sup> This test method, which was developed by a joint task group with the Aluminum Association, Inc., is under the jurisdiction of ASTM Committee G01 on Corrosion of Metals and is the direct responsibility of Subcommittee G01.06 on Environmentally Assisted Cracking.

Current edition approved Sept. 1, 2011; June 15, 2019. Published September 2011; June 2019. Originally approved in 1976. Last previous edition approved in 2004 as G47-98(2004); G47-98 (2011). DOI: 10.1520/G0047-98RH; 10.1520/G0047-98R19.

<sup>2</sup> For referenced ASTM standards, visit the ASTM website, www.astm.org, or contact ASTM Customer Service at service@astm.org. For *Annual Book of ASTM Standards* volume information, refer to the standard's Document Summary page on the ASTM website.

<sup>3</sup> Romans, H. B., *Stress Corrosion Testing*, ASTM STP 425, ASTM, 1967, pp. 182–208.

actual serviceability of a material, other stress-corrosion tests should be performed in the intended service environment under conditions relating to the end use, including protective measures.

4.2 Although this test method is intended for certain alloy types and for testing products primarily in the short-transverse stressing direction, this method is useful for some other types of alloys and stressing directions.

## 5. Interferences

5.1 A disadvantage of the 3.5 % NaCl solution alternate immersion test is that severe pitting may develop in the specimens. Such pitting in tension specimens with relatively small cross section can markedly reduce the effective cross-sectional area and produce a net section stress greater than the nominal gross section stress, resulting in either: (1) fracture by mechanical overload of a material that is not susceptible to SCC; or (2) SCC of a material at an actual stress higher than the intended nominal test stress. The occurrence of either of these phenomena might then interfere with a valid evaluation of materials with relatively high resistance to stress corrosion.

## 6. Test Specimen

6.1 *Type and Size*—No single configuration of test specimen is applicable for the many complex shapes and sizes of products that must be evaluated. A tension specimen is preferred because it more consistently provides definite evidence of cracking and should be used whenever the size and shape of the product permits; it also provides a more severe test.

6.1.1 *Tension Specimen*—The diameter of the reduced section shall be  $3.17 \pm 0.03$  mm ( $0.125 \pm 0.001$  in.).

6.1.2 *C-Ring (see Practices G38)*—The use of C-rings permits short-transverse tests to be made of sections that are too thin or complex for practical tests with a tension specimen. C-rings may be of various sizes as required for the product to be tested, but in no case less than  $15.88 \pm 0.05$  mm ( $0.625 \pm 0.002$  in.) in outside diameter. The ratio of diameter to wall thickness shall be kept in the range from 11:1 to 16:1.

6.2 *Stressing Direction:*

6.2.1 *Short-Transverse Tests:*

6.2.1.1 For specified material thicknesses of 38.10 mm (1.500 in.) and over, the tension specimen shall be used.

6.2.1.2 For specified material thicknesses of 17.78 through 38.08 mm (0.700 through 1.499 in.), a C-ring shall be used. A tension specimen may be used if consistent with the provisions of Practice G49.

6.2.2 For other stress directions in materials of 6.35 mm (0.250 in.) and over, the tension specimen shall be used.

6.3 *Surface Preparation*—Test specimens shall be degreased prior to exposure.

## 7. Sampling and Number of Tests

7.1 Unless otherwise specified, tests shall be performed in the short-transverse direction; the intention is to orient the specimen so that the applied tensile stress is perpendicular to the metal flow lines and in the short-transverse direction relative to the grain structure. In rolled or extruded sections that are approximately round or square, there is no true short-transverse direction because in a transverse plane the grains tend to be equiaxial; and, in such cases, the stress should be directed simply in the transverse direction. If, in certain unusual cases, the grain structure is or tends to be equiaxial also in the longitudinal direction, the stress shall be applied in a direction parallel to the smallest dimension of the product.

7.2 *Location of Specimens:*

7.2.1 For products stress relieved by stretching (TX51, TX510, TX511, TXX51, TXX510, TXX511), samples shall not be taken from the portion under the stretcher grips.

7.2.2 *Rolled Plate*—Short-transverse specimens shall be taken so that the region of maximum stress is centered on the mid-plane of the plate and at least  $2\frac{1}{2}$  plate thicknesses away from a side of the plate. (The side of the plate is defined as the edge parallel to the rolling direction.)

7.2.3 *Hand Forgings*—Short-transverse specimens shall be taken so that the stress is applied in a direction perpendicular to the forging flow lines. The region of maximum stress shall be centered in the forging thickness and approximately on the longitudinal center line of the forging, no less than  $\frac{1}{2}$  the section thickness away from “as-heat treated” edges of the forging.

7.2.4 *Die Forgings*—Because of the wide variety of configurations of die forgings, guidelines are provided for only certain common types of shapes that are widely used. Short-transverse specimens shall be taken so that the stress is applied in a direction perpendicular to the forging flow lines and, if possible, with the region of maximum stress centered on the parting plane. The metal flow pattern in die forgings cannot always be predicted, so only a few general rules are given, and they are illustrated in Fig. 1. Departures from these rules should be made only on the basis of a study of forging flow lines indicating that the intended type of test would not be obtained. In every case, a diagram should be filed with the test results to illustrate specimen locations and orientations.

<sup>4</sup> Brown, R. H., Spowls, D. O., and Shumaker, M. B., “The Resistance of Wrought High Strength Aluminum Alloys to Stress Corrosion Cracking,” *Stress Corrosion Cracking of Metals—A State of the Art, ASTM STP 518*, ASTM, 1972, pp. 87–118.

<sup>5</sup> Spowls, D. O., Summerson, T. J., Ugiansky, G. M., Epstein, S. G., and Craig, H. L., Jr., “Evaluation of a Proposed Standard Method of Testing for Susceptibility to Stress-Corrosion Cracking of High-Strength 7XXX Series Aluminum Alloy Products,” *Stress Corrosion—New Approaches, ASTM STP 610*, ASTM, 1976, pp. 3–31.

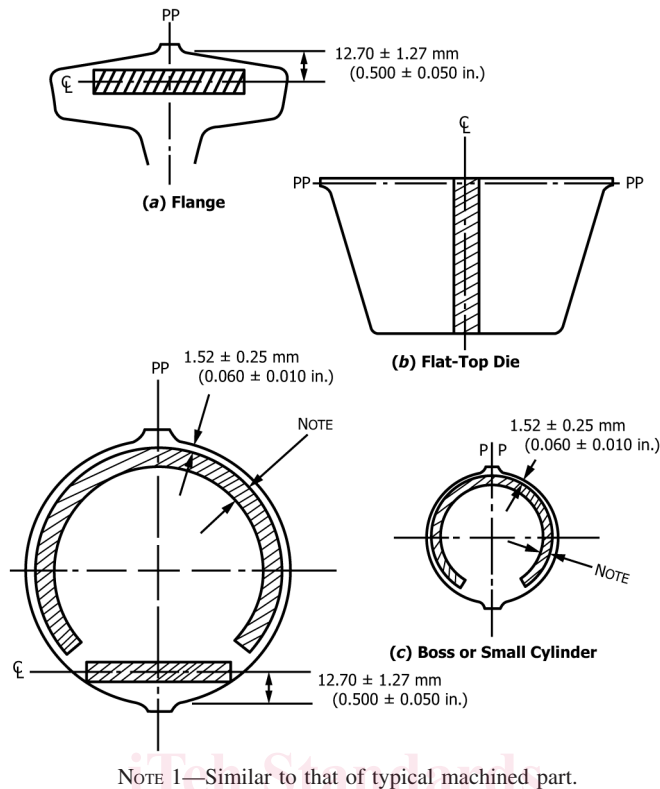

NOTE 1—Similar to that of typical machined part.  
**FIG. 1 Recommended Specimen Type and Location for Various Configurations of Die Forgings**

(<https://standards.iteh.ai>)

7.2.4.1 *Flanges*—The centerline of the specimen shall be  $12.70 \pm 1.27$  mm ( $0.500 \pm 0.050$  in.) from the base of the fillet of the flash except for flanges that are too thin, in which case, the specimen should be centered.

7.2.4.2 *Flat-Top Die*—The tension specimen should be perpendicular to the parting plane and, if possible, centered in the width.

7.2.4.3 *Boss or Small Cylinder*—The C-ring specimen should be centered on the parting plane and with the outside diameter of the ring being  $1.52 \pm 0.25$  mm ( $0.060 \pm 0.010$  in.) from the forging surface (see Fig. 1).

7.2.4.4 *Large Cylinder*—The centerline of tension specimens shall be  $12.70 \pm 1.27$  mm ( $0.500 \pm 0.050$  in.) from the base of the flash. If a C-ring is required, its outside diameter shall be  $1.52 \pm 0.25$  mm ( $0.060 \pm 0.010$  in.) from the forging surface (see Fig. 1).

7.2.5 *Extruded, Rolled, or Cold Finished Rod, Bar, and Shapes:*

7.2.5.1 *Width-to-Thickness Ratio Greater than 2*—Short-transverse specimens shall be taken so that the region of maximum stress is centered in the section thickness, at least one section thickness away from the sides of the product. In the case of complex configurations for which the grain directionality cannot be predicted, specimen location shall be determined by means of macroetched transverse sections to ensure a short-transverse specimen and to avoid regions of nearly equiaxial (transverse) grain flow.

7.2.5.2 *Width-to-Thickness Ratio of 2 or Less*—Specimens shall be centered in the section thickness so that the region of maximum stress application will be at least one half the section thickness away from a fabricated surface, if possible. These specimens shall be considered to have a “transverse” orientation to the grain structure. When C-rings are required, they shall be taken so that the region of maximum tensile stress is  $3.18 \pm 0.25$  mm ( $0.125 \pm 0.010$  in.) from the product surface.

7.3 *Number of Specimens*—For each sample, which shall be uniform in thickness and grain structure, a minimum of three adjacent replicate specimens shall be tested.

## 8. Test Environment

8.1 *Corrosion Test Environment*—Specimens shall be exposed to the alternate 10-min immersion—50-min drying cycle in accordance with Practice G44.

8.2 *Length of Exposure*—The test duration for 3.18-mm (0.125-in.) tension specimens and C-rings shall be 10 days for 2XXX alloys or 20 days for 7XXX alloys, unless cracking occurs sooner. For specimens to be tested in the long transverse direction, the test duration should be 40 days. Longer nonstandard test durations are likely to cause failures of the 3.18-mm tension specimens as a result of severe pitting as described in 5.1. There shall be no interruptions except as required for periodic inspection of specimens or changing of the solution.