



Designation: **F2201 – 10 F2201 – 19**

Standard Consumer Safety Specification for Utility Lighters¹

This standard is issued under the fixed designation F2201; the number immediately following the designation indicates the year of original adoption or, in the case of revision, the year of last revision. A number in parentheses indicates the year of last reapproval. A superscript epsilon (ϵ) indicates an editorial change since the last revision or reapproval.

1. Scope

1.1 This consumer safety specification covers all flame-producing consumer products commonly known as utility lighters (also known as grill lighters, fireplace lighters, lighting rods, or gas matches) and such similar devices as defined in 3.1.14. Matches are specifically excluded from this specification; flame-producing products intended for igniting cigars, pipes, and cigarettes are also specifically excluded from this safety specification and are covered in Consumer Safety Specification F400.

1.2 This specification establishes requirements for utility lighters to ensure a reasonable degree of safety for normal use and reasonably foreseeable misuse of such utility lighters by users.

1.3 Utility lighters, being flame-producing devices, can, as can all flame sources, present a potential hazard to the user. This specification cannot eliminate all hazards, but it is intended to minimize potential hazards of utility lighters to users.

1.4 The values stated in SI units are to be regarded as the standard. The values given in parentheses are for information only.

1.5 All utility lighters are subject to the mandatory child resistance requirements found at 16 CFR Part 1212 and the labeling requirements found at 16 CFR Part 1500. See Annex A2.

1.5 The following precautionary caveat pertains only to the test methods portion, Section 8, of this specification. *This standard does not purport to address all of the safety concerns, if any, associated with its use. It is the responsibility of the user of this standard to establish appropriate safety, health, and environmental practices and determine the applicability of regulatory requirements prior to use.*

1.6 *This international standard was developed in accordance with internationally recognized principles on standardization established in the Decision on Principles for the Development of International Standards, Guides and Recommendations issued by the World Trade Organization Technical Barriers to Trade (TBT) Committee.*

2. Referenced Documents

2.1 ASTM Standards:²

[D2163 Test Method for Determination of Hydrocarbons in Liquefied Petroleum \(LP\) Gases and Propane/Propene Mixtures by Gas Chromatography](#)

[D2598 Practice for Calculation of Certain Physical Properties of Liquefied Petroleum \(LP\) Gases from Compositional Analysis](#)

[F400 Consumer Safety Specification for Lighters](#)

2.2 ~~Code of Federal Regulations: Other Standards:~~

~~[16 CFR Part 1212 UL 1439 Safety Standard for Multi-Purpose Lighters Test for Sharpness of Edges on Equipment](#)~~³

~~[ISO 7941 Commercial Propane and Butane – Analysis by Gas Chromatography](#)~~⁴

~~[16 CFR Part 1500 Federal Hazardous Substances Act Regulations](#)~~⁵

2.3 ~~Other Federal Documents:~~⁴

~~[15 USC Section 1261 Federal Hazardous Substances Act](#)~~

~~[15 USC Section 2056 Consumer Product Safety Act](#)~~

¹ This consumer safety specification is under the jurisdiction of ASTM Committee F15 on Consumer Products and is the direct responsibility of Subcommittee F15.02 on Safety Standards for Lighters.

Current edition approved May 1, 2019. Published June 2019. Originally approved in 2002. Last previous edition approved in 2002 as F2201 – 02 F2201 – 10. DOI: 10.1520/F2201-10.1520/F2201-19.

² For referenced ASTM standards, visit the ASTM website, www.astm.org, or contact ASTM Customer Service at service@astm.org. For Annual Book of ASTM Standards volume information, refer to the standard's Document Summary page on the ASTM website.

³ Available from U.S. Government Printing Office Superintendent of Documents, 732 N. Capitol St., NW, Mail Stop: SDE, Washington, DC 20401. Underwriters Laboratories (UL), 2600 N.W. Lake Rd., Camas, WA 98607-8542, http://www.ul.com.

⁴ Available from International Organization for Standardization (ISO), ISO Central Secretariat, BIBC II, Chemin de Blandonnet 8, CP 401, 1214 Vernier, Geneva, Switzerland, http://www.iso.org.

⁵ Available from U.S. Government Printing Office Superintendent of Documents, 732 N. Capitol St., NW, Mail Stop: SDE, Washington, DC 20401.

~~15 USC Section 2058 Consumer Product Safety Act~~

~~2.4 Military/ISO Standards:⁵~~

~~MIL-STD-105D (ISO 2859) Sampling Procedures and Tables for Inspection by Attributes~~

~~MIL-STD-414 (ISO 3951) Sampling Procedures and Tables for Inspection by Variables for Percent Defective~~

3. Terminology

3.1 *Definitions of Terms Specific to This Standard:*

3.1.1 *flame, n*—the result of combustion of fuel that produces heat and often light that could be visible to the naked eye under normal or subdued lighting conditions.

3.1.2 *flame height, n*—a linear distance from the tip of the visible flame to the end of the shield.

3.1.3 *flaring, n*—a variance of flame height from the steady-state flame condition.

3.1.4 *fuel, n*—a butane, isobutane, propane, or other liquefied hydrocarbon, or a mixture containing any of these, whose vapor pressure at 24°C (75°F) exceeds a gage pressure of 103 kPa (15 lbf/in.²).

3.1.5 *fuel reservoir, n*—a structure that stores the fuel prior to release.

3.1.6 *ignite, v*—to produce a flame with a utility lighter by activating the self-contained ignition and fuel release systems of that utility lighter in the intended manner.

3.1.7 *ignition system, n*—the system that generates a spark to ignite the fuel, such as a piezo mechanism or battery.

3.1.8 *nozzle, n*—the end of the fuel discharge system.

3.1.9 *postmixing burning utility lighter, n*—a gas utility lighter in which fuel and air are mixed at the point of combustion.

3.1.10 *premixing burner utility lighter, n*—a gas utility lighter in which fuel and air are mixed before being supplied for combustion.

3.1.11 *shield, n*—a structure that totally or partially surrounds the nozzle of the utility lighter.

3.1.12 *spitting or sputtering, n*—a flame phenomenon of a utility lighter wherein the escape of ~~nonevaporated~~non-evaporated or liquid fuel produces a shower of burning liquid droplets that separate from the main flame.

3.1.13 *sustained self-ignition, n*—the propagation of a flame by other than deliberate manual operation, such as by dropping the utility lighter, so as to cause the ignition system to be ~~activated~~activated, producing a flame, and the flame to continue to burn.

3.1.14 *utility lighter, n*—a hand-held, flame-producing device with a manually-operated ignition system, 4 in. or greater in length when in the fully extended position, employing a fuel as defined in 3.1.4, used primarily to ignite items such as candles, fuel for fireplaces, charcoal or gas-fired grills, camp stoves, lanterns, fuel-fired appliances or devices, pilot lights, or a combination of these.

3.1.14.1 *utility lighter, adjustable, n*—a utility lighter that is received by the user with a mechanism for the user to manually vary the height of the flame.

3.1.14.2 *utility lighter, disposable, n*—a utility lighter that is received by the user with a supply of fuel and that is not intended to be refueled.

3.1.14.3 *utility lighter, dual flame, n*—utility lighter that employs a burner valve system(s) that produces more than one type of flame (premixing and postmixing), which could be produced independently and separately (one flame at a time), or dependently and concurrently (multiple flames at a time).

3.1.14.4 *utility lighter, multiple flame, n*—utility lighter that employs a burner valve system(s) that produce more than one flame of the same type (premixing or postmixing), which could be produced independently and separately (one flame at a time), or dependently and concurrently (multiple flames at a time).

3.1.14.5 *utility lighter, nonadjustable, n*—a utility lighter that has a flame height preset by the manufacturer and is not provided with a mechanism to adjust the flame height.

3.1.14.6 *utility lighter, refillable, n*—a utility lighter that is intended to be refueled either by transferring fuel from an external container or by inserting a new prepackaged fuel reservoir.

3.1.14.7 *utility lighter, self-extinguishing, n*—a utility lighter that, once ignited, requires continuous intentional and positive action to maintain a flame and that is subsequently extinguished upon the termination of such positive action.

3.1.15 *valve, n*—the component of a utility lighter that controls the input or release of fuel.

4. General Requirements (Table 1)

4.1 *Flame Generation*—In order to minimize the possibility of inadvertent or self-ignition, utility lighters shall require a deliberate manual operation to produce a flame. These operations shall conform to at least one of the following requirements:

4.1.1 A system such that a positive action on the part of the user is required to generate and maintain a flame.

4.1.2 A system that requires two or more independent motions to generate a flame.

4.1.3 A system that requires an actuating force equal to or greater than 15 N (3.4 lbf) to generate a flame (see Fig. X2.11 for an example of test equipment):methods).

4.2 *Flame Control*—The maximum attainable flame height for utility lighters shall be limited with a setting, by product design, or by both. For adjustable flame height utility lighters, the maximum flame height that a user will obtain on first igniting the utility lighter without adjustment shall also be limited. These limits shall comply with the following requirements when tested in accordance with 8.1:

4.2.1 Nonadjustable postmixing burner utility lighters, as defined in 3.1.9 and 3.1.14.33.1.14.5, in the user’s hands shall have a maximum attainable flame height of no more than 100 mm (4 in.) with the flame directed vertically upward and when tested in accordance with 8.1, subject to Annex A1 for mandatory acceptable quality levels (AQLs) and Appendix X1 on sampling scheme references:

4.2.2 Nonadjustable premixing burner utility lighters, as defined in 3.1.10 and 3.1.14.33.1.14.5, in the user’s hands shall have a maximum attainable flame height of no more than 75 mm (3 in.) with the flame directed vertically upward when tested in accordance with 8.1, subject to Annex A1 for mandatory AQLs and Appendix X1 on sampling scheme references:

4.2.3 Adjustable, postmixing burner utility lighters, as defined in 3.1.9 and 3.1.14.1, shall not be capable of producing a flame height greater than 150 mm (6.0 in.) with the flame directed vertically upward when deliberately adjusted by the user to the manufacturer’s design limit for maximum flame height and when tested in accordance with 8.1, subject to Annex A1 for mandatory AQLs and Appendix X1 on sampling scheme references:

4.2.4 Adjustable, premixing burner utility lighters, as defined in 3.1.10 and 3.1.14.1, shall not be capable of producing a flame height greater than 75 mm (3 in.) with the flame directed vertically upward when deliberately adjusted by the user to the manufacturer’s design limit for maximum flame height and when tested in accordance with 8.1, subject to Annex A1 for mandatory AQLs and Appendix X1 on sampling scheme references:

4.2.5 Adjustable, postmixing burner utility lighters, as defined in 3.1.9 and 3.1.14.1, shall have the flame height adjusted by the manufacturer in such a manner that the utility lighter, when first ignited by the user without changing the adjustment, will not produce a flame height in excess of 100 mm (4 in.) with the flame directed vertically upward and when tested in accordance with 8.1, subject to Annex A1 for mandatory AQLs and Appendix X1 on sampling scheme references:

4.2.6 Adjustable, premixing burner utility lighters, as defined in 3.1.10 and 3.1.14.1, shall have the flame height adjusted by the manufacturer in such a manner that the utility lighter, when first ignited by the user without changing the adjustment, will not produce a flame height in excess of 60 mm (2.5 in.) with the flame directed vertically upward and when tested in accordance with 8.1, subject to Annex A1 for mandatory AQLs and Appendix X1 on sampling scheme references:

4.2.7 Adjustable, postmixing burner utility lighters, as defined in 3.1.9 and 3.1.14.1, shall be capable of producing a flame not in excess of 75 mm (3 in.) with the flame directed vertically upward when set at the lowest possible flame height and when tested in accordance with 8.1.

4.2.8 Adjustable, premixing burner utility lighters, as defined in 3.1.10 and 3.1.14.1, shall be capable of producing a flame not in excess of 50 mm (2 in.) with the flame directed vertically upward when set at the lowest possible flame height and when tested in accordance with 8.1.

4.3 *Flame-Height Adjustment*—Adjustable utility lighters, as defined in 3.1.14.1, shall require a deliberate action on the part of the user either to decrease or to increase the flame height when the utility lighter is used in the normal fashion.

4.3.1 If flame-height adjustment features protrude from the body of the utility lighter, it shall require a minimum actuating force of 1 N (0.25 lbf) applied over the entire range of adjustment in a tangential direction (see Fig. X2.22 for an example of the test equipment):example).



FIG. 1 Position of Specimen for the Burning Test Described in 5.4.2

FIG. 21 Position of Specimen for the Flame Height Measurement Described Block Diagram for a Typical Example of Test Method for Measuring the Flame Generation Actuating Force as Specified in 8.2.3.44.1.3

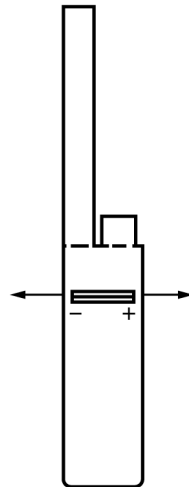

FIG. X2-12 Block Diagram for a Typical Example of Test Equipment-Method for Measuring the Flame Generation-Height Adjustment Feature Actuating Force as Specified in 4-1-34.3.1

4.3.2 Adjustable utility lighters having rotary movement flame-height adjustment features approximately at right angles to the flame shall perform as follows:

4.3.2.1 When the flame-height adjustment feature of the utility lighter is held so the flame is oriented vertically upward and the user is facing the flame-height adjustment, moving the actuator to the left shall produce a decrease in flame height.

4.3.3 Adjustable utility lighters requiring motion of the flame-height adjustment feature approximately parallel to the flame axis shall decrease or increase the flame height according to the direction of the movement.

4.3.4 When the flame control actuator is at the bottom of the lighter, and the lighter is held so that the user is facing the actuator, a clockwise movement shall produce a decrease in flame-height.

4.3.5 Adjustable utility lighters shall indicate the direction of movement to produce a higher or lower flame height. On utility lighters the direction of movement shall be permanently imprinted or engraved on the utility lighter. Such information shall be placed on the utility lighter in the vicinity of the flame-height adjustment feature and be readily visible and understandable.

4.4 *Spitting or Sputtering and Flaring*—Utility lighters, as defined in 3.1.14, when set at the maximum flame height, shall exhibit no spitting or sputtering as defined in 3.1.12 or flaring as defined in 3.1.3, when tested in accordance with 8.2.

4.5 *Flame Extinction:*

4.5.1 After a 10-s burn at maximum flame height, adjustable postmixing burner utility lighters, when extinguished in the intended manner, such as by releasing a button or lever, shall have any exposed flame completely extinguished within 3 s after such action is completed when tested in accordance with 8.3. In the case of postmixing burner utility lighters that have shields, an additional 3-s afterburn is acceptable if the flame height during this additional 3-s period does not extend above the shield.

4.5.2 After a 20-s burn, adjustable postmixing burner utility lighters, when set at a flame height of 100 mm (4 in.) or the maximum height the adjustment allows, if lower than 100 mm (4 in.), or nonadjustable postmixing burner utility lighters at their permanently set flame heights, when extinguished in the intended manner, such as by releasing a button or lever, shall have any exposed flame completely extinguished within 3 s after such action is completed when tested in accordance with 8.3. In the case of postmixing burner utility lighters that have shields, an additional 3-s afterburn is acceptable if the flame height during this additional 3-s period does not extend above the shield.

4.5.3 After a ~~20-s~~20-s burn, adjustable premixing burner utility lighters, when set at the maximum flame height, or nonadjustable premixing burner utility lighters at their permanently set flame heights, when extinguished in the intended manner, such as by releasing a button or lever, shall have any flame completely extinguished in no more than 6 s, when tested in accordance with 8.3.

NOTE 1—In the case of premixing burner utility lighters, a total afterburn of 6-s in this specification will be reconsidered periodically with a view to gradual reduction in line with technological progress.

4.5.4 Dual flame type utility lighters, as defined in 3.1.14.3, for each type of flame, the extinguish time shall comply with the corresponding requirement for that type of utility lighter and flame provided in 4.5.

4.5.5 Multiple flame type utility lighters, as defined in 3.1.14.4, for each flame, the extinguish time shall comply with the corresponding requirements for that type of utility lighter and flame provided in 4.5

4.6 *Volumetric Displacement*—For utility lighters shipped with fuel, the liquid portion of the fuel shall not exceed 85 % of the volumetric capacity of the fuel chamber when tested in accordance with 8.11.

5. Structural Integrity Requirements (Table 1)

5.1 Utility lighters shall have structural integrity as specified in requirements 5.2 – 5.9 (see Table 1A2.1).

5.2 Drop Test:

5.2.1 Utility lighters, as defined in 3.1.14, shall be capable of withstanding three separate 1.5-m (5-ft) drops conducted in accordance with 8.4 without fuel reservoir fragmentation, without sustained self-ignition as defined in 3.1.11, without a leakage rate exceeding 15 mg/min, and without impairing the subsequent safe operation of the utility lighter.

5.2.2 Utility lighters that meet the requirements of 5.2.1 and that are able to be ignited in the intended manner shall subsequently meet all the applicable requirements of 4.1 – 4.5, inclusive.

5.2.3 Utility lighters that are not able to be ignited in the intended manner do not constitute a failure.

5.3 *Temperature Test*—Utility lighters shall be capable of withstanding a temperature of 65°C (150°F) for 4 h when tested in accordance with 8.5.

5.3.1 Utility lighters that meet the requirements of 5.3 and that are able to be ignited in the intended manner after stabilization at $23\pm 2^{\circ}\text{C}$ ($73\pm 4^{\circ}\text{F}$) shall subsequently meet all the applicable requirements of 4.1 – 4.5, inclusive.

5.4 *Burning Test*—Adjustable utility lighters with the flame height set at maximum or nonadjustable utility lighters at their permanently set flame heights shall be capable of withstanding a burning time of 10 s in two different attitudes: (1) with the flame directed vertically upward, and (2) with the flame directed 45° below horizontal.

5.4.1 Test the utility lighter with the flame directed vertically upward. The utility lighter shall be capable of withstanding a total burning time of 10 s without evidence of any burning or distortion of components so as to cause a hazardous condition.

5.4.2 Utility lighters that meet the requirements of 5.4.1 and that are able to be ignited in the intended manner after stabilization of 5 min at $23\pm 2^{\circ}\text{C}$ ($73\pm 4^{\circ}\text{F}$) shall be tested in the same manner with the flame directed $45^{\circ} \pm 5^{\circ}$ below horizontal (see Fig. 13) without evidence of any burning or distortion of components so as to cause a hazardous condition.

5.5 *Continuous Burn*—Adjustable postmixing burner utility lighters with the flame height set at 75 mm (3 in.) or the maximum flame height the adjustment allows, if lower than 75 mm (3 in.); adjustable premixing burner utility lighters set at 60 mm (2.4 in.) or the maximum flame height the adjustment allows, if lower than 60 mm (2.4 in.); or nonadjustable utility lighters at their permanently set flame heights shall be capable of withstanding a continuous burning time of ~~2-min~~ 2 min with the flame in the 45° below horizontal attitude without causing a hazardous condition and when tested in accordance with 8.6: (see Fig. 3).

5.6 *Cycling Burn*—Adjustable postmixing burner utility lighters with the flame set at 75 mm (3 in.) or the maximum flame height the adjustment allows, if lower than 75 mm (3 in.); adjustable premixing burner utility lighters set at 60 mm (2.4 in.) or the maximum flame height the adjustment allows, if lower than 60 mm (2.4 in.); or nonadjustable utility lighters at their permanently set flame heights shall be capable of withstanding a burning time of 20 s, repeated 10 times, in the 45° below horizontal attitude and when tested in accordance with 8.7. Utility lighters able to be ignited in the intended manner shall subsequently meet all the applicable requirements of 4.1 – 4.5, inclusive. Any utility lighter that cannot make a flame shall not be classified as a failure. [is.iteh.ai/catalog/standards/sist/f277d29e-070b-432f-9fd0-18e8526eeb79/astm-f2201-19](https://www.astm.org/standards/sist/f277d29e-070b-432f-9fd0-18e8526eeb79/astm-f2201-19)

5.7 *External Finish*—Utility lighters shall have no external sharp edges that could cause accidental cuts or abrasions to the user when handled or used in the intended manner. Test for sharp edges in accordance with UL 1439.

5.8 *Compatibility*—Components of utility lighters, as defined in 3.1.14, that come in contact with the fuel supplied with the utility lighter or recommended by the manufacturer shall not deteriorate after exposure to the fuel so as to cause the utility lighter to fail any of the criteria contained in this specification or to allow a leakage rate exceeding 15 mg/min when tested in accordance with 8.8. Utility lighters able to be ignited in the intended manner shall subsequently meet all the applicable requirements of 4.1 – 4.5, inclusive.

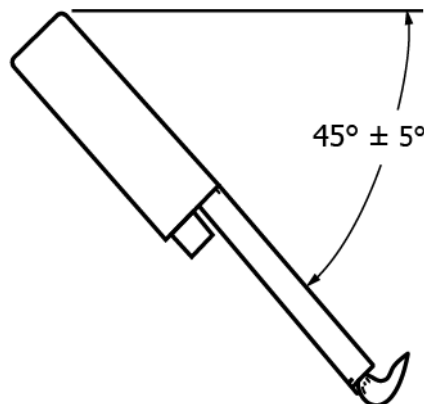

FIG. 3 Position of Specimen for the Burning Test Described in 5.4.2

5.9 *Pressure Tests*—Utility lighter fuel reservoirs shall be capable of withstanding an internal pressure of two times the vapor pressure occurring at 55°C (131°F) of the fuel recommended by the manufacturer when tested in accordance with 8.9.

6. Refilling of Utility Lighters

6.1 Refillable utility lighters, as defined in ~~3.1.14.43.1.14.6~~, shall ~~include~~ be accompanied with specific instructions and warnings as applicable in accordance with Section 7.

6.2 The refilling valve in a refillable utility lighter shall be secure enough so as not to allow a leakage rate of gas exceeding 15 mg/min when tested in accordance with 8.10.

7. Instructions and Warnings

7.1 All utility lighters shall be accompanied by the appropriate safety information (instructions, warnings, or both) communicating the proper method of use.

7.1.1 All utility lighters are subject to the labeling requirements found at 16 CFR Part 1500 and issued pursuant to 15 USC Section 1261 of the Federal Hazardous Substances Act.

7.2 Except as set forth in 7.3, this safety information shall be either on the utility lighters themselves, on a separate brochure or pamphlet packaged with the utility lighters, or on the product packaging at the point of sale. The format for this information should emphasize the warnings that are most appropriate to the type of utility lighter. This safety information shall be conspicuously placed with contrasting background color, type size, or style that makes it distinct from other information.

7.3 For all utility lighters, the specific signal word “DANGER” shall appear on the principal display panel of the product packaging and on the utility lighter itself, followed by the substance of the following: “Extremely Flammable. Contents Under Pressure.”

7.4 For all utility lighters, additional safety information shall be accompanied by the specific signal word “WARNING” in close proximity to the safety information.

7.5 For all utility lighters, the safety information shall contain the following statements:

7.5.1 “KEEP AWAY FROM CHILDREN” or “KEEP OUT OF REACH OF CHILDREN.” (The statement used shall be emphasized and distinctive.)

7.5.2 Ignite utility lighter away from face and clothing.

7.5.3 Do not use to light cigarettes, cigars, or pipes.

7.6 For all utility lighters, the safety information shall include the substance of the following as appropriate to the type of utility lighter:

7.6.1 Be sure flame is out after use.

7.6.2 Never expose to heat above 50°C (122°F) or to prolonged sunlight.

7.6.3 Never puncture or put in fire.

7.6.4 Extreme heat is present above the visible flame. Extra care should be taken to prevent burn, injury, or fire. (This statement shall accompany all premixing burner utility lighters.)

7.6.5 Follow all instructions and warnings provided by manufacturer of appliance or any other item when using this product.

7.6.6 Do not keep lit for more than 30 s.

7.6.7 Wait 2 min after refilling before using the utility lighter. (This statement shall accompany all refillable utility lighters.)

7.6.8 Contains flammable gas under pressure.

7.6.9 When filled, will contain flammable gas under pressure.

7.7 *Refilling Instructions for Utility Lighters*—Refillable utility lighters, as defined in ~~3.1.14.43.1.14.6~~, shall be accompanied by specific instructions as to the correct procedure to accomplish the refill operation. These instructions shall include the fuel recommended by the manufacturer and the appropriate information to ensure the proper mating between the refill container and the fuel reservoir of the utility lighter.

8. Test Methods

SAFETY STATEMENT—Persons using this consumer safety specification should be familiar with normal laboratory practices, if applicable. This consumer safety specification does not purport to address all possible safety concerns, if any, associate with the use of this standard. It is the responsibility of the user/tester to establish appropriate safety and health practices and to ensure compliance with any regulatory requirements.

8.1 *Test Method for Flame Height Measurement:*

8.1.1 *Scope*—The purpose of this procedure is to define the method of measurement of utility lighter flame height.

8.1.2 *Apparatus*—A nonflammable board scribed in 5-mm (0.25-in.) increments. The board should be fitted with a standoff at the base point that positions the utility lighter at least 25 mm (1 in.) from the board. The board can be supported vertically by any convenient means and tests conducted inside a draft-free chamber constructed from suitable nonflammable materials.