



Designation: ~~D7646 – 10 (Reapproved 2014)~~ **D7646 – 10 (Reapproved 2019)**

Standard Test Method for Determination of Cooling Characteristics of Aqueous Polymer Quenchants for Aluminum Alloys by Cooling Curve Analysis¹

This standard is issued under the fixed designation D7646; the number immediately following the designation indicates the year of original adoption or, in the case of revision, the year of last revision. A number in parentheses indicates the year of last reapproval. A superscript epsilon (ϵ) indicates an editorial change since the last revision or reapproval.

1. Scope

1.1 This test method covers the description of the equipment and the procedure for evaluating quenching characteristics of aqueous polymer quenchants by cooling rate determination.

1.2 This test method is designed to evaluate aqueous polymer quenchants for aluminum alloys in a non-agitated system. There is no correlation between these test results and the results obtained in agitated systems.

1.3 The values stated in SI units are to be regarded as standard. No other units of measurement are included in this standard.

1.4 *This standard does not purport to address all of the safety concerns, if any, associated with its use. It is the responsibility of the user of this standard to establish appropriate safety, health, and environmental practices and determine the applicability of regulatory limitations prior to use.*

1.5 *This international standard was developed in accordance with internationally recognized principles on standardization established in the Decision on Principles for the Development of International Standards, Guides and Recommendations issued by the World Trade Organization Technical Barriers to Trade (TBT) Committee.*

2. Referenced Documents

2.1 *ASTM Standards:*²

[D6200 Test Method for Determination of Cooling Characteristics of Quench Oils by Cooling Curve Analysis](#)

[E220 Test Method for Calibration of Thermocouples By Comparison Techniques](#)

[E230 Specification for Temperature-Electromotive Force \(emf\) Tables for Standardized Thermocouples](#)

2.2 *ISO Standards:*³

[ISO 3819 Laboratory Glassware—Beakers](#)

2.3 *Japanese Industrial Standards:*⁴

[JIS K 2242 Heat Treating Oil](#)

2.4 *Wolfson Engineering Group Specification:*⁵

[Laboratory Tests for Assessing the Cooling Curve of Industrial Quenching Media](#)

3. Terminology

3.1 *Definitions of Terms Specific to This Standard:*

3.1.1 *aqueous polymer quenchant, n*—aqueous solution containing a water soluble polymer; typically including poly(alkylene glycol), poly(ethyl oxazoline), poly(sodium acrylate) and poly(vinyl pyrrolidone). The quenchant solution also typically contains additives for corrosion and foam control, if needed. Quench severity of aqueous polymer quenchants is dependent on concentration and molecular weight of the specific polymer being evaluated, quenchant temperature, and agitation rate.

¹ This test method is under the jurisdiction of ASTM Committee D02 on Petroleum Products, Liquid Fuels, and Lubricants and is the direct responsibility of Subcommittee D02.L0.06 on Non-Lubricating Process Fluids.

Current edition approved Dec. 1, 2014/May 1, 2019. Published February 2015/July 2019. Originally approved in 2010. Last previous edition approved in 2014 as ~~D7646 – 10~~ D7646 – 10 (2014). DOI:10.1520/D7646-10R14; DOI:10.1520/D7646-10R19.

² For referenced ASTM standards, visit the ASTM website, www.astm.org, or contact ASTM Customer Service at service@astm.org. For *Annual Book of ASTM Standards* volume information, refer to the standard's Document Summary page on the ASTM website.

³ Available from Society of Automotive Engineers, International, SAE International (SAE), 400 Commonwealth Dr., Warrendale, PA 15096-0001, 15096, <http://www.sae.org>.

⁴ Available from Japanese Standards Association, 4-1-24, Akasaka Minato-ku, Tokyo 107-8440, Japan Association (JSA), Mita MT Bldg., 3-13-12 Mita, Minato-ku, Tokyo 108-0073, Japan, <http://www.jsa.or.jp>.

⁵ Available from Wolfson Heat Treatment Centre, Aston University, Aston Triangle, Birmingham B4 7ET, England, <http://www.sea.org.uk/whtc/>.

3.1.2 *characteristic temperature, n*—transition temperature from vapor blanket phase (film boiling phase) to rapid cooling phase (nucleate boiling phase) on cooling curve.

3.1.3 *cooling curve, n*—cooling curve is a graphical representation of the cooling time (t)–temperature (T) response of the probe (see 7.3). An example is illustrated in Part B of Fig. 1.

3.1.4 *cooling curve analysis, n*—the process of quantifying the cooling characteristics of a heat treating oil based on the temperature versus time profile obtained by cooling a pre-heated metal probe assembly (see Fig. 2) under standard conditions.

3.1.5 *cooling rate curve, n*—The cooling rate curve is obtained by calculating the first derivative (dT/dt) of the cooling time–temperature curve. An example is illustrated in Part B of Fig. 1.

3.1.6 *quench severity, n*—the ability of a quenching medium to extract heat from a hot metal.

3.1.7 *quenchant, n*—any medium, liquid, or gas that may be used to mediate heat transfer during the cooling of hot metal.

4. Summary of Test Method

4.1 Determine the silver rod probe assembly’s cooling time versus temperature after placing the assembly in a furnace and heating to 500°C and then quenching in an aqueous polymer quenchant solution. The temperature inside the probe assembly and the cooling times are recorded at selected time intervals to establish a cooling temperature versus time curve. The resulting cooling curve may be used to evaluate quench severity.

5. Significance and Use

5.1 This test method provides a cooling time versus temperature pathway. The results obtained by this test method may be used as a guide in quenchant selection or comparison of quench severities of different quenchants, new or used.

6. Interferences

6.1 The presence of contaminants, such as oil, salt, metal-working fluids, forging lubricants, and polymer degradation, may affect cooling curve results obtained by this test method for aqueous polymer quenchants.

7. Apparatus

7.1 *Furnace*—Use a horizontal or vertical electrical resistance tube-type furnace capable of maintaining a constant minimum temperature of 850°C over a heated length of not less than 120 mm and a probe positioned in the center of the heating chamber. The furnace shall be capable of maintaining the probe’s temperature within 62.5°C over the specimen length. The furnace, that is, the radiant tube heating media, shall be used with ambient atmosphere.

NOTE 1—Although the probe temperature is significantly lower 500°C than the recommended furnace temperature capability 850°C, this higher temperature capability is recommended since the same apparatus may be used for cooling curve analysis for steel alloys which is performed at 805°C to 815°C.

7.2 *Measurement System*—The temperature–time measurement system shall be a computer based data acquisition system capable of providing a permanent record of the cooling characteristics of each oil sample tested, producing a record of variation in the test probe assembly of temperature with respect to time, and cooling rate with respect to temperature.

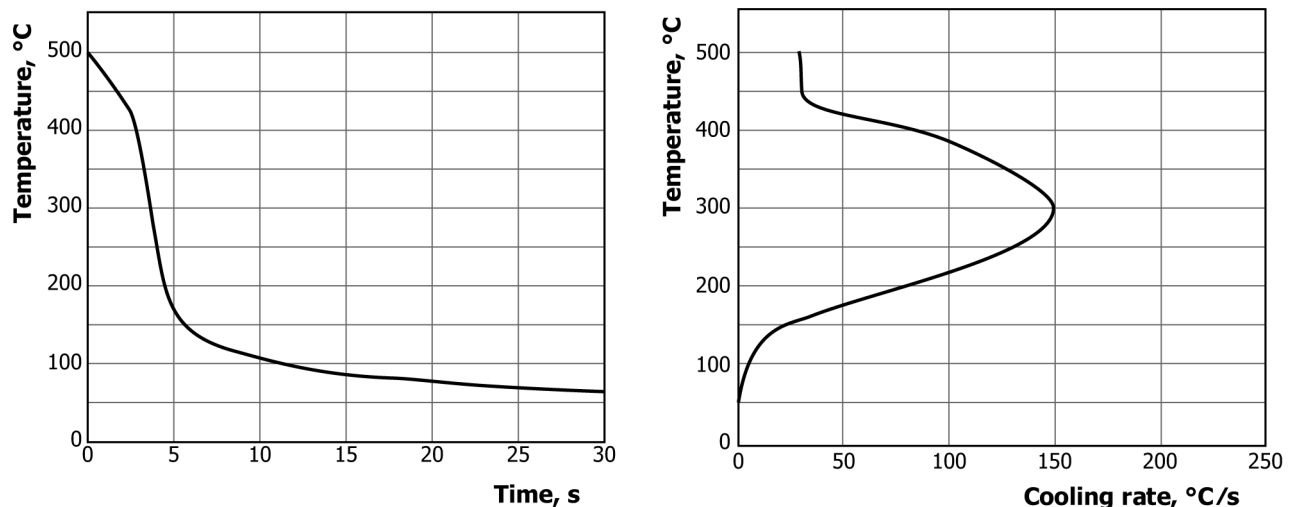

FIG. 1 Typical Temperature/Time and Temperature/Cooling Rate Plots for Test Probe Cooled in an Aqueous Polymer Quenchant

Unit: mm

Unit: mm

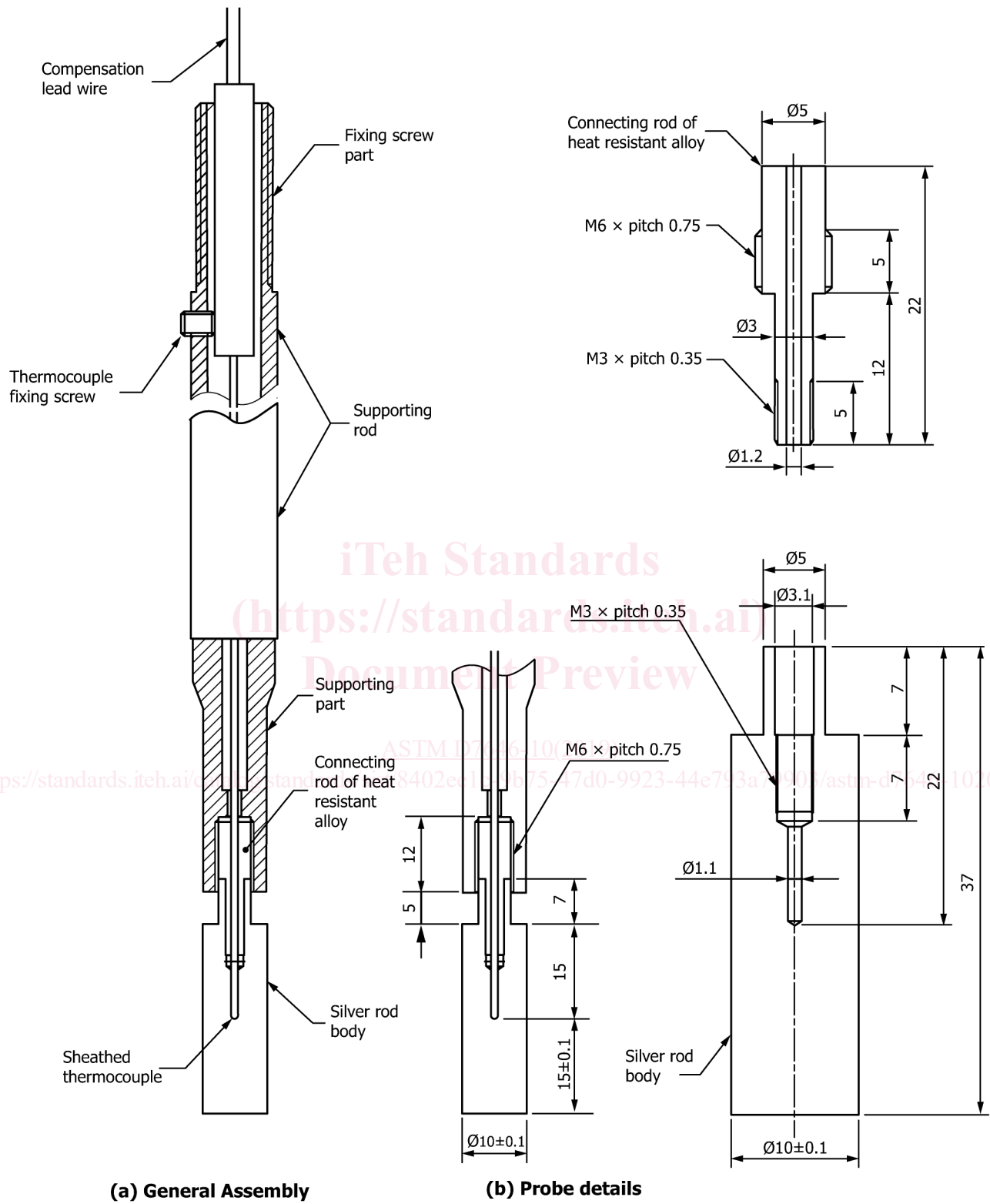

FIG. 2 Probe Details and General Probe Assembly

7.3 Probe—Shall be cylindrical, having a diameter of $\text{Ø}10 \text{ mm} \pm 0.1 \text{ mm} \pm 0.1 \text{ mm}$ and a length of $3030 \text{ mm} \pm 0.1 \text{ mm} \pm 0.1 \text{ mm}$ with a $\text{Ø}1.0 \text{ mm} \pm 0.1 \text{ mm}$ sheathed Type K thermocouple in its geometric center. The probe shall be made of a silver of purity