



Standard Test Method for Determining Fire Resistance of Perimeter Fire Barriers Using Intermediate-Scale, Multi-story Test Apparatus¹

This standard is issued under the fixed designation E2307; the number immediately following the designation indicates the year of original adoption or, in the case of revision, the year of last revision. A number in parentheses indicates the year of last reapproval. A superscript epsilon (ϵ) indicates an editorial change since the last revision or reapproval.

^{ε1} NOTE—The title and address for Reference GA-600 were updated editorially in November 2016.

INTRODUCTION

A perimeter fire barrier is the perimeter joint protection that provides fire resistance to prevent passage of fire from floor to floor within the building at the opening between the exterior wall assembly and the floor assembly. A perimeter fire barrier is a unique building construction detail not addressed by other fire test methods.

Among its other functions, a perimeter fire barrier impedes the vertical spread of fire from the floor of origin to the floor(s) above, at the building's exterior perimeter and accommodates various movements such as those induced by thermal differentials, seismicity, and wind loads.

This test method describes criteria and test methods used to determine the fire resistance of perimeter fire barriers when subjected to standard fire exposure conditions using the intermediate-scale, multistory test apparatus (ISMA). The use of the multi-story test apparatus and this test method are intended to simulate a possible fire exposure on a perimeter fire barrier.

1. Scope

1.1 This test method measures the performance of the perimeter fire barrier and its ability to maintain a seal to prevent fire spread during the deflection and deformation of the exterior wall assembly and floor assembly during the fire test, while resisting fire exposure from an interior compartment fire as well as from the flame plume emitted from the window burner below. The end point of the fire-resistance test is the period of time elapsing before the first condition of compliance is reached as the perimeter fire barrier is subjected to a time-temperature fire exposure. <https://standards.iteh.ai>

1.2 The fire exposure conditions used are those specified by this test method for the first 30 min of exposure and then conform to the Test Methods **E119** time-temperature curve for the remainder of the test in the test room.

1.3 This test method specifies the heating conditions, methods of test, and criteria for evaluation of the ability of a perimeter fire barrier to maintain the fire resistance where a floor and exterior wall assembly are juxtaposed to a perimeter joint.

1.4 Test results establish the performance of perimeter fire barriers during the fire-exposure period and shall not be construed as having determined the suitability of perimeter fire barriers for use after that exposure.

1.5 This test method does not provide quantitative information about the perimeter fire barrier relative to the rate of leakage of smoke or gases or both. While it requires that such phenomena be noted and reported when describing the general behavior of perimeter fire barrier during the fire-resistance test, such phenomena are not part of the conditions of compliance.

1.6 Potentially important factors and fire characteristics not addressed by this test method include, but are not limited to:

1.6.1 The performance of the perimeter fire barrier constructed with components other than those tested, and

1.6.2 The cyclic movement capabilities of perimeter fire barriers other than the cycling conditions tested.

1.7 This test method is used to measure and describe the response of materials, products or assemblies to heat and flame under controlled conditions but does not by itself incorporate all factors required for the fire-hazard or fire-risk assessment of the materials, products, or assemblies under actual fire conditions.

¹ This test method is under the jurisdiction of ASTM Committee **E05** on Fire Standards and is the direct responsibility of Subcommittee **E05.11** on Fire Resistance. Current edition approved Oct. 1, 2015. Published November 2015/July 2019. Originally approved in 2004. Last previous edition approved in 2015 as **E2307 – 15b**^{ε1} **E2307 – 15a**. DOI: [10.1520/E2307-15B](https://doi.org/10.1520/E2307-15B) [10.1520/E2307-19](https://doi.org/10.1520/E2307-19).

1.8 The values stated in inch-pound units are to be regarded as standard. The values given in parentheses are mathematical conversions to SI units that are provided for information only and are not considered standard.

1.9 The text of this test method references notes and footnotes which provide explanatory material. These notes and footnotes (excluding those in tables and figures) shall not be considered as requirements of the standard.

1.10 *This standard does not purport to address all of the safety concerns, if any, associated with its use. It is the responsibility of the user of this standard to establish appropriate safety, health, and environmental practices and determine the applicability of regulatory limitations prior to use.*

1.11 *This international standard was developed in accordance with internationally recognized principles on standardization established in the Decision on Principles for the Development of International Standards, Guides and Recommendations issued by the World Trade Organization Technical Barriers to Trade (TBT) Committee.*

2. Referenced Documents

2.1 ASTM Standards:²

[E84 Test Method for Surface Burning Characteristics of Building Materials](#)

[E108 Test Methods for Fire Tests of Roof Coverings](#)

[E119 Test Methods for Fire Tests of Building Construction and Materials](#)

[E176 Terminology of Fire Standards](#)

[E511 Test Method for Measuring Heat Flux Using a Copper-Constantan Circular Foil, Heat-Flux Transducer](#)

[E631 Terminology of Building Constructions](#)

[E1529 Test Methods for Determining Effects of Large Hydrocarbon Pool Fires on Structural Members and Assemblies](#)

[E1966 Test Method for Fire-Resistive Joint Systems](#)

2.2 Other Documents:

[Uniform Building Code Standard No. 26-9 Method of Test for the Evaluation of Flammability Characteristics of Exterior, Non-Loadbearing Wall Assemblies Containing Combustible Components Using the Intermediate-Scale Multistory Test Apparatus³](#)

[NFPA 285 Standard Method of Test for the Evaluation of Flammability Characteristics of Exterior Non-Load-Bearing Wall Assemblies Containing Combustible Components Using the Intermediate-Scale, Multistory Test Apparatus⁴](#)

[GA-600-2015 Fire Resistance Design Manual, 21st Edition⁵](#)

3. Terminology

3.1 Terms defined in Terminology [E176](#) and [E631](#) shall prevail for fire standard and building terms not defined in this document.

3.2 Definitions:

3.2.1 *blockout, n*—a recess formed in the floor assembly to accommodate the installation of the perimeter joint protection, flush with the wearing surface of the floor assembly.

3.2.2 *curtain wall assembly, n*—either a rated or non-rated, nonbearing exterior wall assembly secured to and supported by the structural members of the building.

3.2.3 *exterior wall assembly, n*—a curtain wall or a loadbearing exterior wall that is either fire resistance rated or one that is not.

3.2.4 *floor assembly, n*—a fire resistance rated loadbearing horizontal separating element adjacent to and separate from the floor of the observation room.

3.2.4.1 Discussion—

Floor assemblies tested in accordance with Test Methods [E119](#) are required to be loadbearing.

3.2.5 *integrity, n*—the ability of a perimeter fire barrier, when exposed to fire from two sides, to prevent the passage of flame and hot gases through it and the occurrence of flames on its unexposed sides as determined by using a cotton pad.

3.2.6 *maximum joint width, n*—the widest opening of the perimeter joint as defined by the test sponsor.

3.2.7 *minimum joint width, n*—the narrowest opening of the perimeter joint as defined by the test sponsor.

3.2.8 *movement cycle, n*—the change between the minimum and the maximum joint widths.

3.2.9 *nominal joint width, n*—the specified opening of the perimeter joint as defined by the test sponsor that is selected for test purposes.

² For referenced ASTM standards, visit the ASTM website, www.astm.org, or contact ASTM Customer Service at service@astm.org. For *Annual Book of ASTM Standards* volume information, refer to the standard's Document Summary page on the ASTM website.

³ International Conference of Building Officials Inc., 5360 Workman Mill Rd., Whittier, CA 90601.

⁴ National Fire Protection Association, 1 Batterymarch Park, Quincy, MA 02269-9101.

⁵ Gypsum Association, 6525 Belcrest Road, Suite 480, Hyattsville, Maryland 20782.

3.2.10 *observation room, n*—the second-story room of the ISMA.

3.2.11 *perimeter fire barrier, n*—the perimeter joint protection that provides fire resistance to prevent the passage of fire from floor to floor within the building at the opening between the exterior wall assembly and the floor assembly. The boundaries are the edge of the floor assembly and the interior face of the exterior wall assembly in contact with the perimeter joint protection.

3.2.11.1 *Discussion*—

For the purpose of this standard, a knee wall is not to be considered as part of the exterior wall.

3.2.12 *perimeter joint, n*—the linear void located between a juxtaposed exterior wall assembly and floor assembly to accommodate various movements induced by thermal differentials, seismicity, wind loads, and misalignments of the floor and wall during construction.

3.2.13 *perimeter joint protection, n*—a fire-resistive joint system located between the exterior wall assembly and the floor assembly that fills the perimeter joint.

3.2.13.1 *Discussion*—

Fire-resistive joint system is defined in Test Method E1966.

3.2.14 *separating element, n*—a floor assembly or exterior wall assembly.

3.2.15 *splice, n*—the connection or junction within the length of a perimeter joint protection.

3.2.15.1 *Discussion*—

A splice is a result of the device or method used to connect or join multiple lengths of the perimeter joint protection.

1. Gas Supply Line (Ref. 6.3.3.3)
2. Concrete Slab (First Floor of Test Room) (Ref. 6.2.2)
3. Wall (Ref. 6.2.3)
4. Test Room Burner (Ref. 6.3.2)
5. Area of Burner with Holes (6.3.2.3)
6. Column (Typical) (Ref. 6.2.2)

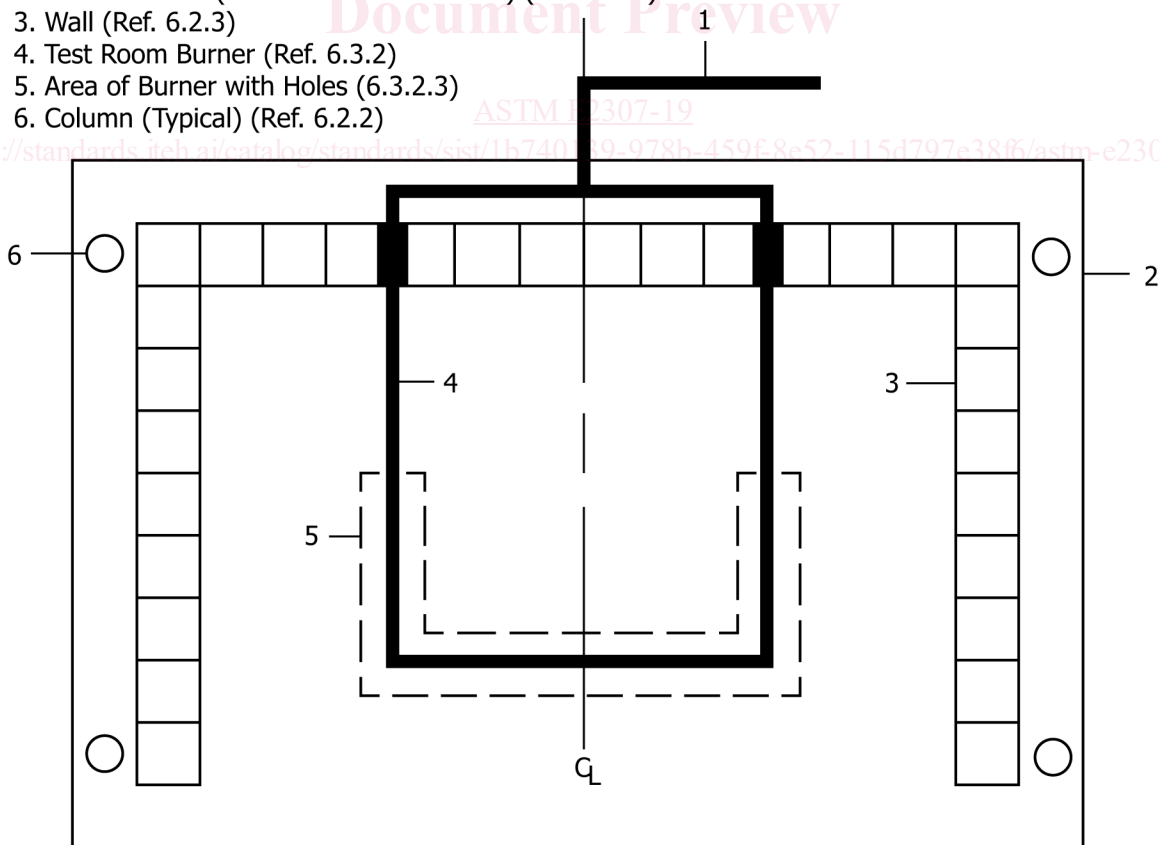

FIG. 1 Plan View of Test Room Burner Positioned in Test Room (See 6.3.2 for Dimensions)

- (1) Window Burner (see 6.3.3)
- (2) Slot in Burner (see 6.3.3.2)
- (3) Gas Supply Line (see 6.3.3.3)
- (4) Perimeter Joint Protection (see 3.2.13)
- (5) Window (see 7.3.9)
- (6) Test Room in Test Apparatus (see 3.2.18)
- (7) Observation Room in Test Apparatus (see 3.2.10)
- (8) Horizontal Centerline of Burner (see 6.3.3.5)
- (9) Vertical Centerline of Burner (see 6.3.3.5)
- (10) Window Burner Location During Test (see 6.3.3.5)
- (11) Exterior Wall Assembly or Calibration Wall (see 7.3 and 9.2)
- (12) Test Apparatus (ISMA) (see 6.2)
- (13) Floor Assembly (see 7.4)
- (14) Floor of Observation Room (see 6.2.4.2)
- (15) Roof Slab (see 6.2.2)
- (16) Floor of Test Room (see 6.2.2)
- (17) Window Sill Height (see 7.3.9.2)

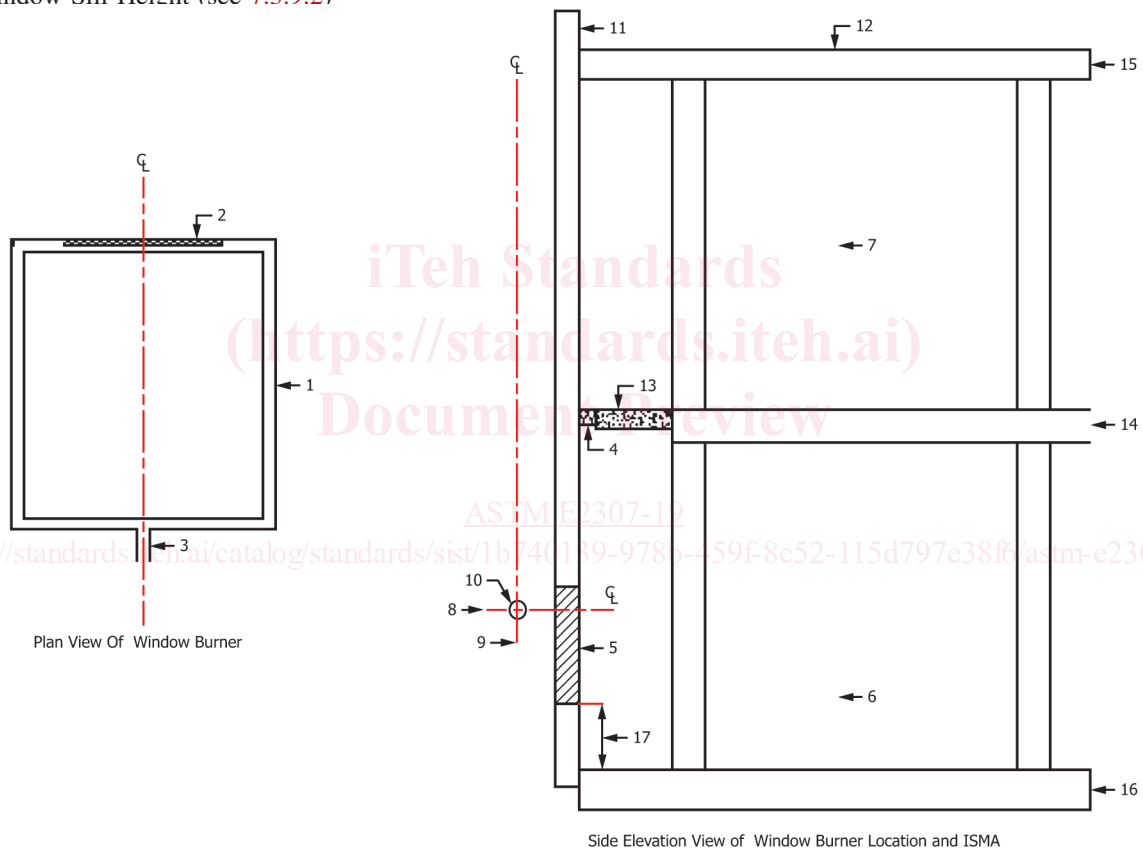

FIG. 2 Plan View of Window Burner and Side Elevation View of Window Burner Location

3.2.16 *supporting construction, n*—the arrangement of separating elements forming the intersection into which the perimeter joint protection is installed.

3.2.17 *test assembly, n*—the complete assembly of the test specimen together with the test apparatus.

3.2.18 *test room, n*—the first-story room of the ISMA.

3.2.19 *test specimen, n*—the specific test details of the perimeter fire barrier.

4. Summary of Test Method

4.1 This test method describes the following test sequence and procedure:

4.1.1 When the maximum joint width does not equal the minimum joint width, the perimeter fire barrier is movement cycled before being fire tested.

4.1.2 A perimeter joint protection and its supporting construction are conditioned and fire tested.

1. Exterior Wall Assembly or Calibration Wall (Ref. 7.3 and 9.2)
2. Window (Ref. 7.3.9)
3. Test Frame (Optional)

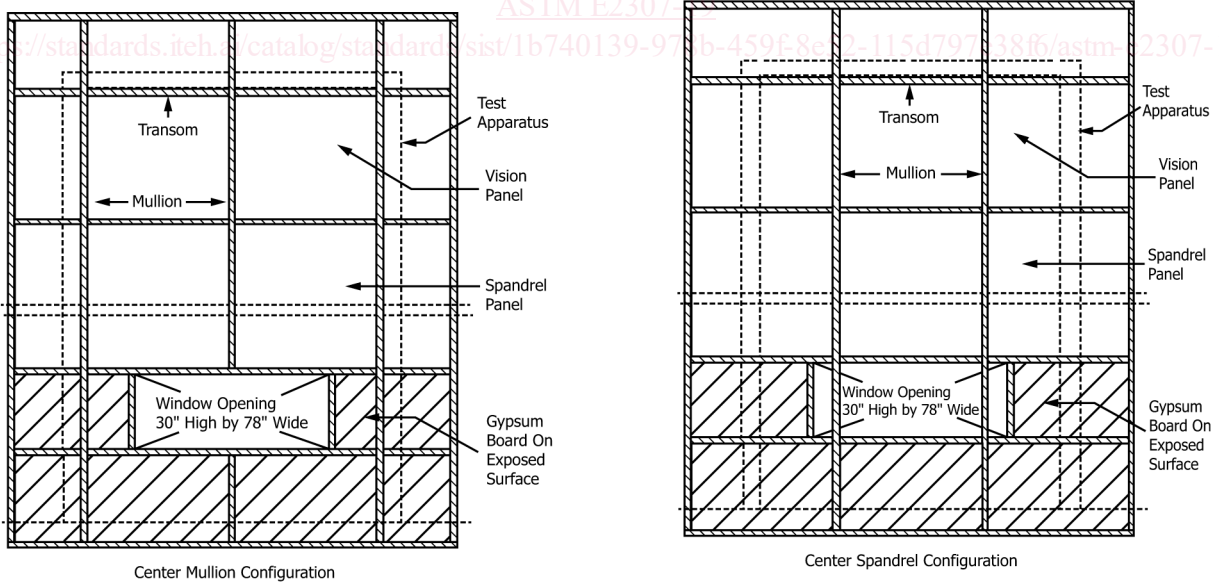
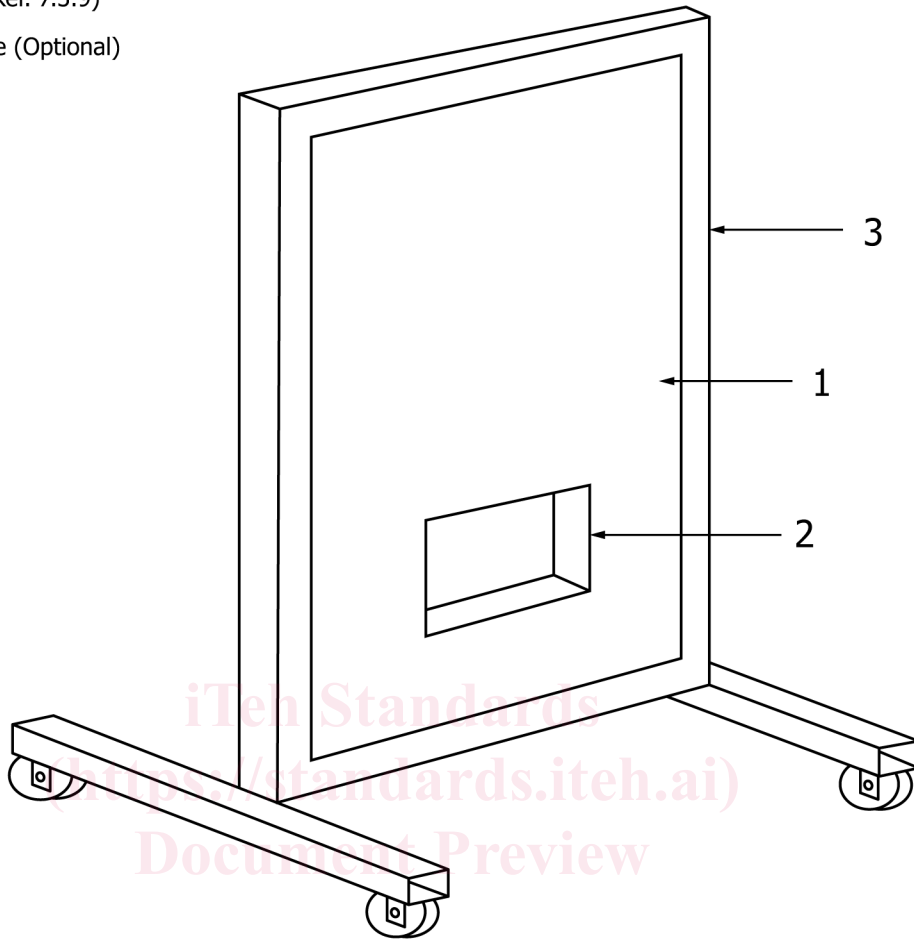
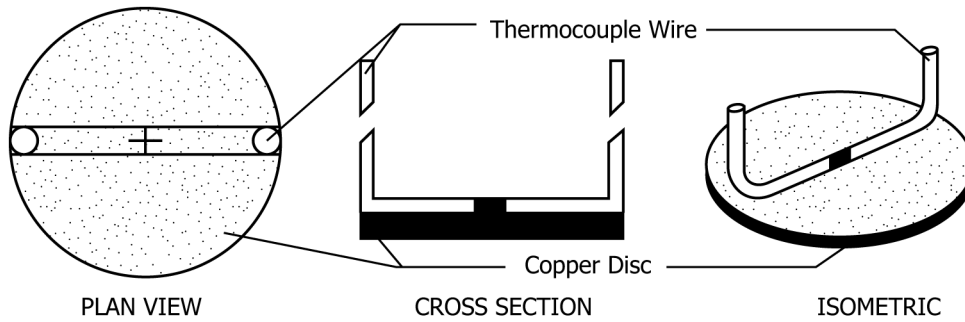
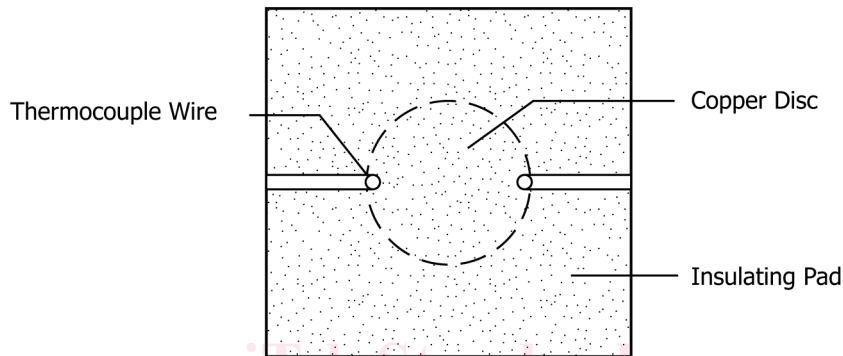

FIG. 3 Example of an Exterior Wall Assembly with Window Opening in a Test Frame (See 7.3.1)

4.1.3 During the fire test, the integrity of the perimeter joint protection and its supporting construction is determined by use of a cotton pad.



0.5 in (12 mm) Diameter \times 0.008 in (0.2 mm) thick
Copper Disc with 25 GA (0.5 mm dia.) Thermocouple Wire



1.2 \times 1.2 \times 0.08 in (30 \times 30 \times 2 mm) Insulating Pad
with cuts to all pad to be positioned over copper disc.

FIG. 4 Typical Copper Thermocouple Disc and Insulating Pipe (See 6.6 and 6.7)

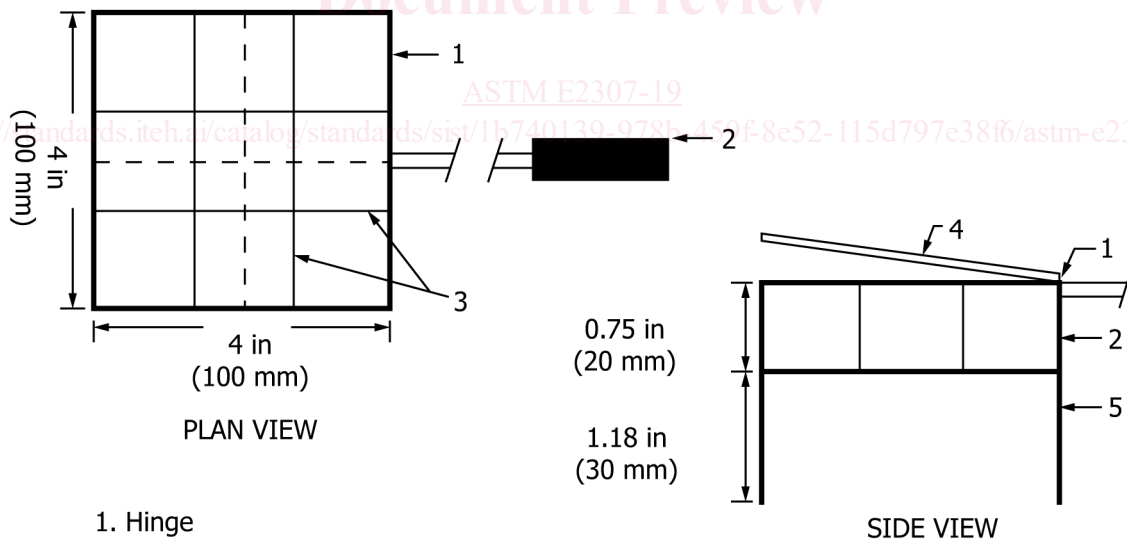

1. Hinge
2. Handle
3. 21 Gage (0.5 mm) Diameter Steel Wire
4. Hinged Lid with Latch
5. 16 Gage (1.31 mm) Diameter Steel Wire Framework

NOTE 1: Solid lines illustrate the framework.

NOTE 2: Dashed lines illustrate the hinged lid.

FIG. 5 Typical Cotton Wool Pad Holder (See 6.8.2)

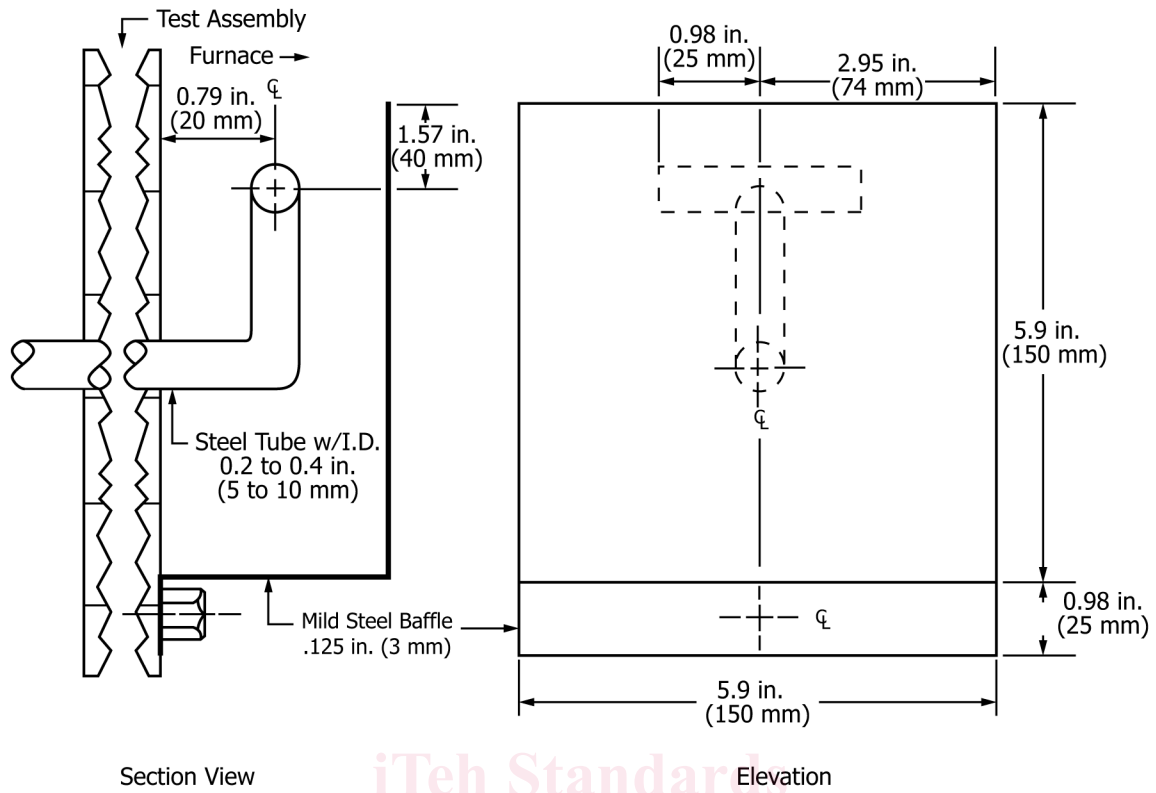
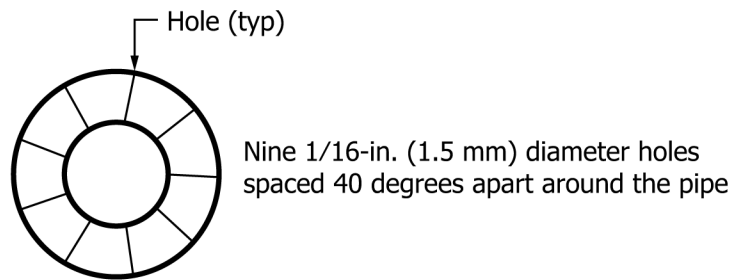
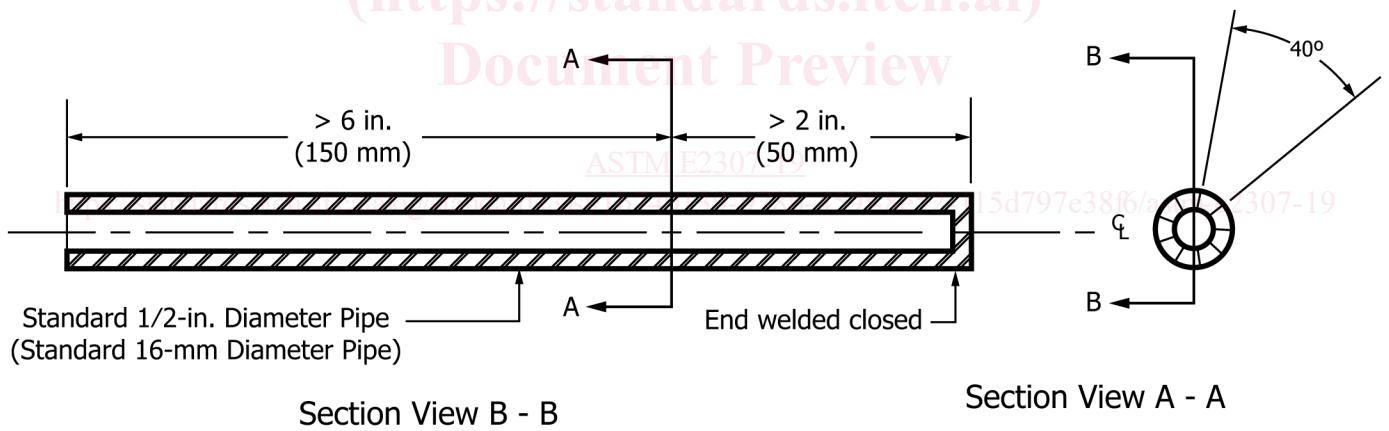

FIG. 6 T-Shaped Sensor (See 6.10.1.1)



Enlarged Section View A - A

FIG. 7 Tube Sensor (See 6.10.1.2)

1. Test Room Thermocouple Locations (Typical) (Ref. 8.1)
2. Floor of Test Room (Ref. 6.2.2)
3. Wall (Ref. 6.2.3)
4. Column (Typical) (Ref. 6.2.2)

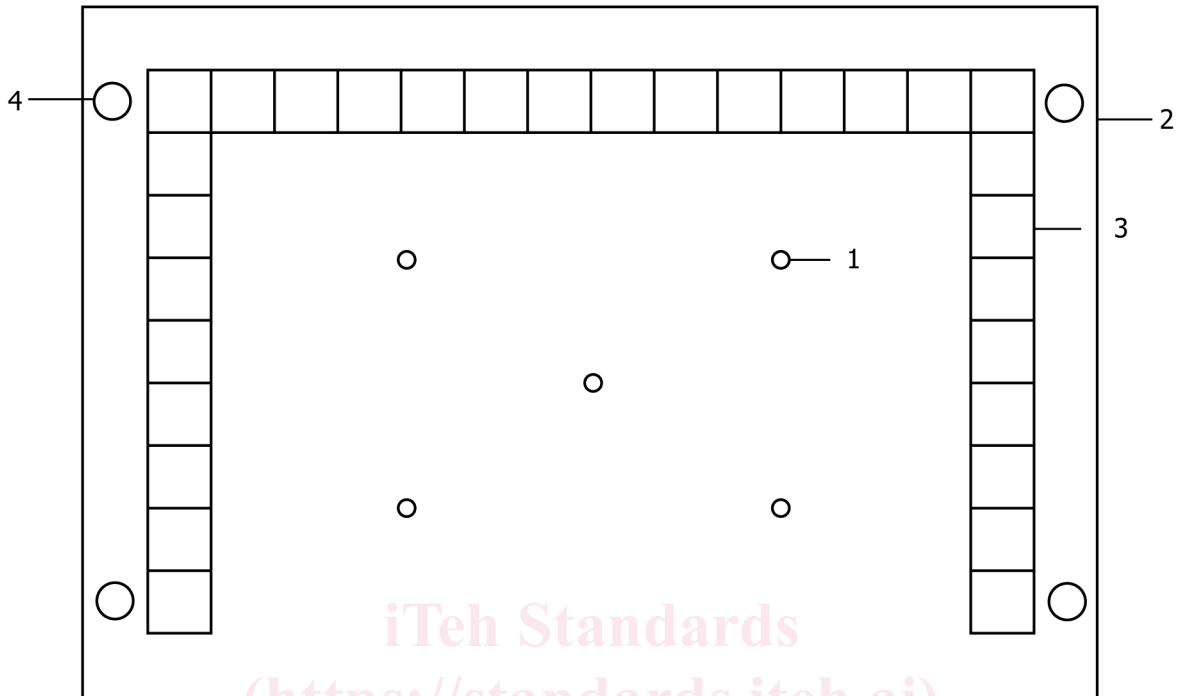

FIG. 8 Exposed Thermocouple Layout on Underside of Observation Room Floor in Test Room (See 8.1)

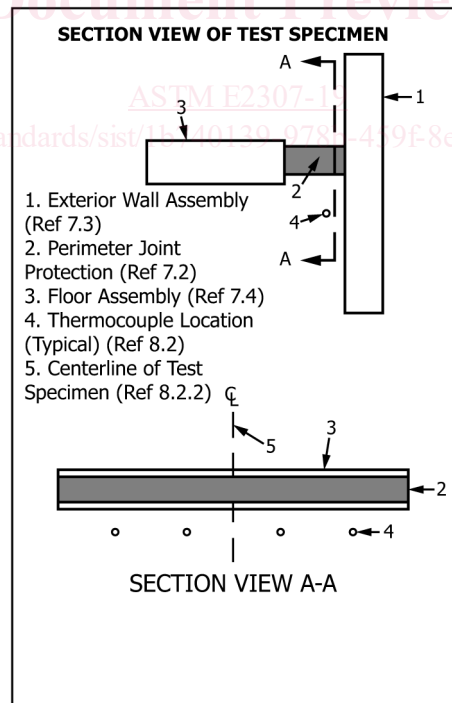

FIG. 9 Exposed Thermocouple Layout in Test Room (See 8.2)

5. Significance and Use

- 5.1 This test method provides for the following measurements and evaluations:
 - 5.1.1 Movement capacity of the perimeter fire barrier.

- 5.1.2 Loadbearing capacity of the perimeter joint protection is optional.
- 5.1.3 Ability of the perimeter fire barrier to resist the passage of flames and hot gases.
- 5.1.4 Transmission of heat through the perimeter fire barrier.

5.2 This test method does not provide the following:

5.2.1 Evaluation of the degree to which the perimeter fire barrier contributes to the fire hazard by generation of smoke, toxic gases, or other products of combustion,

5.2.2 Measurement of the degree of control or limitation of the passage of smoke or products of combustion through the perimeter fire barrier,

NOTE 1—This test method does not measure the quantity of smoke or hot gases through the floor assembly, the wall assembly, or the perimeter joint protection.

5.2.3 Measurement of flame spread over the surface of the perimeter fire barrier,

NOTE 2—The information in 5.2.1 through 5.2.3 are determined by other suitable fire test methods. For example, Test Method E84 is used to determine 5.2.3.

5.2.4 Durability of the test specimen under actual service conditions, including the effects of cycled temperature,

5.2.5 Effects of a load on the movement cycling of the perimeter fire barrier established by this test method,

5.2.6 Rotational, vertical, and horizontal shear capabilities of the test specimen,

5.2.7 Any other attributes of the test specimen, such as wear resistance, chemical resistance, air infiltration, water-tightness, and so forth, and

5.2.8 A measurement of the capability of the test specimen to resist:

5.2.8.1 Flame propagation over the exterior faces of the test specimen,

5.2.8.2 Spread of flame within the combustible core component of the exterior wall assembly from one story to the next,

NOTE 3—Some exterior wall assemblies are made from sandwich panels, which use EPS foam or other similar materials that are combustible.

5.2.8.3 Spread of flame over the interior surface (room side) of the test specimen from one story to the next, and

NOTE 4—While it is a failure to have fire on the interior surface of the observation room, this test method does not provide a measurement of that flame spread.

5.2.8.4 Lateral spread of flame from the compartment of fire origin to adjacent spaces.

NOTE 5—The exterior wall assembly, floor assembly, and perimeter joint protection are individual components. The capabilities of individual components are not part of this specific test method's Conditions of Compliance.

[ASTM E2307-19](https://standards.iteh.ai/catalog/standards/sist/1b740139-978b-459f-8e52-115d797e38f6/astm-e2307-19)

<https://standards.iteh.ai/catalog/standards/sist/1b740139-978b-459f-8e52-115d797e38f6/astm-e2307-19>

5.3 In this test method, the test specimens are subjected to one or more specific test conditions. When different test conditions are substituted or the end-use conditions are changed, it is not always possible by, or from, this test method to predict changes to the characteristics measured.

5.4 This test method is not intended to be used as the only test method in the selection of a perimeter fire barrier. It is not intended as a specification for all attributes required by a perimeter fire barrier, or any of its individual components, in order for a perimeter fire barrier to be used in a particular application.

6. Apparatus

6.1 The test apparatus described in 6.2 shall be located inside a test facility. The facility shall have provisions for supplying fresh combustion make-up air during the test. The facility shall be constructed to allow for the exhaust of the combustion by-products during the test, while not inducing airflow on the exterior face of the test specimen. The test facility shall protect the test apparatus and test specimen from weather conditions such as wind and rain.

6.2 Test Apparatus:

6.2.1 The ISMA consists of a two-story test structure consisting of a test room and observation room (See Fig. 2.). Each room in the test apparatus is square having inside length and width dimensions (unfinished and unprotected by any fire resistive materials) of 120 ± 0.5 in. (3048 ± 13 mm) and a height (unfinished and unprotected by any fire resistive materials) of 84 ± 0.5 in. (2134 ± 13 mm).

NOTE 6—The test apparatus is similar to the one used in U.B.C. Standard No. 26-9 and NFPA 285.

6.2.2 The floors and roof of the test apparatus shall be supported by columns and beams of a size that will support the load of the floor and roof. These supports shall be located outside of both the test room and the observation room. The floor of the observation room shall be 8 ± 0.5 in. (203 ± 13 mm) thick (See Fig. 8.).

6.2.3 The three permanent non-bearing walls that form each room of the test apparatus shall support the insulation defined in 6.2.4.1 during the entire fire-resistance test.

NOTE 7—Concrete block, 8 ± 0.5 in. (203 ± 13 mm) thick, has been found to be acceptable.

6.2.4 No insulation is required in the observation room; but the interior surfaces of the test room shall be insulated.

6.2.4.1 Insulate the interior face of the walls forming the test room with one layer of nominal 0.625-in. (15.9-mm) thick, Type X gypsum wallboard and one layer of nominal 1.5-in. (38-mm) thick ceramic fiber insulation, having a minimum density of 8 lb/ft^3 (128 kg/m^3), on the interior face. The maximum insulation thickness permitted on each face is 2.5 in. (64 mm). Insulate the underside of the floor of the observation room in the same manner, except the portion that is designated the “floor assembly,” which is adjacent to the perimeter joint protection, shall not be insulated (See Fig. 2 and 7.4.).

6.2.4.2 Insulate the floor of the test room with two layers of nominal 0.625-in. (15.9-mm) thick, Type X gypsum wallboard.

6.2.5 Each room shall have one access opening with a width and height of nominal 3.5 by 6.75 ft (1.07 by 2.06 m). The access opening of the test room shall be capable of being closed during tests while the access opening of the observation room shall remain open during tests.

6.2.5.1 Additional access openings are permitted in the observation room for instrumentation and video; however, they shall be closed during the test.

6.3 Burners:

6.3.1 The test apparatus in 6.2 shall be equipped with two gas-fired burners.

6.3.2 Test Room Burner:

6.3.2.1 Position the test room burner inside the test room. Construct the test room burner (See Fig. 1) as follows:

6.3.2.2 Use a nominal 2-in. (51-mm) OD steel pipe. The test room burner shall be rectangular shaped with its longitudinal axis at least 78.75 in. (2000 mm) long and its transverse axis at least 60 in. (1524 mm) wide. Extend 72 ± 1 in. (1829 ± 25 mm) of the test room burner into the test room.

6.3.2.3 Drill upward facing nominal diameter 0.125-in. (3.2-mm) holes in the pipe. Locate the holes in the front “U” shaped portion of the test room burner. Start holes at a nominal location of 42 in. (1066 mm) from the back wall on both sides of the gas supply pipes and continue across the front gas supply pipe. Place the holes nominally 1 in. (25 mm) on center.

NOTE 8—The holes drilled are nominal because they are made using a conventional $\frac{1}{8}$ -in. drill bit, therefore, their size is dependent upon the tolerances of the drill bit.

6.3.2.4 Support the test room burner so that it is level and its horizontal centerline is 30 ± 1 in. (762 ± 25 mm) above the floor of the test room.

6.3.2.5 Center the test room burner in the test room using Fig. 1 for reference.

6.3.2.6 Equip the test room burner with a gas supply line that is located outside the test apparatus. Wrap the entire gas supply pipe system with a single layer of nominal 1-in. (25-mm) thick ceramic fiber blanket, with a minimum density of 8 lb/ft^3 (128 kg/m^3).

6.3.3 Window Burner:

6.3.3.1 Construct the window burner (See Fig. 2) as follows: