



Designation: F1821 – 19

Standard Consumer Safety Specification for Toddler Beds¹

This standard is issued under the fixed designation F1821; the number immediately following the designation indicates the year of original adoption or, in the case of revision, the year of last revision. A number in parentheses indicates the year of last reapproval. A superscript epsilon (ϵ) indicates an editorial change since the last revision or reapproval.

INTRODUCTION

This consumer safety specification addresses toddler bed incidents that were identified by the Consumer Product Safety Commission (CPSC).

In response to incident data supplied by the commission, this consumer safety specification attempts to minimize: entrapment in bed end structures, entrapment between the guardrail and side rail, and entrapment in the mattress support system. Entrapment of a child's head or neck can result in asphyxiation. It also addresses corner post extensions, which may catch pacifier cords, ribbons, necklaces, or clothing that a child may be wearing and which may be caught on a projection.

This consumer safety specification is written in accordance with the current available state-of-the-art technology and will be updated whenever substantive information becomes available that necessitates additional requirements or justifies a revision to existing requirements.

1. Scope

1.1 This consumer safety specification covers requirements for the design and performance of toddler beds. It also contains requirements for labeling and instructional material.

1.2 This consumer safety specification is intended to minimize incidents to children resulting from normal use and reasonably foreseeable misuse of toddler beds. It does not address incidents resulting from alteration or unreasonable misuse.

1.3 For the purposes of this consumer safety specification, a toddler bed is a bed that is sized to accept a full-size crib mattress and is intended for use by a child not less than 15 months of age and who weighs no more than 50 lb (22.7 kg).

1.4 No toddler bed produced after the approval date of this consumer safety specification shall indicate compliance with this specification, either by label or by other means, unless it conforms to all the requirements contained herein.

1.5 This consumer safety specification includes the following sections:

Scope	Section 1
Referenced Documents	Section 2
Terminology	Section 3

Calibration and Standardization	Section 4
General Requirements	Section 5
Performance Requirement	Section 6
Test Methods	Section 7
Marking and Labeling	Section 8
Instructional Literature	Section 9
Keywords	Section 10

1.6 The values stated in inch-pound units are to be regarded as standard. The values given in parentheses are mathematical conversions to SI units that are provided for information only and are not considered standard.

1.7 The following safety hazards caveat pertains only to the test methods portion, Section 7, of this consumer safety specification: *This standard does not purport to address all of the safety concerns, if any, associated with its use. It is the responsibility of the user of this standard to establish appropriate safety, health, and environmental practices and determine the applicability of regulatory limitations prior to use.*

1.8 *This international standard was developed in accordance with internationally recognized principles on standardization established in the Decision on Principles for the Development of International Standards, Guides and Recommendations issued by the World Trade Organization Technical Barriers to Trade (TBT) Committee.*

2. Referenced Documents

2.1 *ASTM Standards:*²
D3359 Test Methods for Rating Adhesion by Tape Test

¹ This consumer safety specification is under the jurisdiction of ASTM Committee F15 on Consumer Products and is the direct responsibility of Subcommittee F15.18 on Cribs, Toddler Beds, Play Yards, Bassinets, Cradles and Baby Changing Products.

Current edition approved June 1, 2019. Published July 2019. Originally approved in 1997. Last previous edition approved in 2018 as F1821 – 18. DOI: 10.1520/F1821-19.

² For referenced ASTM standards, visit the ASTM website, www.astm.org, or contact ASTM Customer Service at service@astm.org. For *Annual Book of ASTM Standards* volume information, refer to the standard's Document Summary page on the ASTM website.

D3574 Test Methods for Flexible Cellular Materials—Slab, Bonded, and Molded Urethane Foams

F1169 Consumer Safety Specification for Full-Size Baby Cribs

2.2 *Code of Federal Regulations*:³

16 CFR 1303 Ban of Lead-Containing Paint and Certain Consumer Products Bearing Lead-Containing Paint

16 CFR 1500 Hazardous Substances Act Regulations, including the following sections:

16 CFR 1500.48 Technical Requirements for Determining a Sharp Point in Toys and Other Articles Intended for Children Under 8 Years of Age

16 CFR 1500.49 Technical Requirements for Determining a Sharp Metal or Glass Edge in Toys and Other Articles Intended for Children Under 8 Years of Age

16 CFR 1500 .50 -.53 Test Method for Simulating Use And Abuse of Toys and Other Articles Intended for Use By Children

16 CFR 1501 Method for Identifying Toys and Other Articles Intended for Use by Children Under 3 Years of Age Which Present Choking, Aspiration or Ingestion Hazards Because of Small Parts

3.1.9 *paper labels*, *n*—any label which tears without the aid of tools and leaves a fibrous edge.

3.1.10 *partially bounded openings*, *n*—any opening in a toddler bed that is not totally enclosed by boundaries on all sides so that the perimeter of the opening is discontinuous.

3.1.11 *permanent marking*, *n*—a marking or label that, during an attempt to remove it manually without the aid of tools or solvents, cannot be removed or tears upon removal, or such action damages the surface to which it is attached.

3.1.12 *removable guardrail*, *n*—a guardrail that can be removed without the use of tools.

3.1.13 *seam*, *v*—a means of joining fabric components, such as sewing, welding, heat sealing, or gluing.

3.1.14 *side rail*, *n*—the structure connecting the end structures.

3.1.15 *static load*, *adj*—a vertically downward force applied by a calibrated force gage or by dead weights.

3.1.16 *structural failure*, *n*—damage to a component(s) or assembly resulting in partial separation (greater than 0.040 in. (1.00 mm) over original configuration) or complete separation of the component(s) or assembly.

4. Calibration and Standardization

4.1 All testing shall be conducted on a concrete floor that may be covered with a 1/8-in. (3-mm) thick vinyl flooring cover, unless test instructs differently.

4.2 The product shall be completely assembled, unless otherwise noted, in accordance with the manufacturer's instructions.

4.3 No testing shall be conducted within 48 h of manufacturing.

4.4 The product to be tested shall be in a room with ambient temperature of 73 ± 9°F (23 ± 5°C) for at least 1 h prior to testing. Testing shall then be conducted within this temperature range.

4.5 All testing required by this consumer safety specification is to be conducted on the same unit.

5. General Requirements

5.1 The bed shall conform to the regulations specified in Section 2 of this specification before and after testing.

5.2 There shall be no hazardous sharp points or edges as defined by 16 CFR 1500.48 and 16 CFR 1500.49 before and after testing to this consumer safety specification.

5.3 There shall be no small parts as defined by 16 CFR 1501 before testing or liberated as a result of testing to this specification.

5.4 The paint and surface-coating on the product shall comply to 16 CFR 1303.

5.5 Prior to testing, any exposed wood parts shall be smooth and free from splinters.

5.6 *Scissoring, Shearing, and Pinching*—A toddler bed, when in the manufacturer's recommended use position, shall be designed and constructed to prevent injury to the occupant

3. Terminology

3.1 *Definitions of Terms Specific to This Standard*:

3.1.1 *bed*, *n*—for the purpose of this specification, a toddler bed, as described in 3.1.2.

3.1.2 *bed, toddler*, *n*—for the purpose of this specification, any bed sized to accommodate a full-size crib mattress having minimum dimensions of 51 5/8 in. (1310 mm) in length and 27 1/4 in. (690 mm) in width and is intended to provide free access and egress to a child not less than 15 months of age and who weighs no more than 50 pounds (22.7 kg).

3.1.3 *corner post*, *n*—vertical post located at the corner of a product.

3.1.4 *end structure*, *n*—an upright structure at the head or foot of a bed to which the side rails or mattress support system, or both, attach.

3.1.5 *guardrail*, *n*—of a bed, a rail attached to a bed intended to help prevent a sleeping occupant from rolling, sliding, or otherwise falling out of the long side of the bed.

3.1.6 *manufacturer's recommended use position*, *n*—any position that is presented as a normal, allowable, or acceptable configuration for the use of the product by the manufacturer in any descriptive or instructional literature. This specifically excludes positions that the manufacturer shows in a like manner in its literature to be unacceptable, unsafe, or not recommended.

3.1.7 *mattress support system*, *n*—those components of a bed structure that support the mattress.

3.1.8 *non-paper label*, *n*—any label material (such as plastic or metal) which either will not tear without the aid of tools, or tears, leaving a sharply defined edge.

³ Available from U.S. Government Printing Office Superintendent of Documents, 732 N. Capitol St., NW, Mail Stop: SDE, Washington, DC 20401.

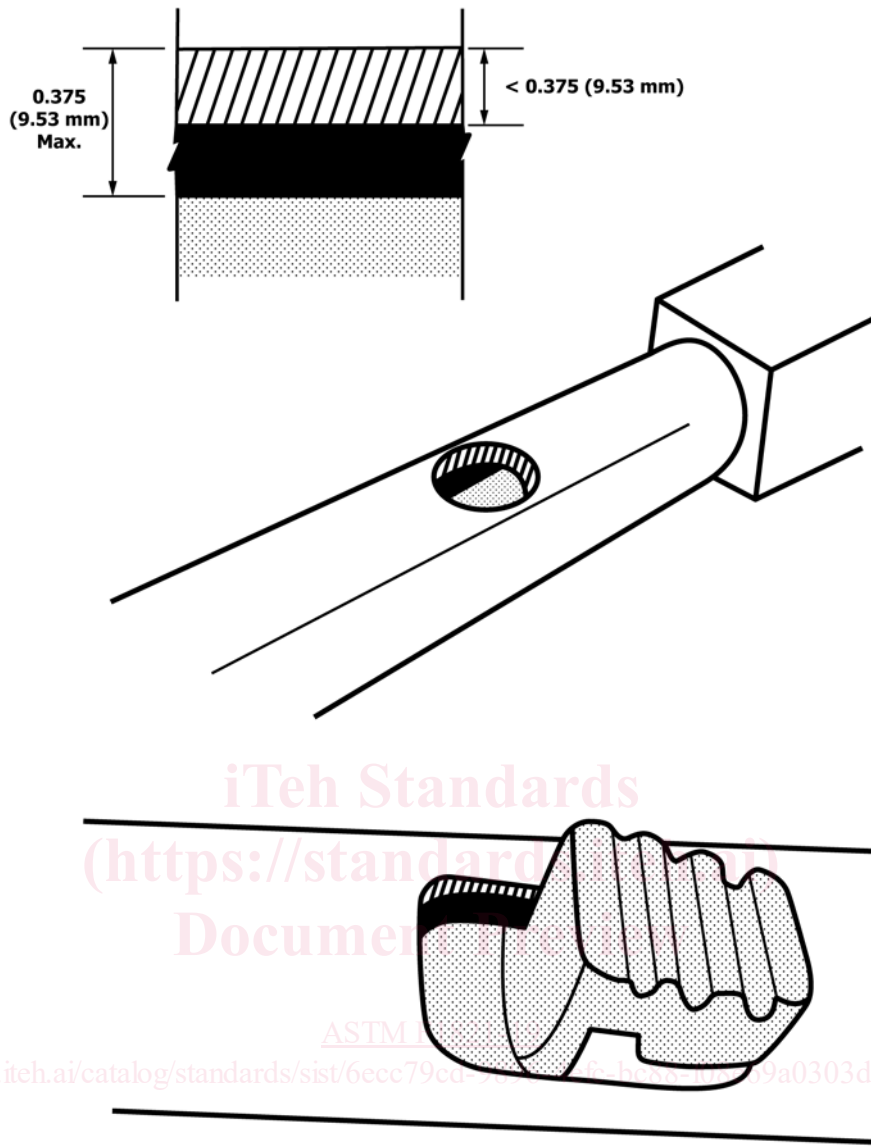

FIG. 1 Opening Example

from any scissoring, shearing, or pinching when members or components rotate about a common axis or fastening point, slide, pivot, fold or otherwise move relative to one another. Scissoring, shearing, or pinching that may cause injury shall not be permissible when the edges of any rigid parts admit a probe that is greater than 0.210-in. (5.33-mm) diameter and less than 0.375-in. (9.53-mm) diameter at any accessible point throughout the range of motion of such parts.

5.7 *Protective Components*—If a child can grasp components between the thumb and forefinger, or teeth, such as caps, sleeves, or plugs used for protection from sharp edges, points, or entrapment of fingers or toes, or if there is at least a 0.040-in. (1.00-mm) gap between the component and its adjacent parent component, such a component shall not be removed when tested in accordance with 7.7.

5.8 *Openings:*

5.8.1 *Finger Entrapment*—Holes or slots that extend entirely through a wall section of any rigid material less than

0.375-in. (9.53-mm) thick and admit a 0.210-in. (5.33-mm) diameter rod shall also admit a 0.375-in. (9.53-mm) diameter rod. Holes or slots that are between 0.210 and 0.375 in. (5.33 and 9.53 mm) and have a wall thickness less than 0.375 in. (9.53 mm) but are limited in depth to 0.375 in. (9.53 mm) maximum by another rigid surface shall be permissible (see Fig. 1). The product shall be evaluated in all manufacturer's recommended use positions.

5.8.2 *Torso Entrapment*—There shall be no openings in the mattress support system, headboard, footboard, guard rail, or any point where these components are joined together that will permit complete passage of the wedge block (see Fig. 2). The product shall be evaluated in all manufacturer's recommended use positions when tested in accordance with 6.3, 6.4, or 6.5.

5.9 *Labeling*—Warning labels (whether paper or non paper) shall be permanent when tested per 7.8. Warning statements applied directly onto a surface of the product by hot stamping, heat transfer, printing, wood burning, etc. shall be permanent

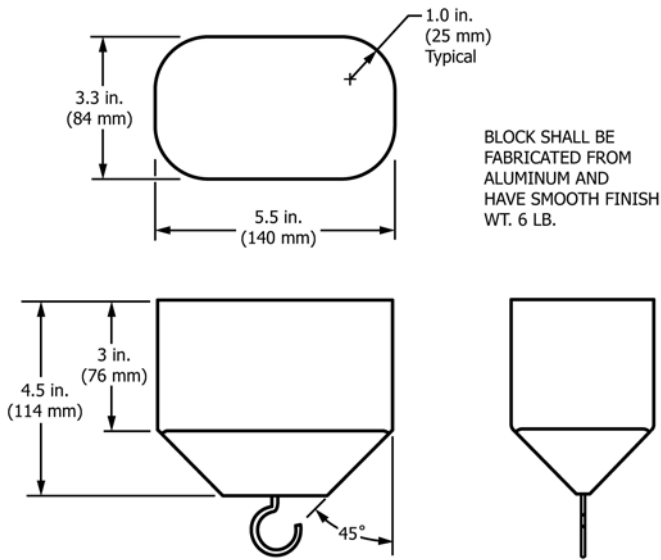

FIG. 2 Wedge Block

when tested per 7.8.4. Non-paper labels shall not liberate small parts when tested in accordance with 7.8.5.

5.10 *Corner Post Extensions*—No corner post assembly shall extend more than 0.06 in. (1.5 mm) above the upper edge of an end or side panel, whichever is higher, when measured from the lowest point on the upper edge of the end panel within 3 in. (76 mm) from the outermost contour of the elbow (see Fig. 3).

5.10.1 The limitations in 5.10 do not apply to a corner post assembly that extends at least 57 in. (1448 mm) above the uppermost surface of the mattress support.

5.10.2 Corner posts intended to accept removable vertical extensions made up of two or more segments (such as canopy post extensions) shall not permit the attachment of individual segments such that the resultant vertical extension would be in violation of the dimensional requirements of 5.10.

6. Performance Requirement

6.1 *Mattress Support System*—The mattress support system shall not disengage or create a hazardous condition as described in Section 5 of this consumer safety specification when tested in accordance with 7.2.

6.2 *Mattress Support System Attachment and Side Rails Integrity:*

6.2.1 The mattress support system and side rail attachment to the end structures shall not disengage or create a hazardous condition as described in Section 5 of this consumer safety specification when tested in accordance with 7.3.

6.2.2 In products that contain both side rails and a separate mattress support system, the tests described in 7.3.2 and 7.3.3 shall both apply.

6.3 *Mattress Support System Openings*—There shall be no openings in the mattress support system which will permit complete passage of the wedge block described in Fig. 2 when tested in accordance with 7.2.5.

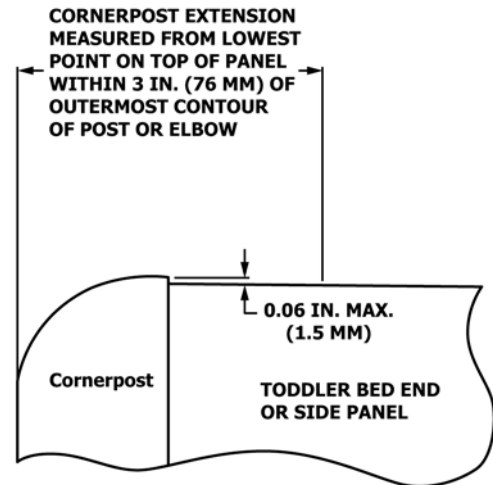

Illustration of Requirement in 5.10 for Corner Post Extensions

FIG. 3 Corner Post Extension

6.4 *Guardrails*—For products with guardrails, there shall be no opening in the guardrail structure below the lowest surface of the uppermost member of the guardrail and above the mattress support structure that will permit complete passage of the wedge block shown in Fig. 2 when tested in accordance with 7.4.

6.4.1 *Guardrail Height*—The upper edge of the guardrail shall be at least 5 in. above the top of the manufacturer's maximum specified mattress thickness. If no maximum mattress thickness is specified, the guardrail height shall be based on a mattress thickness of 6 in. (152 mm). This measurement is defined and shall be taken from the top of the mattress support in its lowest position to the top of the guardrail in the manufacturer's recommended use position. Using the previously defined measurement, subtract the manufacturer's recommended mattress thickness. The remaining difference (height) must be at least 5 in.

6.4.2 *Guardrail Strength*—When tested in accordance with 7.9 the guardrail shall not break, detach or create a condition that would present any of the hazards described in Section 5. Guardrails that do not have any free ends, that is that they are attached to both the headboard and the footboard, are exempt from this test. For guardrails with 2 free ends, perform this test at each free end.

6.5 *End Structures and Side Rails*—There shall be no openings between end structures or side rails and the mattress support system or above the mattress support system in the end structures or side rails that will permit complete passage of the wedge block shown in Fig. 2 when tested in accordance with 7.5.

6.6 *Partially Bounded Openings*—All partially bounded openings in the uppermost edge of any rigid structure of the bed above the level of the mattress support system shall comply with the requirements of 7.6.

6.7 *Spindle/Slat Static Load Strength:*

6.7.1 Toddler beds that contain wooden or metal spindles/slats shall meet the performance requirements outlined in section 6.7.2 or 6.7.3.

6.7.2 Except as provided in 6.7.3, after testing in accordance with the procedure in 7.10, there shall be no complete breakage of a spindle/slat or complete separation of a spindle/slat from the guardrails, side rails, or end structures.

6.7.3 Toddler beds that convert from a full-size crib, also known as convertible cribs, shall meet the requirements specified in subsection 6.7 of Specification F1169, approved June 1, 2010, instead of the requirements of 6.7.2. See 16 CFR Part 1219 for complete requirements for full-size cribs.

7. Test Methods

7.1 *Test Mattress*—A $4 \pm \frac{1}{8}$ in. (100 ± 3 mm) thick by $51\frac{5}{8} \pm \frac{1}{8}$ in. (1310 ± 3 mm) long by $27\frac{1}{4} \pm \frac{1}{8}$ in. (690 ± 3 mm) wide, open cell, polyurethane foam pad having a density of 1 lb/ft³ (16 kg/m³), having a compression load deflection of 30 lbf (133 N) when tested in accordance with Test Methods D3574, Method B1, to a 25 % deflection, covered with a 5 to 15 gage vinyl material, 0.005– to 0.015–in. (0.13– to 0.38–mm) thick shall be used to represent a mattress during the performance of the test in 7.2.4.

7.2 Mattress Support System:

7.2.1 Conduct the following test without a mattress in place unless specified otherwise.

7.2.2 Center a sheet of $\frac{3}{4}$ in. (19 mm) thick plywood 19 in. (480 mm) wide by 37 in. (940 mm) long on the mattress support system. Place a mass of 300 lb (136 kg) on the plywood sheet. The mass is to be distributed equally, applied gradually within a period of 5 s and shall remain in place for 5 min. Remove the mass.

7.2.3 Center a sheet of $\frac{3}{4}$ in. (19 mm) thick plywood 19 in. (480 mm) square on the longitudinal centerline of the mattress support system with one edge in line with the inside vertical plane of one end structure of the bed. Place a mass of 225 lb (102 kg) on the plywood sheet. The mass is to be distributed equally, applied gradually within a period of 5 s and shall remain in place for 5 min. Remove the mass. Repeat this test at the opposite end structure.

7.2.4 Place the test mattress on the bed. Secure a sheet of $\frac{3}{4}$ in. (19 mm) thick plywood 12 in. (305 mm) square in the center of the mattress support. Drop a 50 lb (22.7 kg) mass, whose size falls within the perimeter of the sheet of plywood from a distance of 12 in. (305 mm), 100 times onto the center of the sheet of plywood at a rate of 4 ± 1 seconds per cycle.

7.2.5 *Openings*—Without the test mattress on the bed, insert the tapered end of the wedge block shown in Fig. 2 in the most adverse orientation, into any opening in the mattress support system and gradually apply a 25 lbf (111 N) force perpendicular to the plane of the opening within a period of 5 s. Maintain this force for 30 s.

7.3 Mattress Support System Attachment and Side Rails Integrity Tests:

7.3.1 Conduct the following tests without a mattress in place.

7.3.2 *Mattress Support System*—Apply a downward vertical force of 225 lbf (1000 N) gradually within a period of 5 s evenly over a 2 in. (51 mm) length of the mattress support, 10 in. (255 mm) from one attachment point to a bed end structure. Maintain the force for 30 s. The test shall be conducted on each

long side of the mattress support at each end structure of the bed. If the mattress support system utilizes an identical support design at all points of attachment, testing is required only on one long side.

7.3.3 Side Rails:

7.3.3.1 Apply a downward vertical force of 225 lbf (1000 N) gradually within a period of 5 s evenly over a 2 in. (51 mm) length on the side rail, 10 in. from its attachment point to the bed end structure. Maintain the force for 30 s. Apply the force sequentially to each corner of the bed.

7.3.3.2 Apply a downward vertical force of 225 lbf (1000 N) gradually within a period of 5 s over a 2 in. (51 mm) length on the side rail, centered between the foot and head end structures. Maintain the force for 30 s. Apply the load sequentially to each side rail.

7.3.4 Apply a downward vertical force of 225 lbf (1000 N) gradually within a period of 5 s over a 2 in. (51 mm) length on the side rail, centered between the foot and head end structures on the side rail. Maintain the force for 30 s. Apply the load sequentially to each side rail.

7.4 Guardrails:

7.4.1 Assemble any guardrail in accordance with the manufacturer's instructions.

7.4.2 Without the test mattress on the bed, insert the tapered end of the wedge block shown in Fig. 2 in the most adverse orientation, into any opening in the guardrail structure above the level of the mattress support system, and gradually apply a 25 lbf (111 N) force perpendicular to the plane of the opening within a period of 5 s. Maintain this force for 30 s.

7.5 End Structures and Side Rails:

7.5.1 Without the test mattress on the bed, insert the tapered end of the wedge block shown in Fig. 2, in the most adverse orientation, into any opening between the end structure and the mattress support system and in the end structure above the level of the mattress support system, and gradually apply 25 lbf (111 N) perpendicular to the plane of the opening within a period of 5 s. Maintain this force for 30 s.

7.5.2 Without the test mattress on the bed, insert the tapered end of the wedge block shown in Fig. 2, in the most adverse orientation, into any opening between the side rails and the mattress support system and in the side rails above the level of the mattress support system, and gradually apply 25 lbf (111 N) perpendicular to the plane of the opening within a period of 5 s. Maintain this force for 30 s.

7.6 Partially Bounded Openings:

7.6.1 Using the “A” section of the test probe (see Fig. 4 and Fig. 5), align the probe so that its plane is horizontal and its centerline is perpendicular to the plane of any structure containing a partially bounded opening in its uppermost edge. Lower the “A” section of the probe into the opening until motion is arrested by contact between the probe and boundaries of the opening (see Fig. 6). By visual inspection, determine if the uppermost face of the probe is above the uppermost edge of the structure containing the opening (see Fig. 7(a)). The opening conforms and the test in 7.6.2 is not required if the uppermost face of the probe remains above the uppermost edge of the structure. If the uppermost face of the probe is below the

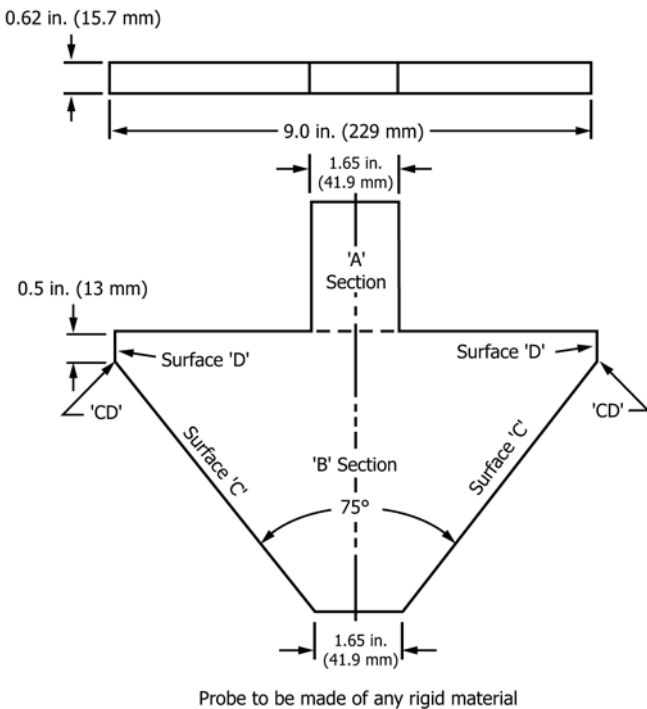

FIG. 4 Test Probe for Partially Bounded Openings

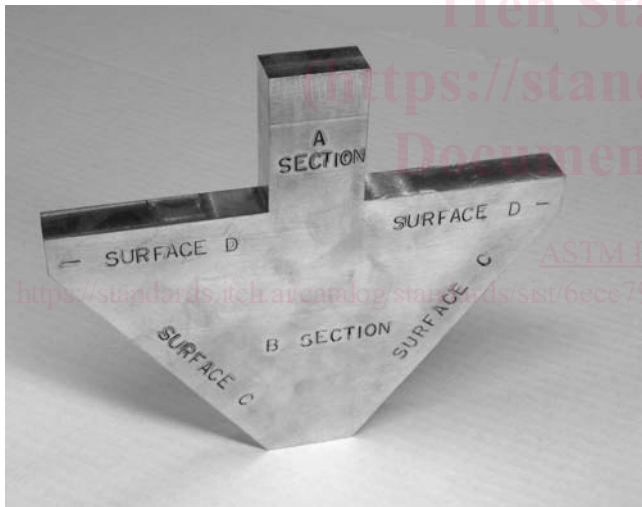

FIG. 5 Fish Probe Shown for Clarity

uppermost edge of the structure containing the opening (see Fig. 7(b)), perform the test in 7.6.2.

7.6.2 Align the test probe so that its plane is in the plane of the structure containing the partially bounded opening and the “B” section of the probe is facing toward the opening. With the probe oriented so that its centerline is parallel to the centerline of the opening, move it into the opening until motion is arrested by contact between the probe and the boundaries of the opening. By visual inspection, determine the location of the contact points on the probe with the boundaries of the opening. If there is simultaneous contact between surfaces “C” or “D” or corners “CD” in any combination that are on opposite sides of the probe centerline (see Fig. 8), the opening fails to conform.

7.7 Removal of Protective Components:

7.7.1 Any protective component that a child may reasonably be expected to grasp at least between the thumb and forefinger, or teeth, or which has a 0.040 in. (1.00 mm) gap between itself and its adjacent parent component shall be tested in accordance with each of the following methods in the sequence listed.

7.7.2 Secure the bed so that it cannot move during the performance of the following tests.

7.7.3 Torque Tests—A torque of 4 lbf-in. (0.5 N • m) shall be applied gradually within a period of 5 s in a clockwise direction until a rotation of 180° from the original position has been attained or 4 lbf-in. has been reached. The torque or maximum rotation shall be maintained for an additional 10 s. The torque shall then be removed and the test components permitted to return to a relaxed condition. This procedure shall then be repeated in the counter clockwise direction.

7.7.4 Tension Test:

7.7.4.1 Attach a force gage to the protective component by means of any suitable device. A clamp such as shown in Fig. 10 may be a suitable device for components that cannot reasonably be expected to be grasped between the thumb and forefinger, or teeth, on their outer diameter but have a gap of 0.040 in. (1.00 mm) or more between the rear surface of the component and the structural member of the bed to which they are attached.

7.7.4.2 Be sure that the attachment device does not compress or expand the component to hinder removal of the component.

7.7.4.3 Apply 15 lbf (67 N) gradually in the direction that would normally be associated with removal of the protective component. Apply the force within 5 s, and maintain for an additional 10 s.

7.8 Permanency of Labels and Warnings:

7.8.1 A paper label (excluding labels attached by a seam) shall be considered permanent if, during an attempt to remove it without the aid of tools or solvents, it cannot be removed, it tears into pieces upon removal, or such action damages the surface to which it is attached.

7.8.2 A non-paper label (excluding labels attached by a seam) shall be considered permanent if, during an attempt to remove it without the aid of tools or solvents, it cannot be removed or such action damages the surface to which it is attached.

7.8.3 A warning label attached by a seam shall be considered permanent if it does not detach when subjected to a 15-lbf (67-N) pull force applied in any direction most likely to cause failure using a 3/4 -in. (19-mm) diameter clamp surface. Gradually apply the force over 5 s and maintain for an additional 10 s.

7.8.4 Adhesion test for warnings applied directly onto the surface of the product.

7.8.4.1 Apply the tape test defined in Test Method B, Cross-Cut Tape Test of Test Methods D3359, eliminating parallel cuts.

7.8.4.2 Perform this test once in each different location where warnings are applied.

7.8.4.3 The warning statements will be considered permanent if the printing in the area tested is still legible and attached after being subjected to this test.