



Standard Test Methods for Sampling and Testing Brick and Structural Clay Tile¹

This standard is issued under the fixed designation C67/C67M; the number immediately following the designation indicates the year of original adoption or, in the case of revision, the year of last revision. A number in parentheses indicates the year of last reapproval. A superscript epsilon (ϵ) indicates an editorial change since the last revision or reapproval.

This standard has been approved for use by agencies of the U.S. Department of Defense.

1. Scope*

1.1 These test methods cover procedures for the sampling and testing of brick and structural clay tile. Although not necessarily applicable to all types of units, tests include modulus of rupture, compressive strength, absorption, saturation coefficient, effect of freezing and thawing, efflorescence, initial rate of absorption and determination of weight, size, warpage, length change, and void area. (Additional methods of test pertinent to ceramic glazes include imperviousness, chemical resistance, opacity, and resistance to crazing.

1.2 The text of this standard references notes and footnotes which provide explanatory material. These notes and footnotes (excluding those in tables and figures) shall not be considered as requirements of the standard.

NOTE 1—The testing laboratory performing this test method should be evaluated in accordance with Practice C1093.

1.3 The values stated in either SI units or inch-pound units are to be regarded separately as standard. The values stated in each system may not be exact equivalents; therefore, each system shall be used independently of the other. Combining values from the two systems may result in non-conformance with the standard.

1.4 These test methods include the following sections:

Section Heading	Section
Scope	1
Referenced Documents	2
Terminology	3
Sampling	4
Specimen Preparation	5
Modulus of Rupture (Flexure Test)	6
Compressive Strength	7
Absorption	8
Freezing and Thawing	9
Initial Rate of Absorption (Suction) (Laboratory Test)	10
Efflorescence	11
Weight Per Unit Area	12
Measurement of Size	13
Measurement of Warpage	14
Measurement of Length Change	15
Initial Rate of Absorption (Suction) (Field Test)	16
Measurement of Void Area in Cored Units	17
Measurement of Void Area in Deep Froged Units	18
Measurement of Out of Square	19
Measurement of Shell and Web Thickness	20
Breaking Load	21
Imperviousness Test (of Ceramic Glazes)	22
Chemical Resistance Test (of Ceramic Glazes)	23
Autoclaved Crazing Test (of Ceramic Glazes)	24
Opacity Test (of Ceramic Glazes)	25
Precision and Bias	26
Keywords	27

¹ These test methods are under the jurisdiction of Committee C15 on Manufactured Masonry Units and is the direct responsibility of Subcommittee C15.02 on Brick and Structural Clay Tile.

Current edition approved Feb. 1, 2018; July 1, 2019. Published March 2018; July 2019. Originally approved in 1937. Last previous edition approved in 2017 as C67—17-C67/C67M—18. DOI: 10.1520/C0067_C0067M-18; 10.1520/C0067_C0067M-19.

*A Summary of Changes section appears at the end of this standard

1.5 *This standard does not purport to address all of the safety concerns, if any, associated with its use. It is the responsibility of the user of this standard to establish appropriate safety, health, and environmental practices and determine the applicability of regulatory limitations prior to use.*

1.6 *This international standard was developed in accordance with internationally recognized principles on standardization established in the Decision on Principles for the Development of International Standards, Guides and Recommendations issued by the World Trade Organization Technical Barriers to Trade (TBT) Committee.*

2. Referenced Documents

2.1 ASTM Standards:²

~~C150~~[C150/C150M](#) Specification for Portland Cement

[C1093](#) Practice for Accreditation of Testing Agencies for Masonry

[C1232](#) Terminology for Masonry

[E4](#) Practices for Force Verification of Testing Machines

[E6](#) Terminology Relating to Methods of Mechanical Testing

[E177](#) Practice for Use of the Terms Precision and Bias in ASTM Test Methods

[E691](#) Practice for Conducting an Interlaboratory Study to Determine the Precision of a Test Method

3. Terminology

3.1 *Definitions*—For definitions relating to sampling and testing brick, refer to Terminology [E6](#) and Terminology [C1232](#).

4. Sampling

4.1 *Selection and Preparation of Test Specimens*—For the purpose of these tests, full-size brick, tile, or solid masonry units shall be selected by the purchaser or by the purchaser's authorized representative. Specimens shall be representative of the lot of units from which they are selected and shall include specimens representative of the complete range of colors, textures, and sizes. Specimens shall be free of or brushed to remove dirt, mud, mortar, or other foreign materials unassociated with the manufacturing process. Brushes used to remove foreign material shall have bristles of plastic (polymer) or horsehair. Wire brushes shall not be used for preparing specimens for testing. Specimens exhibiting foreign material that is not removed by brushing shall be discarded to ensure that damaged or contaminated specimens are not tested.

4.2 Number of Specimens:

4.2.1 *Brick*—For the modulus of rupture, compressive strength, abrasion resistance, and absorption determinations, at least ten individual brick shall be selected for lots of 1 000 000 brick or fraction thereof. For larger lots, five additional specimens shall be selected from each additional 500 000 brick or fraction thereof. Additional specimens are taken at the discretion of the purchaser.

4.2.2 *Structural Clay Tile*—For the weight determination and for compressive strength and absorption tests, at least five tile shall be selected from each lot of 250 tons (~~250 mt~~)[250 mt] or fraction thereof. For larger lots, five additional specimens shall be tested for each 500 tons (~~500 mt~~)[500 mt] or fraction thereof. In no case shall less than five tile be taken. Additional specimens are taken at the discretion of the purchaser.

4.2.3 *Ceramic Glazed Units*—For imperviousness, chemical resistance, crazing, and opacity tests, select a representative of 10 units for lots of 1 000 000 units, or fraction thereof. For larger lots, select five additional specimens from each additional 500 000 units, or fraction thereof. Do not use specimens selected for [4.2.1](#) or [4.2.2](#).

4.3 *Identification*—Each specimen shall be marked so that it is identifiable at any time. Markings shall cover not more than 5 % of the superficial area of the specimen.

5. Specimen Preparation

5.1 Drying and Cooling:

5.1.1 *Drying*—Dry the test specimens in a ventilated oven at 221 to 239°F (~~105 to 115°C~~)[105 to 115°C] for not less than 24 h and until two successive weighings at intervals of 2 h show an increment of loss not greater than 0.2 % of the last previously determined weight of the specimen.

5.1.2 *Cooling*—After drying, cool the specimens in a drying room maintained at a temperature of 75 ± 15°F (~~24 to 28°C~~)[24 ± 8°C; 8°C], with a relative humidity between 30 and 70 %. Store the units free from drafts, unstacked, with separate placement, for a period of at least 4 h and until the surface temperature is within 5°F (~~2.8°C~~)[2.8°C] of the drying room temperature. Do not use

² For referenced ASTM standards, visit the ASTM website, www.astm.org, or contact ASTM Customer Service at service@astm.org. For *Annual Book of ASTM Standards* volume information, refer to the standard's Document Summary page on the ASTM website.

specimens noticeably warm to the touch for any test requiring dry units. The specimens shall be stored in the drying room with the required temperature and humidity maintained until tested.

5.1.2.1 An alternative method of cooling the specimens to approximate room temperature is permitted as follows: Store units, unstacked, with separate placement, in a ventilated room maintained at a temperature of $75 \pm 15^\circ\text{F}$ ($24[24 \pm 8^\circ\text{C}]; 8^\circ\text{C}$), with a relative humidity between 30 and 70 % for a period of 4 h and until the surface temperature is within 5°F (2.8°C) [2.8°C] of the ventilated room temperature, with a current of air from an electric fan passing over them for a period of at least 2 hours. The specimens shall be stored in the ventilated room with the required temperature and humidity maintained until tested.

5.2 Weight Determination:

5.2.1 Weigh five full size specimens that have been dried and cooled (see 5.1). The scale or balance used shall have a capacity of not less than 3000 g and shall be sensitive to 0.5 g.

5.2.2 Report results separately for each specimen to the nearest 0.1 g, with the average of all specimens tested to the nearest 0.1 g.

5.3 *Removal of Silicone Coatings from Brick Units*—The silicone coatings intended to be removed by this process are any of the various polymeric organic silicone compounds used for water-resistant coatings of brick units. Heat the brick at $950 \pm 50^\circ\text{F}$ ($510[510 \pm 28^\circ\text{C}]; 28^\circ\text{C}$) in an oxidizing atmosphere for a period of not less than 3 hours. The rate of heating and cooling shall not exceed 300°F (149°C) [149°C] per hour.

NOTE 2—Additional specimen preparation requirements for specific tests are indicated in the individual test methods.

6. Modulus of Rupture (Flexure Test)

6.1 *Test Specimens*—The test specimens shall consist of whole full-size units that have been dried and cooled (see 5.1). Five such specimens shall be tested.

6.2 Procedure:

6.2.1 Support the test specimen flatwise unless specified and reported otherwise (that is, apply the load in the direction of the depth of the unit) on a span approximately 1 in. (25 mm) [25 mm] less than the basic unit length and loaded at midspan. Specimens having recesses (panels or depressions) shall be placed so that such recesses are on the compression side. Apply the load to the upper surface of the specimen through a steel bearing plate $\frac{1}{4}$ in. (6 mm) [6 mm] in thickness and $1\frac{1}{2}$ in. (38 mm) [38 mm] in width and of a length at least equal to the width of the specimen.

6.2.2 Make sure the supports for the test specimen are free to rotate in the longitudinal and transverse directions of the test specimen and adjust them so that they will exert no force in these directions.

6.2.3 *Speed of Testing*—The rate of loading shall not exceed 2000 lbf (9000 N)/min. [9000 N]/min. This requirement is considered as being met when the speed of the moving head of the testing machine immediately prior to application of the load is not more than 0.05 in. (1.25 mm)/min. [1.25 mm]/min.

6.3 Calculation and Report:

6.3.1 Calculate and report the modulus of rupture of each specimen to the nearest 1 psi (0.01 MPa) [0.01 MPa] as follows:

$$S = 3W(1/2 - x)/bd^2 \quad (1)$$

where:

S = modulus of rupture of the specimen at the plane of failure, lb/in.^2 (Pa),

W = maximum load indicated by the testing machine, lbf (N),

l = distance between the supports, in. (mm),

b = net width, (face to face minus voids), of the specimen at the plane of failure, in. (mm),

d = depth, (bed surface to bed surface), of the specimen at the plane of failure, in. (mm), and

x = average distance from the midspan of the specimen to the plane of failure measured in the direction of the span along the centerline of the bed surface subjected to tension, in. (mm).

S = modulus of rupture of the specimen at the plane of failure, lb/in.^2 [Pa],

W = maximum load indicated by the testing machine, lbf [N],

l = distance between the supports, in. [mm],

b = net width, (face to face minus voids), of the specimen at the plane of failure, in. [mm],

d = depth, (bed surface to bed surface), of the specimen at the plane of failure, in. [mm], and

x = average distance from the midspan of the specimen to the plane of failure measured in the direction of the span along the centerline of the bed surface subjected to tension, in. [mm].

6.3.2 Calculate and report the average of the modulus of rupture determinations to the nearest 1 psi (0.01 MPa) [0.01 MPa].

7. Compressive Strength

7.1 Test Specimens:

7.1.1 *Brick*—The test specimens shall consist of half brick units that have been dried and cooled (see 5.1), the full height and width of the unit, with a length equal to one half the full length of the unit ± 1 in. (~~25 mm~~); [25 mm], except as described below. When the test specimen, described above, exceeds the testing machine capacity, the test specimens shall consist of dry pieces of brick, the full height and width of the unit, with a length not less than one quarter of the full length of the unit, and with a gross cross-sectional area perpendicular to bearing not less than 14 in.² (~~90~~[90 cm²]). Test specimens shall be obtained by any method that will produce, without shattering or cracking, a specimen with approximately plane and parallel ends. Five specimens shall be tested.

7.1.2 *Structural Clay Tile*—Test five tile specimens that have been dried and cooled (see 5.1) in a bearing bed length equal to the width ± 1 in. (~~25 mm~~); [25 mm]; or test full-size units.

7.2 Capping Test Specimens:

7.2.1 All specimens shall be dry and cool within the meaning of 5.1.1 and 5.1.2 before any portion of the capping procedure is carried out.

7.2.2 Fill recessed or paneled surfaces that will become bearing surfaces during the compression test with a mortar composed of 1 part by weight of quick-hardening cement conforming to the requirements for Type III cement of Specification **C150/C150M**, and 2 parts by weight of sand. Age the specimens at least 48 h before capping them. Where the recess exceeds $\frac{1}{2}$ in. (~~12.5 mm~~); [12.5 mm], use a brick or tile slab section or metal plate as a core fill. Cap the test specimens using one of the two procedures described in 7.2.3 and 7.2.4.

7.2.3 *Gypsum Capping*—Coat the two opposite bearing surfaces of each specimen with shellac and allow to dry thoroughly. Bed one of the dry shellacked surfaces of the specimen in a thin coat of neat paste of calcined gypsum (plaster of paris) that has been spread on an oiled nonabsorbent plate, such as glass or machined metal. The casting surface plate shall be plane within 0.003 in. (~~0.1 mm~~); [0.1 mm] in 16 in. (~~400 mm~~); [400 mm] and sufficiently rigid; and so supported that it will not be measurably deflected during the capping operation. Lightly coat it with oil or other suitable material. Repeat this procedure with the other shellacked surface. Take care that the opposite bearing surfaces so formed will be approximately parallel and perpendicular to the vertical axis of the specimen and the thickness of the caps will be approximately the same and not exceeding $\frac{1}{8}$ in. (~~3 mm~~); [3 mm]. Age the caps at least 24 h before testing the specimens.

NOTE 3—A rapid-setting industrial type gypsum is frequently used for capping.

7.2.4 *Sulfur-Filler Capping*—Use a mixture containing 40 to 60 weight % sulfur, the remainder being ground fire clay or other suitable inert material passing a No. 100 (~~150- μ m~~); [150- μ m] sieve with or without plasticizer. The casting surface plate requirements shall be as described in 7.2.3. Place four 1-in. (~~25 mm~~); [25 mm] square steel bars on the surface plate to form a rectangular mold approximately $\frac{1}{2}$ in. (~~12.5 mm~~); [12.5 mm] greater in either inside dimension than the specimen. Heat the sulfur mixture in a thermostatically controlled heating pot to a temperature sufficient to maintain fluidity for a reasonable period of time after contact with the surface being capped. Take care to prevent overheating, and stir the liquid in the pot just before use. Fill the mold to a depth of $\frac{1}{4}$ in. (~~6 mm~~); [6 mm] with molten sulfur material. Place the surface of the unit to be capped quickly in the liquid, and hold the specimen so that its vertical axis is at right angles to the capping surface. The thickness of the caps shall be approximately the same. Allow the unit to remain undisturbed until solidification is complete. Allow the caps to cool for a minimum of 2 h before testing the specimens.

7.3 Procedure:

7.3.1 Test brick specimens flatwise (that is, the load shall be applied perpendicular to the bed surface of the brick with the brick in the stretcher position). Test structural clay tile specimens in a position such that the load is applied in the same direction as in service. Center the specimens under the spherical upper bearing within $\frac{1}{16}$ in. (~~2 mm~~); [2 mm].

7.3.2 The testing machine shall conform to the requirements of Practices **E4**.

7.3.3 The upper bearing shall be a spherically seated, hardened metal block firmly attached at the center of the upper head of the machine. The center of the sphere shall lie at the center of the surface of the block in contact with the specimen. The block shall be closely held in its spherical seat, but shall be free to turn in any direction, and its perimeter shall have at least $\frac{1}{4}$ in. (~~6 mm~~); [6 mm] clearance from the head to allow for specimens whose bearing surfaces are not exactly parallel. The diameter of the bearing surface shall be at least 5 in. (~~125 mm~~); [125 mm]. Use a hardened metal bearing block beneath the specimen to minimize wear of the lower platen of the machine. The bearing block surfaces intended for contact with the specimen shall have a hardness not less than HRC60 (HB 650). These surfaces shall not depart from plane surfaces by more than 0.001 in. (~~0.03 mm~~); [0.03 mm]. When the bearing area of the spherical bearing block is not sufficient to cover the area of the specimen, place a steel plate with surfaces machined to true planes within ± 0.001 in. (~~0.03 mm~~); [0.03 mm], and with a thickness equal to at least one third of the distance from the edge of the spherical bearing to the most distant corner between the spherical bearing block and the capped specimen.

7.3.4 *Speed of Testing*—Apply the load, up to one half of the expected maximum load, at any convenient rate, after which, adjust the controls of the machine so that the remaining load is applied at a uniform rate in not less than 1 nor more than 2 min.

7.4 Calculation and Report:

7.4.1 Calculate and report the compressive strength of each specimen to the nearest 10 psi (~~70 kPa~~); [70 kPa] as follows:

Compressive strength, $C = W/A$

(2)

where:

C = compressive strength of the specimen, lb/in.² (or kg/cm²) (or Pa·10⁴),
 W = maximum load, lbf, (or kgf) (or N), indicated by the testing machine, and
 A = average of the gross areas of the upper and lower bearing surfaces of the specimen, in.² (or cm²).

C = compressive strength of the specimen, lb/in.² [or kg/cm²] [or Pa·10⁴],
 W = maximum load, lbf, [or kgf] [or N], indicated by the testing machine, and
 A = average of the gross areas of the upper and lower bearing surfaces of the specimen, in.² [or cm²].

NOTE 4—When compressive strength is to be based on net area (example: clay floor tile), substitute for A in the above formula the net area, in in.² (or cm²), of the fired clay in the section of minimum area perpendicular to the direction of the load.

7.4.2 Calculate and report the average of the compressive strength determinations to the nearest 10 psi (70 kPa); [70 kPa].

8. Absorption

8.1 Accuracy of Weighings:

8.1.1 *Brick*—The scale or balance used shall have a capacity of not less than 2000 g, and shall be sensitive to 0.5 g.

8.1.2 *Tile*—The balance used shall be sensitive to within 0.2 % of the weight of the smallest specimen tested.

8.2 Test Specimens:

8.2.1 *Brick*—The test specimens shall consist of half brick conforming to the requirements of 7.1.1. Five specimens shall be tested.

8.2.2 *Tile*—The specimens for the absorption test shall consist of five tile or three representative pieces from each of these five tile. Two of the three representative pieces shall be taken from the shells and one from an interior web, the weight of each piece being not less than 225 g. The specimens shall have had their rough edges or loose particles ground off. Pieces taken from tile that have been subjected to compressive strength tests shall be free of cracks due to failure in compression.

8.3 5-h and 24-h Submersion Tests:

8.3.1 Procedure:

8.3.1.1 Dry and cool the test specimens in accordance with 5.1 and weigh each one in accordance with 5.2.

8.3.1.2 *Saturation*—Submerge the dry, cooled specimen, without preliminary partial immersion, in clean water (soft, distilled or rain water) at 60 to 86°F (15.5[15.5 to 30°C]30°C) for the specified time. Remove the specimen, wipe off the surface water with a damp cloth and weigh the specimen. Complete weighing of each specimen within 5 min after removing the specimen from the bath.

8.3.2 Calculation and Report:

8.3.2.1 Calculate and report the cold water absorption of each specimen to the nearest 0.1 % as follows:

$$\text{Absorption, \%} = 100(W_s - W_d)/W_d \quad (3)$$

where:

W_d = dry weight of the specimen, and

W_s = saturated weight of the specimen after submersion in cold water.

8.3.2.2 Calculate and report the average cold water absorption of all specimens to the nearest 0.1 %.

8.4 1-h, 2-h, and 5-h Boiling Tests:

8.4.1 *Test Specimens*—The test specimens shall be the same five specimens used in the 5-h or 24-h cold-water submersion test where required and shall be used in the state of saturation existing at the completion of that test.

8.4.1.1 Dry and cool the test specimens in accordance with 5.1 when performing the boiling water absorption test without previously conducting the cold water absorption test.

8.4.2 Procedure:

8.4.2.1 Return the specimen that has been subjected to the cold-water submersion to the bath, and subject it to the boiling test as described in 8.4.2.2.

8.4.2.2 Submerge the specimen in clean water (soft, distilled or rain water) at 60 to 86°F (15.5[15.5 to 30°C]30°C) in such a manner that water circulates freely on all sides of the specimen. Heat the water to boiling, within 1 h, boil continuously for specified time, and then allow to cool to 60 to 86°F (15.5[15.5 to 30°C]30°C) by natural loss of heat. Remove the specimen, wipe off the surface water with a damp cloth, and weigh the specimen. Complete weighing of each specimen within 5 min after removing the specimen from the bath.

8.4.2.3 When the tank is equipped with a drain so that water at 60 to 86°F (15.5[15.5 to 30°C]30°C) passes through the tank continuously and at such a rate that a complete change of water takes place in not more than 2 min, make weighings at the end of 1 hour.

8.4.3 Calculation and Report:

8.4.3.1 Calculate and report the boiling water absorption of each specimen to the nearest 0.1 % as follows:

$$\text{Absorption, \%} = 100(W_b - W_d)/W_d \quad (4)$$

where:

W_d = dry weight of the specimen, and

W_b = saturated weight of the specimen after submersion in boiling water.

8.4.3.2 Calculate and report the average boiling water absorption of all specimens to the nearest 0.1 %.

8.5 Saturation Coefficient:

8.5.1 Calculate and report the saturation coefficient of each specimen to the nearest 0.01 as follows:

$$\text{Saturation coefficient} = (W_{c(24)} - W_d)/(W_{b(5)} - W_d) \quad (5)$$

where:

W_d = dry weight of the specimen,

$W_{c(24)}$ = saturated weight of the specimen after 24-h submersion in cold water, and

$W_{b(5)}$ = saturated weight of the specimen after 5-h submersion in boiling water.

8.5.2 Calculate and report the average saturation coefficient of all specimens to the nearest 0.01.

9. Freezing and Thawing

9.1 Apparatus:

9.1.1 *Compressor, Freezing Chamber, and Circulator* of such design and capacity that the temperature of the air in the freezing chamber will not exceed 16°F (−9°C) [−9°C] 1 h after introducing the maximum charge of units, initially at a temperature not exceeding 90°F (32°C) [32°C].

9.1.2 *Trays and Containers*, shallow, metal, having an inside depth of 1½ ± ½ in. (38[38 ± 12.5 mm]; mm), and of suitable strength and size so that the tray with a charge of frozen units is movable by one technician.

9.1.3 *Balance*, having a capacity of not less than 2000 g and sensitive to 0.5 g.

9.1.4 *Drying Oven* that provides a free circulation of air through the oven and is capable of maintaining a temperature between 221 and 239°F (105[105 and 115°C]; 115°C).

9.1.5 *Thawing Tank* of such dimensions as to permit complete submersion of the specimens in their trays. Adequate means shall be provided so that the water in the tank is kept at a temperature of 75 ± 10°F (24[24 ± 5.5°C]; 5.5°C).

9.1.6 *Drying Room*, maintained at a temperature of 75 ± 15°F (24[24 ± 8°C]; 8°C), with a relative humidity between 30 and 70 %, and free from drafts.

9.2 Test Specimens:

9.2.1 *Brick*—The test specimens shall consist of half brick with approximately plane and parallel ends. When necessary, smooth any rough ends by trimming off a thin section with a masonry saw. Specimens damaged in the sawing process shall be discarded. The specimens shall be free from shattering or unsoundness, visually observed, resulting from the flexure or from the absorption tests. Additionally, prepare specimens by removing all loosely adhering particles, sand or edge shards from the surface or cores. Test five specimens.

9.2.2 *Structural Clay Tile*—The test specimens shall consist of five tile or of a cell not less than 4 in. (100 mm) [101.6 mm] in length sawed from each of the five tile. Specimens damaged in the sawing process shall be discarded.

9.3 Procedure:

9.3.1 Dry and cool the test specimens in accordance with 5.1. Weigh and record the dry weight of each in accordance with 5.2.

9.3.2 Carefully examine each specimen for cracks. A crack is defined as a fissure or separation visible to a person with normal vision from a distance of one foot under an illumination of not less than 50 fc (540 lx) [540 lx]. Mark each crack its full length with an indelible felt marking pen.

9.3.3 Submerge the test specimens in the water of the thawing tank for 4 ± ½ h.

9.3.4 Remove the specimens from the thawing tank and stand them in the freezing trays with one of their head faces down. Head face is defined as the end surfaces of a whole rectangular brick (which have the smallest area). (See Note 5.) A space of at least ½ in. (12.5 mm) [12.5 mm] shall separate the specimens as placed in the tray. Pour sufficient water into the trays so that each specimen stands in ½ in. (12.5 mm) [12.5 mm] depth of water and then place the trays and their contents in the freezing chamber for 20 ± 1 h.

NOTE 5—The dimensions of some brick may prevent specimens from standing without support on one of their head faces. In such a case, any suitable rack or support that will achieve the ½ in. (12.5 mm) [12.5 mm] separation of specimens and the specimen standing in ½ in. (12.5 mm) [12.5 mm] depth of water will suffice.

9.3.5 Remove the trays from the freezing chamber after 20 ± 1 h and totally immerse them and their contents in the water of the thawing tank for 4 ± ½ h.

9.3.6 Freeze the test specimens by the procedure in 9.3.4 one cycle each day of the normal work week. Following the 4 ± ½ h thawing after the last freeze-thaw cycle of the normal work week, remove the specimens from the trays and store them for 44 ± 1 h in the drying room. Do not stack or pile units. Provide a space of at least 1 in. (25 mm) [25 mm] between all specimens.

Following this period of air drying, inspect the specimens, submerge them in the water of the thawing tank for $4 \pm \frac{1}{2}$ h, and again subject them to a normal week of freezing and thawing cycles in accordance with 9.3.4 and 9.3.5. When a normal 5-day work week is interrupted, put specimens into a drying cycle, which meets or extends past the 44 ± 1 h drying time outlined in the procedures of this section.

9.3.7 Continue the alternations of drying and submersion in water for $4 \pm \frac{1}{2}$ h, followed by 5 cycles of freezing and thawing or the number of cycles needed to complete a normal work week, until a total of 50 cycles of freezing and thawing has been completed. Stop the test when the test specimen develops a crack as defined in 9.4.3, breaks, or appears to have lost more than 3 % of its original weight by disintegration as judged by visual inspection.

9.3.8 After completion of 50 cycles, or when the test specimen has been withdrawn from test as a result of disintegration, dry and weigh the specimen as prescribed in 9.3.1.

9.4 Calculations, Examination, Rating and Report:

9.4.1 *Calculation*—Calculate the loss in weight as a percentage of the original weight of the dried specimen.

9.4.2 *Examination*—Re-examine the surface of the specimens for cracks (see 9.3.2) and record the presence of any new cracks developed during the freezing-thawing testing procedure. Measure and record the length of the new cracks and any extensions of previously marked cracks. Examine the specimens for disintegration during the freeze-thaw process.

9.4.3 *Rating*—A specimen is considered to fail the freezing and thawing test under any of the following circumstances:

9.4.3.1 *Breakage and Weight Loss*—A separation or disintegration resulting in a weight loss of greater than that permitted by the referenced unit specification for the appropriate classification.

9.4.3.2 *Cracking*—A specimen develops a crack during the freezing and thawing procedure that exceeds the length permitted by the referenced unit standard for the appropriate classification. If none of the above circumstances occur, the specimens are considered to pass the freezing and thawing test.

9.4.4 *Report*—The report shall state whether the sample passed or failed the test. Any failures shall include the rating and the reason for classification as a failure and the number of cycles causing failure in the event failure occurs prior to 50 cycles.

10. Initial Rate of Absorption (Suction) (Laboratory Test)

10.1 Apparatus:

10.1.1 *Trays or Containers*—Watertight trays or containers, having an inside depth of not less than $\frac{1}{2}$ in. (~~12.5 mm~~)[12.5 mm], and of such length and width that an area of not less than 300 in.² (~~2000~~[2000 cm²]) of water surface is provided. The bottom of the tray shall provide a plane, horizontal upper surface, when suitably supported, so that an area not less than 8 in. (~~200 mm~~)[200 mm] in length by 6 in. (~~150 mm~~)[150 mm] in width will be level when tested by a spirit level.

10.1.2 *Supports for Brick*—Two noncorrodible metal supports consisting of bars between 5 and 6 in. (~~125~~[125 and 150 mm]mm) in length, having triangular, half-round, or rectangular cross sections such that the thickness (height) will be approximately $\frac{1}{4}$ in. (~~6 mm~~)[6 mm]. The thickness of the two bars shall agree within 0.001 in. (~~0.03 mm~~)[0.03 mm] and, when the bars are rectangular in cross section, their width shall not exceed $\frac{5}{16}$ in. (~~8 mm~~)[8 mm].

10.1.3 *Means for Maintaining Constant Water Level*—Suitable means for controlling the water level above the upper surface of the supports for the brick within ± 0.01 in. (~~0.25 mm~~)[0.25 mm] (see Note 6), including means for adding water to the tray at a rate corresponding to the rate of removal by the brick undergoing test (see Note 7). For use in checking the adequacy of the method of controlling the rate of flow of the added water, a reference brick or half brick shall be provided whose displacement in $\frac{1}{8}$ in. (~~3 mm~~)[3 mm] of water corresponds to the brick or half brick to be tested within ± 2.5 %. Completely submerge the reference brick in water for not less than 3 h preceding its use.

NOTE 6—A suitable means for obtaining accuracy in control of the water level is provided by attaching to the end of one of the bars two stiff metal wires that project upward and return, terminating in points; one of which is $\frac{1}{8} - 0.01$ in. (~~3.00 - 0.25 mm~~)[3.00 - 0.25 mm] and the other $\frac{1}{8} + 0.01$ in. (~~3.00 + 0.25 mm~~)[3.00 + 0.25 mm] above the upper surface or edge of the bar. Such precise adjustment is obtainable by the use of depth plates or a micrometer microscope. When the water level with respect to the upper surface or edge of the bar is adjusted so that the lower point dimples the water surface when viewed by reflected light and the upper point is not in contact with the water, the water level is within the limits specified. Any other suitable means for fixing and maintaining a constant depth of immersion shall be permitted when equivalent accuracy is obtained. An example of such other suitable means is the use of rigid supports movable with respect to the water level.

NOTE 7—A rubber tube leading from a siphon or gravity feed and closed by a spring clip will provide a suitable manual control. The so-called “chicken-feed” devices as a rule lack sensitivity and do not operate with the very small changes in water level permissible in this test.

10.1.4 *Balance*, having a capacity of not less than 3000 g, and sensitive to 0.5 g.

10.1.5 *Drying Oven*, conforming to the requirements of 9.1.4.

10.1.6 *Timing Device*—A suitable timing device, preferably a stop watch or stop clock, which shall indicate a time of 1 min to the nearest 1 s.

10.2 *Test Specimens*, consisting of whole brick. Five specimens shall be tested.

10.3 Procedure:

10.3.1 The initial rate of absorption shall be determined for the test specimen as specified, either oven-dried or ambient air-dried. When not specified, the initial rate of absorption shall be determined for the test specimens oven-dried. Dry and cool the test specimens in accordance with the applicable procedures 10.3.1.1 or 10.3.1.2. Complete the test procedure in accordance with 10.3.2, 10.3.3, and 10.3.4.

NOTE 8—There is no correlated relationship between the value of initial rate of absorption for ambient air-dried and oven-dried units. The test methods provide different information.

10.3.1.1 *Oven-dried Procedure*—Dry and cool the test specimens in accordance with 5.1.

10.3.1.2 *Ambient Air-dried Procedure*—Store units unstacked, with separate placement in a ventilated room maintained at a temperature of $75 \pm 15^\circ\text{F}$ ($24[24 \pm 8^\circ\text{C}]8^\circ\text{C}$) with a relative humidity between 30 % and 70 % for a period of 4 h, with a current of air from an electric fan passing over them for a period of at least 2 hours. Continue until two successive weighings at intervals of 2 h show an increment of loss not greater than 0.2 % of the last previously determined weight of the specimen.

10.3.2 Measure to the nearest 0.05 in. (1.25 mm) the length and width of the flatwise surface of the test specimen of rectangular units or determine the area of other shapes to similar accuracy that will be in contact with the water. Weigh the specimen to the nearest 0.5 g.

10.3.3 Adjust the position of the tray for the absorption test so that the upper surface of its bottom will be level when tested by a spirit level, and set the saturated reference brick (10.1.3) in place on top of the supports. Add water until the water level is $\frac{1}{8} \pm 0.01$ in. ($3.00[3.00 \pm 0.25\text{ mm}]3\text{ mm}$) above the top of the supports. When testing tile with scored bed surfaces, the depth of water level is $\frac{1}{8} \pm 0.01$ in. ($3.00 \pm 0.25\text{ mm}$) [$3.00 \pm 0.25\text{ mm}$] plus the depth of scores.

10.3.4 After removal of the reference brick, set the test brick in place flatwise, counting zero time as the moment of contact of the brick with the water. During the period of contact ($1\text{ min} \pm 1\text{ s}$) keep the water level within the prescribed limits by adding water as required. At the end of $1\text{ min} \pm 1\text{ s}$, lift the brick from contact with the water, wipe off the surface water with a damp cloth, and reweigh the brick to the nearest 0.5 g. Wiping shall be completed within 10 s of removal from contact with the water, and weighing shall be completed within 2 min.

NOTE 9—Place the brick in contact with the water quickly, but without splashing. Set the brick in position with a rocking motion to avoid the entrapping of air on its under surface. Test brick with frogs or depressions in one flatwise surface with the frog or depression uppermost. Test molded brick with the struck face down.

10.4 Calculation and Report:

10.4.1 The difference in weight in grams between the initial and final weighings is the weight in grams of water absorbed by the brick during 1-min contact with the water. When the area of its flatwise surface (length times width) does not differ more than $\pm 0.75\text{ in.}^2$ ($5[5\text{ cm}^2]$) ($\pm 2.5\%$) from 30 in.^2 ($200[200\text{ cm}^2]$), report the gain in weight of each specimen to the nearest 0.1 g, as its initial rate of absorption in 1 min.

10.4.2 When the area of its flatwise surface differs more than $\pm 0.75\text{ in.}^2$ ($5[5\text{ cm}^2]$) ($\pm 2.5\%$) from 30 in.^2 ($200[200\text{ cm}^2]$), calculate the equivalent gain in weight from 30 in.^2 ($200[200\text{ cm}^2]$) of each specimen to the nearest 0.1 g as follows:

$$X = 30 W/LB \text{ (metric } X = 200 W/LB) \quad (6)$$

where:

- \bar{X} = gain in weight corrected to basis of 30 in.^2 (200 cm^2) flatwise area,
- \underline{X} = gain in weight corrected to basis of 30 in.^2 [200 cm^2] flatwise area,
- W = actual gain in weight of specimen, g,
- \bar{L} = length of specimen, in., (cm), and
- \underline{L} = length of specimen, in., [cm], and
- \bar{B} = width of specimen, in., (cm), and
- \underline{B} = width of specimen, in., [cm].

10.4.3 Report the corrected gain in weight, X , of each specimen to the nearest 0.1 g, as the initial rate of absorption in 1 min.

10.4.4 When the test specimen is a cored brick, calculate the net area and substitute for LB in the equation given in 10.4.2. Report the corrected gain in weight, X , of each specimen to the nearest 0.1 g, as the initial rate of absorption in 1 min.

10.4.5 When the specimen is non-prismatic, calculate the net area by suitable geometric means and substitute for LB in the equation given in 10.4.2.

10.5 Calculate and report the average initial rate of absorption of all specimens tested to the nearest 0.1 g/min/ 30 in.^2 ($200[200\text{ cm}^2]$).

10.6 Report the method of drying as oven-dried (in accordance with 10.3.1.1) or ambient air-dried (in accordance with 10.3.1.2).

11. Efflorescence

11.1 Apparatus:

11.1.1 *Trays and Containers*—Watertight shallow pans or trays made of corrosion-resistant metal or other material that will not provide soluble salts when in contact with distilled water containing leachings from brick. The pan shall be of such dimensions

that it will provide not less than a 1-in. ~~(25-mm)~~[25-mm] depth of water. Unless the pan provides an area such that the total volume of water is large in comparison with the amount evaporated each day, suitable apparatus shall be provided for keeping a constant level of water in the pan.

11.1.2 *Drying Room*, conforming to the requirements of 9.1.6.

11.1.3 *Drying Oven*, conforming to the requirements of 9.1.4.

11.1.4 *Brush*, a soft-bristle brush.

11.2 *Test Specimens*:

11.2.1 The sample shall consist of ten full-size brick.

11.2.2 The ten specimens shall be sorted into five pairs so that both specimens of each pair are similar in appearance.

11.3 *Preparation of Specimens*—Remove by brushing any adhering dirt so as not to mistake it for efflorescence. Dry and cool the specimens in accordance with 5.1.

11.4 *Procedure*:

11.4.1 Set one specimen from each of the five pairs, on end, partially immersed in distilled water to a depth of approximately 1 in. ~~(25-mm)~~[25 mm] for 7 days in the drying room. When several specimens are tested in the same container, separate the individual specimens by a spacing of at least 2 in. ~~(50-mm)~~[50 mm].

NOTE 10—Do not test specimens from different sources simultaneously in the same container, because specimens with a considerable content of soluble salts will contaminate salt-free specimens.

NOTE 11—Empty and clean the pans or trays after each test.

11.4.2 Store the second specimen from each of the five pairs in the drying room without contact with water.

11.4.3 At the end of 7 days, inspect the first set of specimens and then place both sets in the drying oven without contact with water for 24 hours.

11.5 *Examination and Rating*—After drying, examine and compare each pair of specimens, observing the top and all four faces of each specimen from a distance of 10 ft. ~~(3-m)~~ft [3 m] under an illumination of not less than 50 footcandles ~~(540)~~[540 lm/m²] by an observer with normal vision. When under these conditions no difference is noted, report the rating as “not effloresced.” When a perceptible difference due to efflorescence is noted under these conditions, report the rating as “effloresced.” Report the appearance and distribution of the efflorescence.

11.6 *Precision and Bias*—No information is presented about either the precision or bias of the test method for efflorescence because the test result is nonquantitative.

12. Weight per Unit Area

12.1 *Apparatus*—A scale or balance sensitive to within 0.2 % of the weight of the smallest specimen.

12.2 *Procedure*—Weigh in accordance with 5.2 five full size structural clay tile units that have been dried and cooled (see 5.1).

12.3 *Calculation and Report*:

12.3.1 Calculate the weight per unit area of each specimen as follows:

$$W_a = \frac{nW_d}{A_{fa1} + A_{fa2}} \quad (7)$$

where:

W_a = weight per unit area of the specimen, lb/ft² (kg/m²),

W_a = weight per unit area of the specimen, lb/ft² [kg/m²],

n = number of faces of the specimen (1 for split tile units or 2 for all other units),

W_d = dry weight of the specimen, lb (kg),

W_d = dry weight of the specimen, lb [kg],

A_{fa1} = area (height × length) of finished face of specimen, ft² (m²), and

A_{fa1} = area (height × length) of finished face of specimen, ft² [m²], and

A_{fa2} = area (height × length) of back face of specimen, ft² (m²).

A_{fa2} = area (height × length) of back face of specimen, ft² [m²].

12.3.2 Report the results of Eq 7 separately for each specimen to the nearest 1 g and the average to the nearest 1 g for all specimens tested.

13. Measurement of Size

13.1 *Apparatus*—Either a 1-ft (or metric) steel rule, graduated in 1/32-in. (or 1-mm) divisions, or a gauge or caliper having a scale ranging from 1 to 12 in. ~~(25)~~[25 to 300 mm], mm], graduated in 1/1000 in. [0.05 mm] divisions, and having parallel jaws, shall be used for measuring the individual units. ~~Steel rules or calipers~~ Calipers of corresponding accuracy and size required shall be used for measurement of larger brick, solid masonry units, and tile.

NOTE 12—It is common in both the manufacturing process and in the field to assess unit size using a steel rule. However, for determination of

conformance to clay masonry unit standard specifications, the apparatus defined in 13.1 shall be used.

13.2 *Procedure*—Measure ten whole full-size units that have been dried and cooled (see 5.1). These units shall be representative of the lot and shall include the extremes of color range and size as determined by visual inspection. (It is permissible to use the same samples for determining efflorescence and other properties.)

13.3 *Individual Measurements of Width, Length, and Height*—Measure the width across both ends and both beds from the midpoints of the edges bounding the faces. Record these four measurements to the nearest $\frac{1}{100}$ in. (~~1 mm~~)[0.25 mm] and record the average to the nearest $\frac{1}{64}$ in. (~~0.5 mm~~)[0.5 mm] as the width. Measure the length along both beds and along both faces from the midpoints of the edges bounding the ends. Record these four measurements to the nearest $\frac{1}{100}$ in. (~~1 mm~~)[0.25 mm] and record the average to the nearest $\frac{1}{64}$ in. (~~0.5 mm~~)[0.5 mm] as the length. Measure the height across both faces and both ends from the midpoints of the edges bounding the beds. Record these four measurements to the nearest $\frac{1}{100}$ in. (~~1 mm~~)[0.25 mm] and record the average to the nearest $\frac{1}{64}$ in. (~~0.5 mm~~)[0.5 mm] as the height. Use the apparatus described in 13.1. Retest by the same method when required.

13.4 *Report*—Report the average width, length, and height of each specimen tested to the nearest $\frac{1}{32}$ in. (~~1.0 mm~~)[1.0 mm].

14. Measurement of Warpage

14.1 Apparatus:

14.1.1 Steel Straightedge:

14.1.2 *Rule or Measuring Wedge*—A steel rule graduated from one end in $\frac{1}{32}$ -in. (~~or 1 mm~~)[~~or 1 mm~~] divisions, or alternatively, a steel measuring wedge 2.5 in. (~~60 mm~~)[60 mm] in length by 0.5 in. (~~12.5 mm~~)[12.5 mm] in width by 0.5 in. (~~12.5 mm~~)[12.5 mm] in thickness at one end and tapered, starting at a line 0.5 in. (~~12.5 mm~~)[12.5 mm] from one end, to zero thickness at the other end. The wedge shall be graduated in $\frac{1}{32}$ -in. (~~or 1 mm~~)[~~or 1 mm~~] divisions and numbered to show the thickness of the wedge between the base, AB, and the slope, AC, Fig. 1.

14.1.3 *Flat Surface*, of steel or glass, not less than 12 by 12 in. (~~300~~[300 by 300 mm]mm) and plane to within 0.001 in. (~~0.025 mm~~)[0.025 mm].

14.1.4 *Brush*, a soft-bristle brush.

14.2 *Sampling*—Use the sample of ten units selected for determination of size.

14.3 *Preparation of Samples*—Test the specimens as received, except remove any adhering dirt by brushing.

14.4 Procedure:

14.4.1 *Concave Surfaces*—Where the warpage to be measured is of a surface and is concave, place the straightedge lengthwise or diagonally along the surface to be measured, selecting the location that gives the greatest departure from straightness. Select the greatest distance from the unit surface to the straightedge. Using the steel rule or wedge, measure this distance to the nearest $\frac{1}{32}$ in. (~~1 mm~~)[1 mm], and record as the concave warpage of the surface. See Fig. 2.

14.4.2 *Concave Edges*—Where the warpage to be measured is of an edge and is concave, place the straightedge between the ends of the concave edge to be measured. Select the greatest distance from the unit edge to the straightedge. Using the steel rule or wedge, measure this distance to the nearest $\frac{1}{32}$ in. (~~1 mm~~)[1 mm], and record as the concave warpage of the edge.

14.4.3 *Convex Surfaces*—When the warpage to be measured is of a surface and is convex, place the unit with the convex surface in contact with a plane surface and with the corners approximately equidistant from the plane surface. Using the steel rule or wedge, measure the distance to the nearest $\frac{1}{32}$ in. (1 mm) of each of the four corners from the plane surface. Record the average of the four measurements as the convex warpage of the unit.

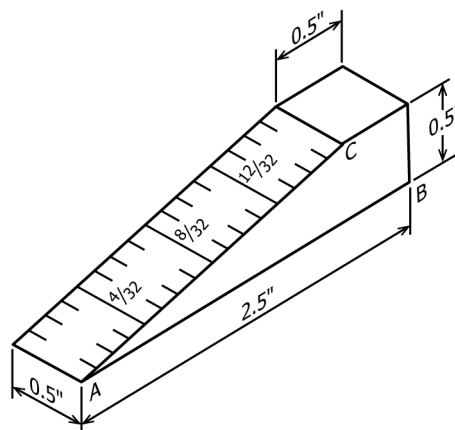

FIG. 1 Measuring Wedge