

---

---

**Small-bore connectors for liquids and  
gases in healthcare applications —**

**Part 7:  
Connectors for intravascular or  
hypodermic applications**

**iTeh STANDARD PREVIEW**  
**(standards.iteh.ai)**

*Raccords de petite taille pour liquides et gaz utilisés dans le domaine  
de la santé —*

*Partie 7: Connecteurs pour les applications intravasculaires ou  
hypodermiques*

ISO 80369-7:2021

<https://standards.iteh.ai/catalog/standards/sist/e8ac7d12-8325-46bc-843a-73b39c3f95f3/iso-80369-7-2021>



**iTeh STANDARD PREVIEW**  
**(standards.iteh.ai)**

ISO 80369-7:2021

<https://standards.iteh.ai/catalog/standards/sist/e8ac7d12-8325-46bc-843a-73b39c3f95f3/iso-80369-7-2021>



**COPYRIGHT PROTECTED DOCUMENT**

© ISO 2021

All rights reserved. Unless otherwise specified, or required in the context of its implementation, no part of this publication may be reproduced or utilized otherwise in any form or by any means, electronic or mechanical, including photocopying, or posting on the internet or an intranet, without prior written permission. Permission can be requested from either ISO at the address below or ISO's member body in the country of the requester.

ISO copyright office  
CP 401 • Ch. de Blandonnet 8  
CH-1214 Vernier, Geneva  
Phone: +41 22 749 01 11  
Email: [copyright@iso.org](mailto:copyright@iso.org)  
Website: [www.iso.org](http://www.iso.org)

Published in Switzerland

# Contents

	Page
Foreword.....	iv
Introduction.....	v
<b>1 Scope</b> .....	<b>1</b>
<b>2 Normative references</b> .....	<b>1</b>
<b>3 Terms and definitions</b> .....	<b>2</b>
<b>4 General requirements</b> .....	<b>3</b>
4.1 General requirements for <i>Luer connectors</i> .....	3
4.2 Type tests.....	3
<b>5 Dimensional requirements for <i>Luer connectors</i></b> .....	<b>3</b>
<b>6 Performance requirements</b> .....	<b>4</b>
6.1 Fluid leakage.....	4
6.1.1 Fluid leakage requirement.....	4
6.1.2 Leakage by pressure decay.....	4
6.1.3 Positive pressure liquid leakage.....	4
6.2 Sub-atmospheric pressure air leakage.....	4
6.3 Stress cracking.....	5
6.4 Resistance to separation from axial load.....	5
6.5 Resistance to separation from unscrewing.....	5
6.6 Resistance to overriding.....	5
<b>Annex A (informative) Rationale and guidance</b> .....	<b>6</b>
<b>Annex B (normative) <i>Luer connectors</i></b> .....	<b>10</b>
<b>Annex C (normative) Reference connectors</b> .....	<b>25</b>
<b>Annex D (informative) Assessment of medical devices and their attributes with connections within this application</b> .....	<b>32</b>
<b>Annex E (informative) Summary of the usability requirements for <i>Luer connectors</i> for intravascular or hypodermic applications</b> .....	<b>34</b>
<b>Annex F (informative) Summary of <i>Luer connector</i> design requirements for intravascular or hypodermic applications</b> .....	<b>38</b>
<b>Annex G (informative) Summary of assessment of the design of the <i>Luer connector</i> for intravascular or hypodermic applications</b> .....	<b>41</b>
<b>Annex H (informative) Reference to the essential principles</b> .....	<b>44</b>
<b>Annex I (informative) Reference to the general safety and performance requirements</b> .....	<b>45</b>
<b>Annex J (informative) Terminology — Alphabetized index of defined terms</b> .....	<b>46</b>
<b>Bibliography</b> .....	<b>47</b>

## Foreword

ISO (the International Organization for Standardization) is a worldwide federation of national standards bodies (ISO member bodies). The work of preparing International Standards is normally carried out through ISO technical committees. Each member body interested in a subject for which a technical committee has been established has the right to be represented on that committee. International organizations, governmental and non-governmental, in liaison with ISO, also take part in the work. ISO collaborates closely with the International Electrotechnical Commission (IEC) on all matters of electrotechnical standardization.

The procedures used to develop this document and those intended for its further maintenance are described in the ISO/IEC Directives, Part 1. In particular, the different approval criteria needed for the different types of ISO documents should be noted. This document was drafted in accordance with the editorial rules of the ISO/IEC Directives, Part 2 (see [www.iso.org/directives](http://www.iso.org/directives)).

Attention is drawn to the possibility that some of the elements of this document may be the subject of patent rights. ISO shall not be held responsible for identifying any or all such patent rights. Details of any patent rights identified during the development of the document will be in the Introduction and/or on the ISO list of patent declarations received (see [www.iso.org/patents](http://www.iso.org/patents)).

Any trade name used in this document is information given for the convenience of users and does not constitute an endorsement.

For an explanation of the voluntary nature of standards, the meaning of ISO specific terms and expressions related to conformity assessment, as well as information about ISO's adherence to the World Trade Organization (WTO) principles in the Technical Barriers to Trade (TBT), see [www.iso.org/iso/foreword.html](http://www.iso.org/iso/foreword.html).

This document was prepared by Technical Committee ISO/TC 210, *Quality management and corresponding general aspects for medical devices*, and IEC/SC62D, *Electromedical equipment*, in collaboration with the European Committee for Standardization (CEN) Technical Committee, CEN/CENELEC JTC3/WG 2, *Small-bore connectors*, in accordance with the Agreement on technical cooperation between ISO and CEN (Vienna Agreement).

This second edition cancels and replaces the first edition (ISO 80369-7:2016), which has been technically revised.

The main changes compared to the previous edition are as follows:

- Tolerances of several reference *connector* dimensions are increased to facilitate easier manufacturing and certification. Most of the affected tolerances are for features that do not contact the test *connector* and therefore do not affect the test results. The angle tolerance for the bearing side of the threads do contact the *connector* under test but the change in the tolerance is considered likely have minimal to no effect on test outcomes.
- Some requirements for *Luer connectors* have been separated for *semi-rigid materials* and *rigid materials* to better ensure compatibility at the extreme of the design space. Definitions of *semi-rigid material* and *rigid material* have been added.
- The distance from the tip of the *connector* to the bottom of the first complete thread profile of the internal thread (*t* dimension) has been made an *auxiliary dimension* due to the difficulty in its measurement. The functional impact of the dimension is evaluated with the resistance to separation (from axial load) functional test.
- The N1 and N2 dimensions of the female *Luer lock connector* variant A (with lugs at right angle to axis) have been changed to allow measurement from the open end of the *connector*, to better ensure compatibility at the extreme of the design space.

Any feedback or questions on this document should be directed to the user's national standards body. A complete listing of these bodies can be found at [www.iso.org/members.html](http://www.iso.org/members.html).

## Introduction

This document was developed because of several incidents, with catastrophic consequences, resulting from inappropriate medication, liquid nutritional formula or air being administered intravenously. Many incidents have been reported leading to international recognition of the importance of these issues and a need has been identified to develop specific *connectors* for *medical devices* and their *accessories* used to deliver fluids in other *applications*.

The ISO 80369 series was developed to prevent misconnection between *small-bore connectors* used in different *applications*. ISO 80369-1 specifies the requirements necessary to verify the designs and dimensions of *small-bore connectors* to ensure that

- a) they do not misconnect with other *small-bore connectors*, and
- b) they safely and securely connect with their mating half.

This document specifies the design and the dimensions and the drawings of *small-bore connectors* intended to be used as conical fittings with a 6 % (Luer) taper for *connections* in intravascular or hypodermic *applications*. [Annex D](#) to [Annex G](#) describe the methods by which this design has been assessed. Other parts of ISO 80369 include requirements for *small-bore connectors* used in different *application* categories.

*Connectors* manufactured to the dimensions set out within this document are dimensionally incompatible with any of the other *connectors* for *applications* identified in the ISO 80369 series of documents for *small-bore connectors*, except as indicated in [Annex G](#). If fitted to the relevant *medical devices* and *accessories*, these *connectors* should reduce the *risk* of air, non-vascular medication and liquid nutritional formula being delivered through an alternative route, such as intravenously or through an airway device.

In this document, the conjunctive “or” is used as an “inclusive or” so a statement is true if any combination of the conditions is true.

In this document, the following verbal forms are used:

- “shall” indicates a requirement;
- “should” means that conformance with a requirement or a test is recommended but is not mandatory for conformance with this document;
- “may” indicates a permission;
- “can” indicates a possibility or a capability.

**iTeh STANDARD PREVIEW**  
**(standards.iteh.ai)**

ISO 80369-7:2021

<https://standards.iteh.ai/catalog/standards/sist/e8ac7d12-8325-46bc-843a-73b39c3f95f3/iso-80369-7-2021>

# Small-bore connectors for liquids and gases in healthcare applications —

## Part 7: Connectors for intravascular or hypodermic applications

### 1 Scope

This document specifies dimensions and requirements for the design and functional performance of *small-bore connectors* intended to be used for *connections* in intravascular *applications* or hypodermic *connections* in hypodermic *applications* of *medical devices* and *accessories*.

EXAMPLES Hypodermic syringes and needles or intravascular (IV) cannulae with male and female *Luer slip connectors* and *Luer lock connectors*.

NOTE 1 See [Annex A](#).

NOTE 2 The *Luer connector* was originally designed for use at pressures up to 300 kPa.

This document does not specify requirements for the *medical devices* or *accessories* that use these *connectors*. Such requirements are given in particular documents for specific *medical devices* or *accessories*.

This document does not specify requirements for the following *small-bore connectors*, which are specified in other documents:

- haemodialyser, haemodiafilter and haemofilter blood compartment ports (ISO 8637 [5] and applicable portion of ISO 8638 [6] referencing blood compartment ports);
- haemodialysis, haemodiafiltration and haemofiltration equipment *connectors* (ISO 8637 [5]);
- infusion system closure piercing *connectors* (ISO 8536-4 [4]).

NOTE 3 *Manufacturers* are encouraged to incorporate the *small-bore connectors* specified in this document into *medical devices* or *accessories*, even if currently not required by the relevant particular *medical device* documents. It is expected that when the relevant particular *medical device* documents are revised, requirements for *small-bore connectors*, as specified in ISO 80369, will be included.

NOTE 4 ISO 80369-1:2018, Clause 7, specifies alternative methods of conformance with ISO 80369-1:2018, for *small-bore connectors* intended for use with intravascular *applications* or hypodermic *application medical devices* or *accessories*, which do not conform with this document.

### 2 Normative references

The following documents, in whole or in part, are normatively referenced in this document and are indispensable for its application. For dated references, only the edition cited applies. For undated references, the latest edition of the referenced document (including any amendments) applies.

ISO 14971:2019, *Medical devices — Application of risk management to medical devices*

ISO 80369-1:2018, *Small-bore connectors for liquids and gases in healthcare applications — Part 1: General requirements*

ISO 80369-6:2016, *Small bore connectors for liquids and gases in healthcare applications — Part 6: Connectors for neuraxial applications*

ISO 80369-20:2015, *Small-bore connectors for liquids and gases in healthcare applications — Part 20: Common test methods*

IEC 62366-1:2015, *Medical devices — Part 1: Application of usability engineering to medical devices*

### 3 Terms and definitions

For the purposes of this document, the terms and definitions specified in ISO 80369-1:2018, ISO 80369-20:2015, ISO 14971:2019, IEC 62366-1:2015 as indicated in [Annex J](#) and the following apply.

NOTE For convenience, the sources of all defined terms used in this document are given in [Annex J](#).

— ISO Online browsing platform: available at <https://www.iso.org/obp>

— IEC Electropedia: available at <http://www.electropedia.org/>

#### 3.1

##### **auxiliary dimension**

dimension derived from other dimensions given for information purposes only

[SOURCE: ISO 10209:2012<sup>[2]</sup>, 4.2]

#### 3.2

##### **Luer connector**

*small-bore connector* that contains a conical mating surface with a 6 % (Luer) taper intended for use in intravascular or hypodermic applications of medical devices and related accessories

Note 1 to entry: A *Luer connector* can be either a *Luer slip connector* or a *Luer lock connector*.

Note 2 to entry: See [Annex A](#).

#### 3.3

##### **Luer slip connector**

*Luer connector* without a lock

Note 1 to entry: The *Luer slip connector* is indicated by the abbreviation L1.

Note 2 to entry: See [Annex A](#).

#### 3.4

##### **Luer lock connector**

*Luer connector* that contains a locking mechanism

Note 1 to entry: The *Luer lock connector* is indicated by the abbreviation L2.

Note 2 to entry: See [Annex A](#).

#### 3.5

##### **normal use**

operation, including routine inspection and adjustments by any *user*, and stand-by, according to the instructions for use

Note 1 to entry: *Normal use* should not be confused with *intended use*. While both include the concept of use as intended by the *manufacturer*, *intended use* focuses on the medical purpose while *normal use* incorporates not only the medical purpose, but maintenance, service, transport, etc. as well.

[SOURCE: IEC 60601-1:2005+A1:2012 <sup>[12]</sup>, 3.71, modified — replaced “operator” with “user”.]

#### 3.6

##### **rated**

<value> term referring to a value assigned by the *manufacturer* for a specified operating condition

[SOURCE: IEC 60601-1:2005 <sup>[12]</sup>, 3.97]



**3.7*****rigid material***

material with a modulus of elasticity either in flexure or in tension greater than 3 433 MPa

EXAMPLE Metals, glass, some fibre-reinforced polymers and high-performance polymers.

**3.8*****semi-rigid material***

material with a modulus of elasticity either in flexure or in tension, between 700 MPa and 3 433 MPa

EXAMPLE Thermoplastics.

**4 General requirements****4.1 General requirements for *Luer connectors***

*Luer connectors* made in conformance with this document conform with the general requirements of ISO 80369-1:2018, unless otherwise indicated in this document.

In some tolerance combinations, the inside diameter of the fluid lumen of male *Luer connector* may contact the sealing surfaces of the N1 male *connector* (N1), as specified in ISO 80369-6, in *LMC* and thereby these *connectors* mutually fail when evaluating the *non-interconnectable* characteristics tests of ISO 80369-1:2018, Annex B. Additional information is provided in [G.2.2](#).

The reference *connectors* for evaluation of the *non-interconnectable* characteristics are described in [Annex C](#) ([Figures C.1](#), [C.2](#), [C.4](#) and [C.5](#), as appropriate).

Where a *medical device* or *accessory* is designed to provide features of the *Luer connector* of this document, those features shall be included in the *verification* to this document. When necessary, install the *small-bore connector* on the *medical device* or *accessory* to demonstrate conformance with ISO 80369-1:2018, [Annex B](#).

NOTE 1 The summary of *medical devices* and their attributes with *connections* within this *application* is provided in [Annex D](#).

NOTE 2 The summary of the *usability* requirements for *Luer connectors* is provided in [Annex E](#).

NOTE 3 The summary of *Luer connectors* criteria and requirements is provided in [Annex F](#).

NOTE 4 The summary of assessment of the design of *Luer connectors* according to ISO 80369-1:2018, 6.1, is contained in [Annex G](#).

NOTE 5 This document has been prepared to address the relevant essential principles of safety and performance of ISO 16142-1:2016 <sup>[9]</sup> as indicated in [Annex H](#).

NOTE 6 This document has been prepared to address the relevant general safety and performance requirements of European regulation (EU) 2017/745 <sup>[15]</sup> as indicated in [Annex I](#).

**4.2 Type tests**

Conformance with the requirements of this document shall be determined by *type tests*.

**5 Dimensional requirements for *Luer connectors***

*Luer connectors* shall conform with the dimensions and tolerances as given in

- [Figure B.1](#) and [Table B.1](#) for a male *Luer slip connector* (L1),
- [Figure B.2](#) and [Table B.2](#) for a female *Luer slip connector* (L1),
- [Figure B.3](#) and [Table B.3](#) for a male *Luer lock connector* (L2), with fixed collar,

- [Figure B.4](#) and [Table B.4](#) for a male *Luer lock connector* (L2), with floating or rotatable collar,
- [Figure B.5](#) and [Table B.5](#) for a female *Luer lock connector* (L2),
- [Figure B.6](#) and [Table B.6](#) for a female *Luer lock connector* (L2), with lugs at right angle to axis, variant A,
- [Figure B.7](#) and [Table B.7](#) for a female *Luer lock connector* (L2), with lugs at right angle to axis, variant B, and
- [Figure B.8](#) and [Table B.8](#) for a female *Luer lock connector* (L2), with lugs at right angle to axis, variant C.

Check conformance by confirming the dimensions and tolerances specified in [Annex B](#), for the appropriate figure and table.

NOTE See [Annex A](#).

## 6 Performance requirements

### 6.1 Fluid leakage

#### 6.1.1 Fluid leakage requirement

*Luer connectors* shall be evaluated for leakage using either the leakage by pressure decay *test method* or the positive pressure liquid leakage *test method*.

#### 6.1.2 Leakage by pressure decay

*Luer connectors* evaluated for fluid leakage performance with the leakage by pressure decay *test method* shall not exceed a leakage rate of  $0,005 \text{ Pa}\cdot\text{m}^3/\text{s}$  while being subjected to an applied pressure of between 300 kPa and 330 kPa over a hold period between 15 s and 20 s using air as the medium.

Check conformance by applying the tests of ISO 80369-20:2015, Annex B, while using the leakage reference *connector* specified in [Annex C](#) ([Figures C.1](#), [C.2](#), [C.4](#) and [C.5](#), as appropriate). A greater applied pressure may be used.

#### 6.1.3 Positive pressure liquid leakage

*Luer connectors* evaluated for fluid leakage performance with the positive pressure liquid leakage *test method* shall show no signs of leakage, sufficient to form a falling drop of water, over a hold period of 30 s to 35 s while being subjected to an applied pressure of between 300 kPa and 330 kPa.

Check conformance by applying the tests of ISO 80369-20:2015, Annex C, while using the leakage reference *connector* specified in [Annex C](#) ([Figures C.1](#), [C.2](#), [C.4](#) and [C.5](#), as appropriate). A greater applied pressure may be used.

### 6.2 Sub-atmospheric pressure air leakage

*Luer connectors* shall be evaluated for sub-atmospheric pressure air leakage. *Luer connectors* shall not leak by more than  $0,005 \text{ Pa}\cdot\text{m}^3/\text{s}$  while being subjected to an applied sub-atmospheric pressure of between 80,0 kPa and 88,0 kPa over a hold period of between 15 s and 20 s.

Check conformance by applying the tests of ISO 80369-20:2015, Annex D, while using the leakage reference *connector* specified in [Annex C](#) ([Figures C.1](#), [C.2](#), [C.4](#) and [C.5](#), as appropriate). A greater applied sub-atmospheric pressure may be used.

### 6.3 Stress cracking

*Luer connectors* shall be evaluated for stress cracking. *Luer connectors* shall meet the requirements of [6.1.1](#) after being subjected to stresses of ISO 80369-20:2015, Annex E.

Check conformance by applying the tests of ISO 80369-20:2015, Annex E, while using the stress cracking reference *connector* specified in [Annex C](#) ([Figures C.1](#), [C.2](#), [C.4](#) and [C.5](#), as appropriate).

### 6.4 Resistance to separation from axial load

*Luer connectors* shall be evaluated for separation from axial load. *Luer connectors* shall not separate from the reference *connector* over a hold period between 10 s and 15 s while being subjected to a disconnection applied axial force between

- a) 23 N and 25 N for *Luer slip connectors*, and
- b) 32 N and 35 N for *Luer lock connectors*.

Check conformance by applying the tests of ISO 80369-20:2015, Annex F, while using the resistance to separation from axial load reference *connector* specified in [Annex C](#) ([Figures C.2](#), [C.3](#), [C.5](#) and [C.6](#), as appropriate). A greater disconnection applied axial force or a longer hold period may be used.

### 6.5 Resistance to separation from unscrewing

*Luer lock connectors* shall be evaluated for separation from unscrewing. *Luer lock connectors* shall not separate from the reference *connector* for a hold period between 10 s and 15 s while being subjected to an unscrewing torque of between 0,018 N·m to 0,020 N·m.

Check conformance by applying the tests of ISO 80369-20:2015, Annex G, while using the resistance to separation from unscrewing reference *connector* specified in [Annex C](#) ([Figures C.1](#) and [C.4](#), as appropriate). A greater applied unscrewing torque or a longer hold period may be used.

### 6.6 Resistance to overriding

*Luer lock connectors* shall be evaluated for resistance to overriding. *Luer lock connectors* shall not override the threads or lugs of the reference *connector* while being subjected to an applied torque of between 0,15 N·m to 0,17 N·m over a hold period between 5 s and 10 s.

Check conformance by applying the tests of ISO 80369-20:2015, Annex H, while using the resistance to overriding reference *connector* specified in [Annex C](#) ([Figures C.3](#) and [C.6](#), as appropriate). A greater applied torque or a longer hold period may be used.

## Annex A (informative)

### Rationale and guidance

#### A.1 General guidance

This annex provides a rationale for some requirements of this document and is intended for those who are familiar with the subject of this document but who have not participated in its development. An understanding of the rationale underlying these requirements is considered to be essential for their proper use. Furthermore, as clinical practice and technology change, it is believed that a rationale will facilitate any revision of this document necessitated by those developments.

#### A.2 Rationale for particular clauses and subclauses

The clauses and subclauses in this Annex have been numbered to correspond to the numbering of the clauses and subclauses of this document to which they refer. The numbering is, therefore, not consecutive.

##### Clause 1 Scope

The scope includes the fittings described previously in ISO 594-1 and ISO 594-2.

In 2000, a Task Group of the European standards organization CEN proposed a strategy to reduce incidents of accidental misconnection of *patient* therapy lines by the use of a series of *non-interconnectable connectors*, differentiated by design, for use in different medical applications. The strategy reserves the use of *Luer connectors* solely for use in *medical devices* used to access the vascular system or for hypodermic applications so that they can achieve their intended function [14].

During the development of this document, the committees frequently debated how *Luer connector* activated *medical devices* (LADs) should be interpreted. In context of this document, “LADs” are considered to be a “component” of the *medical device* and are typically a female valve designed to interconnect with male *Luer connector*. The following guidance relates specifically to the LAD (or female valve end) component only and does not include the rest of a *medical device*.

A LAD typically includes a valve that opens and permits access to the fluid conduit when a standard male *Luer connector* is inserted into it. By design, it forms one-half of the *connection* that establishes a fluid conduit with a male *Luer connector*. However, such LADs typically do not conform with this document. Specifically, they often are made of materials that are softer than *semi-rigid materials* (since their mating surfaces often include elastomeric materials) nor do they fully conform dimensionally to [Clause 5](#). Thus, a typical LAD is not a *Luer connector*. As such, they are not within the scope of this document.

The committees, however, felt compelled to provide some guidance on the LAD due to the obvious similarities of intended use with *Luer connectors*. It is advisable that *manufacturers* of LADs utilize the features providing *non-interconnectable* characteristics of this document, wherever possible, to address the *risk* of misconnections to their *medical devices*. These elements can include the appropriate combinations of the following:

- materials conformance (i.e.  $\geq 700$  MPa) for interference features;
- dimensional conformance (i.e. dimensions *H*, *J*, *D*, and *G* from [Annex B](#));
- dimensional and/or CAD analysis showing interference features;

- *non-interconnectable* characteristics testing per ISO 80369-1:2018, Annex B;
- usability testing demonstrating *non-interconnectable* characteristics.

Additionally, the functional performance requirements of [Clause 6](#) should also be considered for the LAD component.

In this way, the LADs can be evaluated for both *non-interconnectable* characteristics and performance characteristics associated with the ISO 80369 series.

The LADs by definition continue to not be considered a "conforming" *Luer connector* (i.e. not conforming with this document), however they can be considered 'compatible with' a *medical device* utilizing a male *Luer connector* (by way of functional performance).

*Manufacturers* and *responsible organizations* are encouraged to report their experience with the *Luer connectors* specified in this document to the Secretariat of ISO/TC 210, so that it can consider this feedback during the revision of the relevant part of the ISO 80369 series.

**Definition 3.2** *Luer connector*

**Definition 3.3** *Luer slip connector*

**Definition 3.4** *Luer lock connector*

For clarity, the new terms *Luer connector*, *Luer slip connector*, and *Luer lock connector* replace conflicting and confusing terms used in ISO 594-1 and ISO 594-2. The new terms align and harmonize this document with ISO 80369-1, which does not utilize the legacy terms fitting, conical, or taper. The new terms are equivalent to those now generically used to describe the *small-bore connectors* commonly named after their inventor, 19th century German medical instrument maker Hermann Wülfig Luer.

## **Clause 5 Dimensional requirements for *Luer connectors***

Legacy Luer gauges cannot be used to verify the performance of *connectors* that are intended to prevent misconnection because they lack the dimensions for surfaces not intended to form *connections* with *Luer connectors*. Maintenance of production quality (i.e. using gauges) is outside the scope of this document. The dimensional requirements in [Annex B](#) are a more precise description of the design and performance characteristics for both intended *connections* and avoidance of misconnections.

Dimensions and tolerances not previously identified in ISO 594-1 and ISO 594-2 are added to this document to reduce the *risk* of misconnections between *medical devices* or between *accessories* for different *applications* with non-*Luer connectors* that are being developed under other parts of the ISO 80369 series. These new requirements were selected to represent the inherent design and dimensions of *Luer connectors* in clinical use at the time this document was developed.

Since the configurations of the *connectors* proposed within this document are *small-bore connectors* with or without a threaded collar, the requirements and parameters from ISO 594-1 and ISO 594-2 have been used where applicable.

The maximum inside diameter at the tip of the male taper (through bore),  $\emptyset f$ , of 2,900 mm was chosen to describe the majority of *Luer connectors* available to *users* at the time of publication of this document. The committees considered the clinical needs of high flow rate intravascular *medical devices* and determined that the incremental increase in flow if  $\emptyset f$  is increased to a theoretical sharp edge of 3,50 mm was not warranted in view of the increased *risk* of misconnection with smaller male *small-bore connectors* in the ISO 80369 series.

Commercially developed glass prefilled syringes [8] routinely mate with *Luer connector* equipped *medical devices* in order to effectively administer the medication stored within the syringe. Examples: disposable needles, needleless ports and other forms of Luer access. Current state-of-technology syringe tip glass forming technology for manufacturing glass-prefilled syringes cannot conform completely to either previous Luer fitting standard, ISO 594 or this document. Both the previous standard and this document have been developed using ground glass, metal and injection moulded technology and plastic resins as the baseline for conformance and capabilities.



The minimum inside diameter at the tip of the male taper (through bore),  $\emptyset f$ , is not defined to accommodate the very small bore of glass syringes.

The committees acknowledge the differences in the manufacturing methodologies and the need for expanded tolerances in the glass forming manufacturing *process*. The baseline specifications of the tapered tip need to remain similar. However, to accommodate the glass forming manufacturing *process*, there needs to be expanded dimensional tolerances. While these tolerances are outside of the range of this document with respect to some of the dimensions, a glass formed tip does successfully mate with the injection moulded female *Luer connectors*. Refer to ISO 11040-4 [8] for a listing of those critical dimensions, their expanded corresponding tolerances and functional *test methods* that accommodate the formed tip manufacturing *process*.

A dimensional analysis of the female *Luer lock connector* (L2), variant A thread form was conducted during the development of this document to ensure both

- proper connection to other male *Luer connectors*, and
- prevention of misconnection to the other *connectors* of the ISO 80369 series.

The analysis demonstrated that in certain instances the thread form detailed in [Figure B.6](#) and [Table B.6](#) could, if taken to certain extremes, collide with non-sealing features of the mating male *Luer connector* (i.e. [Figure B.3](#) and [Figure B.4](#)) prior to a fluid tight seal being achieved. Specifically, the diagonal distance between the corners of the right-angle thread of the female *Luer lock connector* of [Figure B.6](#) could bind between adjacent threads of the mating male *Luer connector*. [Figure A.1](#) and [Figure A.2](#) illustrate this possible interference. This can be worsened by the allowable variations in thread profile, thread pitch and thread lead, of the features of the mating male *Luer connector*. This situation is unchanged from the legacy ISO 594-2, the same magnitude of interference was possible with conforming *connectors*.

Due to the proliferation of existing *Luer connectors* and general lack of data indicating a problem in use, the committees determined that the same level of interference would be permitted by this document (i.e. the permissible design is unchanged).

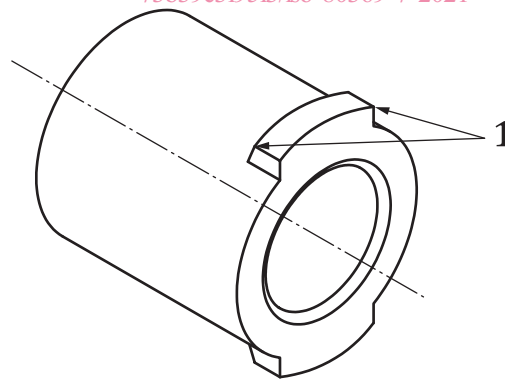

- Key**
- 1 corners that can interfere

**Figure A.1 — Lug corners that can interfere**

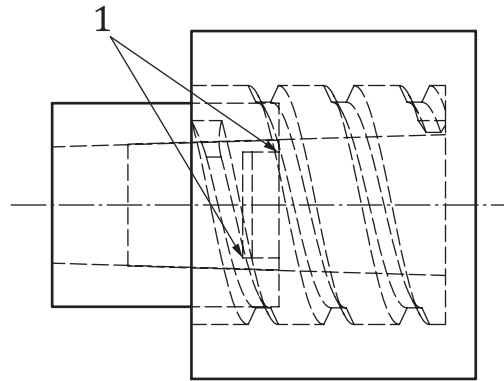
**Key**

1 area of potential interfere

**Figure A.2 — Area of potential interference**

The analysis also demonstrated that in certain instances the taper surfaces of male and female *Luer lock connectors* made from *semi-rigid materials*, if taken to certain extremes, might not engage deep enough to allow the threads to engage properly. In these instances, the resulting *connection* is only equal to a *Luer slip connector* and does not benefit from the additional retention of the locking threads. This potential is mitigated by the deformability of the *semi-rigid materials* from which most *connectors* are made that allow the tapers to engage further as they deform as they are connected. There is a general lack of data indicating a problem in actual use. For these reasons the dimensions have not been changed to eliminate this potential, but a newly recommended (informative) minimum value for the  $\varnothing D$  and  $\varnothing G$  dimensions has been added. Conforming with this recommendation reduces the likelihood of this possibility. All *connectors* are still required to conform with the resistance to separation from axial load functional test of 6.4.

The distance from the tip of the *connector* to the bottom of the first complete thread profile of the internal thread, the  $t$  dimension, is also essential for an effective locking *connection*. It has also been noted that there is a general lack of data indicating there is a problem even when many of the current male *Luer lock connectors* on the market made from *semi-rigid materials* do not meet the ideal maximum dimension of 3,200 mm. For this reason, combined with the difficulty in measuring this feature, the recommended dimension for *connectors* made from *semi-rigid materials* has changed and have been made an *auxiliary dimension*. All *connectors* are still required to conform with the resistance to separation from axial load functional test of 6.4.

In addition, due to the commercial evolution of existing *Luer connectors*, a *connector* conforming with ISO 594-2:1988, Figure 3, Variant A (female *Luer connector* with thread lug at right angle) was elusive to locate for testing purposes. Most participating *manufacturers*, who offer a “lug” version of threads, offer a version that has one side at a right angle with the other inclined at pitch “ $p$ ”, thus these are a hybrid between the traditional ISO 594-2:1988, Figure 3, Variant A and ISO 594-2:1988, Figure 4. Since the diameters provide the features that ensure the *non-interconnectable* characteristics are maintained, the committees decided to permit these hybrid thread lugs with the inclusion of features  $N1$  and  $N2$  (width of the thread lug at the root of the leading and trailing ends, respectively).

**NOTE** The same level of interference as described above (with threads at right angles) is possible within the tolerances specified. Each *manufacturer* is encouraged to check the performance of their design to ensure the *risk* of leakage is minimized.