

INTERNATIONAL STANDARD

ISO 4475

First edition
1989-07-01

Coniferous and broadleaved tree sawlogs — Visible defects — Measurement

*Billes à sciages de bois résineux et feuillus — Défauts apparents — Relevés et
mesurages*

iTeh STANDARD PREVIEW
(standards.iteh.ai)

ISO 4475:1989

[https://standards.iteh.ai/catalog/standards/sist/bc1ec6c0-5939-4fe0-9596-
b58a5a2bdfec/iso-4475-1989](https://standards.iteh.ai/catalog/standards/sist/bc1ec6c0-5939-4fe0-9596-b58a5a2bdfec/iso-4475-1989)

INTERNATIONAL

ISO



Reference number
ISO 4475 : 1989 (E)

Foreword

ISO (the International Organization for Standardization) is a worldwide federation of national standards bodies (ISO member bodies). The work of preparing International Standards is normally carried out through ISO technical committees. Each member body interested in a subject for which a technical committee has been established has the right to be represented on that committee. International organizations, governmental and non-governmental, in liaison with ISO, also take part in the work.

Draft International Standards adopted by the technical committees are circulated to the member bodies for approval before their acceptance as International Standards by the ISO Council. They are approved in accordance with ISO procedures requiring at least 75 % approval by the member bodies voting.

International Standard ISO 4475 was prepared by Technical Committee ISO/TC 55, *Sawn timber and sawlogs*.

Users should note that all International Standards undergo revision from time to time and that any reference made herein to any other International Standard implies its latest edition, unless otherwise stated.

iTeh STANDARD PREVIEW
(standards.iteh.ai)

ISO 4475:1989
<https://standards.iteh.ai/catalog/standards/sist/bc1cc0c0-5939-4fe0-9596-b58a5a2bdfec/iso-4475-1989>

© ISO 1989

All rights reserved. No part of this publication may be reproduced or utilized in any form or by any means, electronic or mechanical, including photocopying and microfilm, without permission in writing from the publisher.

International Organization for Standardization
Case postale 56 • CH-1211 Genève 20 • Switzerland

Printed in Switzerland

Coniferous and broadleaved tree sawlogs — Visible defects — Measurement

Scope and field of application

This International Standard applies to coniferous and broadleaved tree sawlogs and specifies the methods of measuring visible defects of sawlogs as classified in ISO 4473, *Coniferous and broadleaved tree sawlogs — Visible defects — Classification*, and ISO 4474, *Coniferous and broadleaved tree sawlogs — Visible defects — Terms and definitions*.

It is permitted to measure only one of the indicated parameters.

Frost crack or shake caused by lightning shall be measured as the minimum thickness of the out-cut in which it can be inserted; it is expressed in linear measures or as a fraction of the end diameter [see figure 3a), dimension a_1].

Measurement

NOTE — Where linear measurement is specified, this always refers to whole centimetres rounded off to the nearest centimetre below.

1 Knot

1.1 Flush knots (sound, unsound and rotten) shall be measured by the minimum diameter (see figure 1, dimension a). The knot callus is not included in the size of a knot.

1.2 Overgrown protruding knots are not measured but their presence shall be noted.

2 Shake

2.1 The end shake (heart shake and ring shake) shall be measured by the minimum thickness of the out-cut in which it can be inserted; it is expressed in linear measures or as a fraction of the end diameter (see figure 2).

Compound (star) heart shake shall be measured by the width and length of each shake and by counting their number.

Ring shake in broadleaved tree sawlogs is not measured but its presence shall be noted.

2.2 Side shake (frost crack, shake caused by lightning, drying shake and shallow, deep and through shake) shall be measured by the depth at the end and the length on the side surface of the log; it is expressed as a fraction of the diameter or in linear measures at the end and in linear measures on the side surface [see figures 3a) and 3b), dimensions b_1 , b_2 , c_1 and c_2 respectively].

3 Defects of trunk shape

3.1 Curvature

3.1.1 Simple curvature shall be measured

— as the deviation from straightness over the length of a piece at the point of its maximum bend; it is expressed as a percentage of the length of the curvature or as a fraction of the upper end diameter [see figure 4a), dimension z_1];

— as the deviation from straightness in the length of a piece over a 1 m length of the maximum bend.

3.1.2 Compound curvature shall be measured

— as the deviation from straightness over the length of a piece at the point of its maximum bend; it is expressed as a percentage of the length of the curvature or as a fraction of the upper end diameter [see figure 4b), dimension z_2]. In addition, the number of curves and whether they are in one or several planes shall be indicated. If necessary, each curve shall be measured and the total deviation calculated;

— as the deviation from straightness in the length of a piece over a 1 m length of the maximum bend.

When measuring simple and compound curvature at the lower end of butt-end logs, the size of taper on the first metre from the end shall be disregarded.

3.2 Knob

The knob shall be measured according to its length and height; it is expressed in linear measures, or as a function of the corresponding log dimensions (see figure 5, dimensions a , b or z_1 , z_2 respectively).

3.3 Root swelling

3.3.1 The round root swelling shall be measured by the difference between the average butt-end diameter, a_1 , and the average diameter measured 1 m from the butt-end, b_1 ; it is expressed in linear measures, z_1 , or as a function of the average diameter 1 m from the butt-end, z_2 (see figure 6).

3.3.2 The veined root swelling shall be measured by the difference between the diameter of the circumscribed circle at the butt-end, a_2 , and the diameter of the circumscribed circle measured 1 m from the butt-end, b_2 ; it is expressed in linear measures [see figure 6b), dimension z_3].

The veined root swelling may also be measured by the difference between the diameters of the circumscribed and inscribed circles at the butt-end (a_2 and c respectively); it is expressed in linear measures [see figure 6b), dimension z_4].

3.4 Ovality

Ovality shall be measured by the difference between the greater and lesser diameters of the corresponding log end; it is expressed in linear measures or by correlation of these diameters.

3.5 Tapering

Tapering shall be measured by the difference between the diameters of the upper and lower ends related to the log length; it is expressed in centimetres per metre of length, or as a percentage.

With butt-end logs, the lower end of the log shall be measured at a distance of 1 m from the lower end.

4 Defects of wood structure

4.1 Slope of grain shall be measured in the most typical zone on the side surface of the log over a length of 1 m, as the deviation of grain from a line parallel to the longitudinal axis of the log, i.e. by bark grooves on unbarked logs [see figure 7a)], or wood grains on barked logs [see figure 7b)]; it is expressed as a percentage or in linear measures (see figure 7, dimensions z_1 and z_2 respectively).

With butt-end logs, the slope of grain shall be measured not closer than 1 m to the lower end.

4.2 Reaction wood is not measured, but its presence shall be noted.

4.3 Double pith is not measured, but its presence shall be noted.

4.4 Removed pith shall be measured as the maximum deviation of the pith from the geometric centre of the end; it is expressed in linear measures or as a percentage of the mean diameter of the corresponding end of the log.

4.5 Scar shall be measured as the maximum depth, width and length; it is expressed in linear measures or as a function of the corresponding log dimensions (see figure 8, dimensions a , b and c respectively).

4.6 Inbark shall be measured

— as the minimum thickness of the out-cut in which it can be inscribed; it is expressed in linear measures or as a function of the diameter of the affected end (see figure 9, dimension a);

— as the depth or length depending on whether it is opened or closed; it is expressed in linear measures or as a function of the corresponding log dimensions (see figure 9, dimensions b and c).

4.7 Cancer is not measured, but its presence shall be noted.

4.8 False heartwood shall be measured

— as the minimum thickness of the out-cut in which it can be inscribed; it is expressed in linear measures or as a fraction of the end diameter (see figure 10, dimension a);

— as the area affected; it is expressed as a percentage of the area of the affected end.

4.9 Heart sapwood shall be measured as the exterior diameter and the width of its annulus; it is expressed in linear measures or as a fraction of the end diameter (see figure 11, dimensions d and a).

5 Defects caused by fungi

5.1 Fungal heartwood stains and streaks, heartwood rot and hollow shall be measured

— as the area affected; they are expressed as a percentage of the area of the affected end;

— as the minimum thickness of the out-cut in which they can be inscribed; they are expressed in linear measures or as a fraction of the end diameter [see figures 12a), 12b), 12c) and 12d), dimensions a_1 , a_2 , a_3 and a_4].

5.2 Fungal sap coloration, suffocated wood and sap rot shall be measured on the end

— as the depth of the end area affected from the side surface; they are expressed in linear measures or as a function of the corresponding dimension of the log (see figure 13, dimensions a_1 and a_2). With unbarked logs it is also possible to measure them as the length affected (see figure 13, dimension c);

— as the area affected; they are expressed as a percentage of the end area or of the area of sapwood at the affected end.

6 Damage

6.1 Damage caused by insects

6.1.1 Surface insect-holes are not measured, but their presence shall be noted.

6.1.2 Shallow insect-holes and deep insect-holes shall be distinguished by their varieties and shall be measured

- in case of mass local damage, by the length of the area affected,
- in case of individual large insect-holes, by their number per metre length of the log.

6.2 Damage caused by parasitic plants and damage caused by birds

Damage caused by parasitic plants or birds is not measured, but its presence and/or area shall be noted.

6.3 Alien inclusion

Alien inclusion is not measured, but its presence shall be noted.

6.4 Char

Char shall be measured as the depth, width and length of the area affected; it is expressed in linear measures or as a function of the corresponding log dimensions (see figure 14, dimensions *a*, *b* and *c* respectively).

6.5 Mechanical damage

6.5.1 Bark shelling shall be measured as the width and length of the area affected; it is expressed in linear measures or as a function of the corresponding log dimensions.

6.5.2 Blaze shall be measured as the depth, width and length; it is expressed in linear measures or as a function of the corresponding log dimensions (see figure 8, dimensions *a*, *b* and *c* respectively).

6.5.3 Incision and saw-cut shall be measured as the depth; they are expressed in linear measures or as a function of the corresponding log dimensions.

6.5.4 Off-chip, shear and extraction shall be measured as the thickness, width and length; they are expressed in linear measures or as a function of the corresponding log dimensions.

iTeh STANDARD PREVIEW (standards.iteh.ai)

ISO 4475:1989

<https://standards.iteh.ai/catalog/standards/sist/bc1ec6c0-5939-4fe0-9596-b58a5a2bdfec/iso-4475-1989>

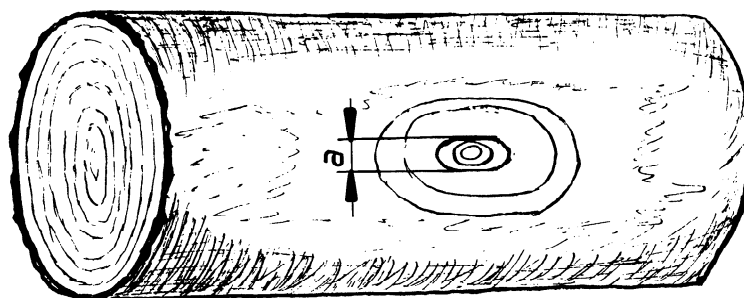
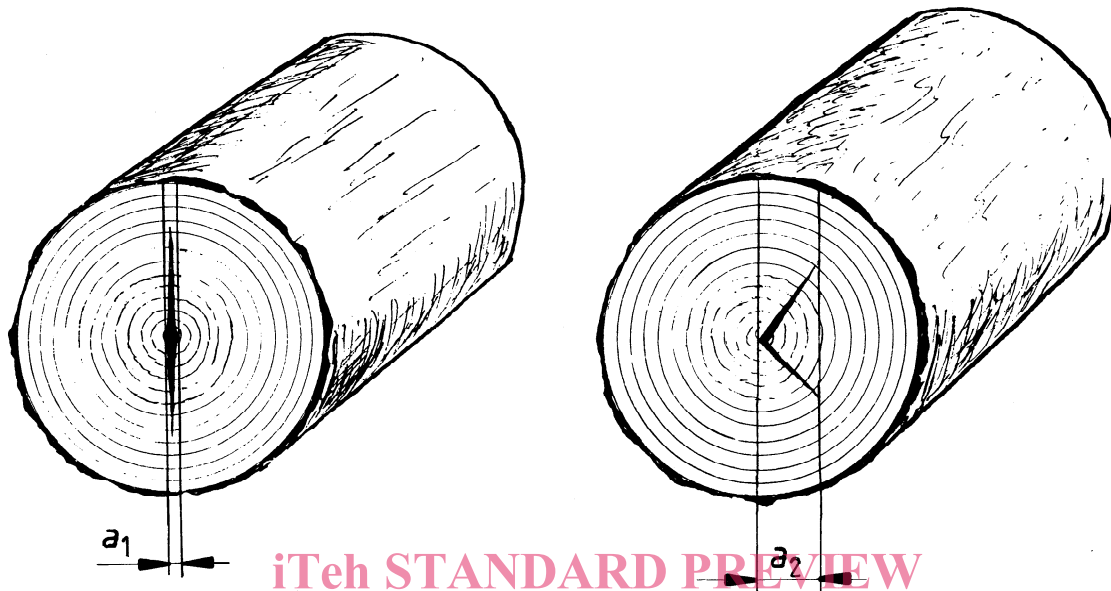

Figure 1 — Measurement of a flush knot



a) Simple heart shake

b) Compound (star) heart shake

ISO 4475:1989
<https://standards.itech.ai/catalog/standards/sist/bc1ec6c0-5939-4fe0-9596-b58a5a2b16e6/iso-4475-1989>

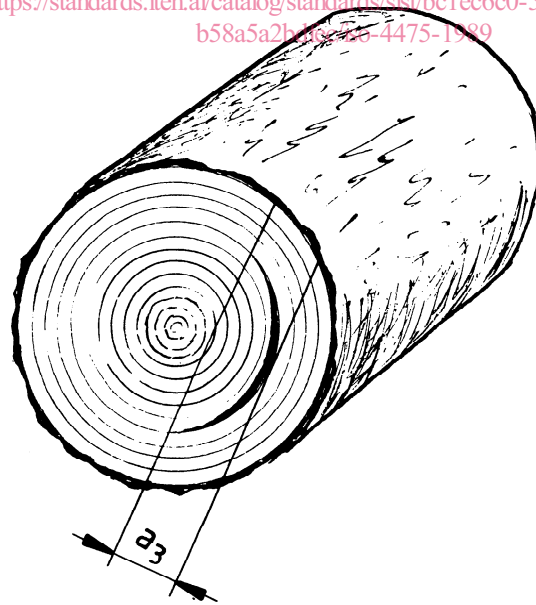

c) Ring shake

Figure 2 — Measurement of end shakes

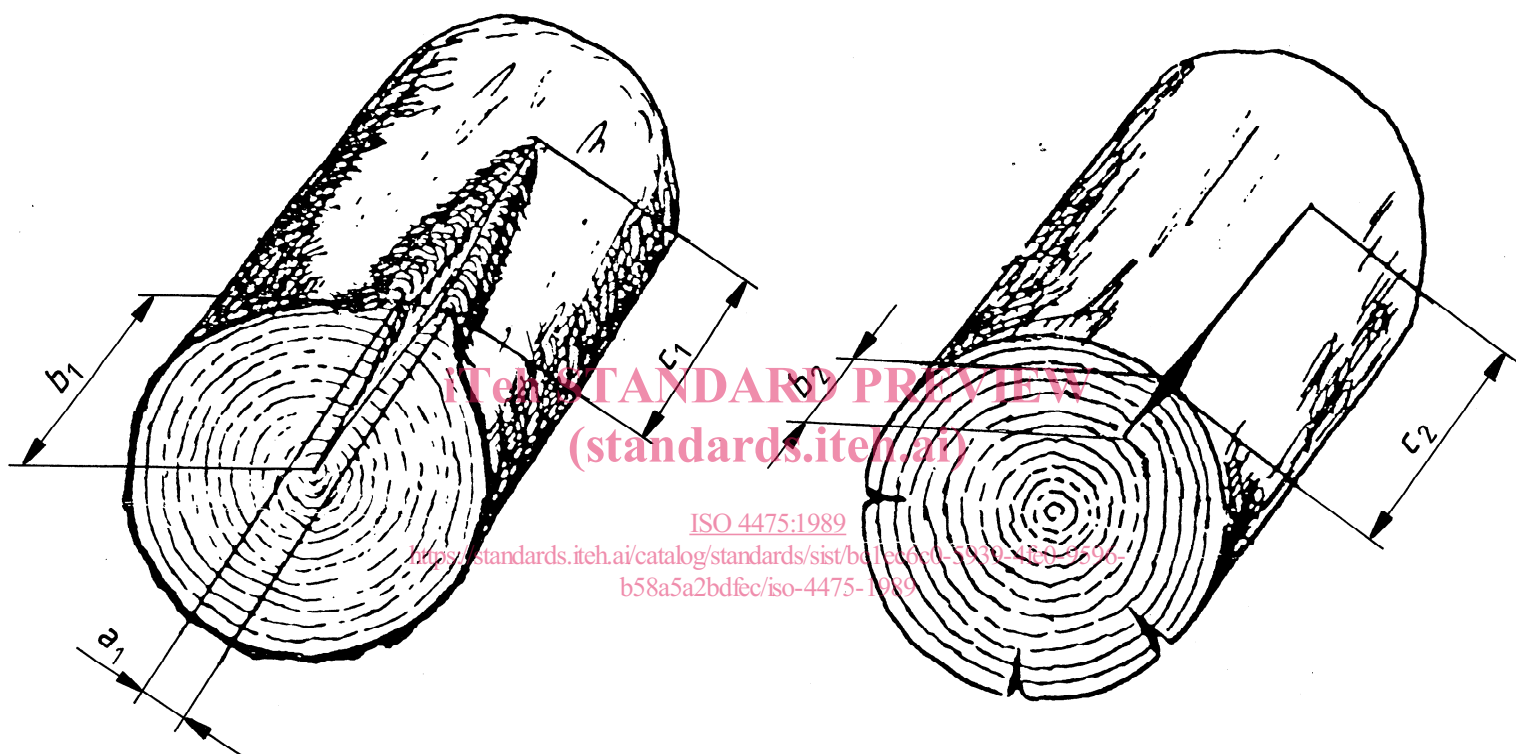

a) Frost crack, shake caused by lightning

b) Drying shake

Figure 3 — Measurement of side shakes

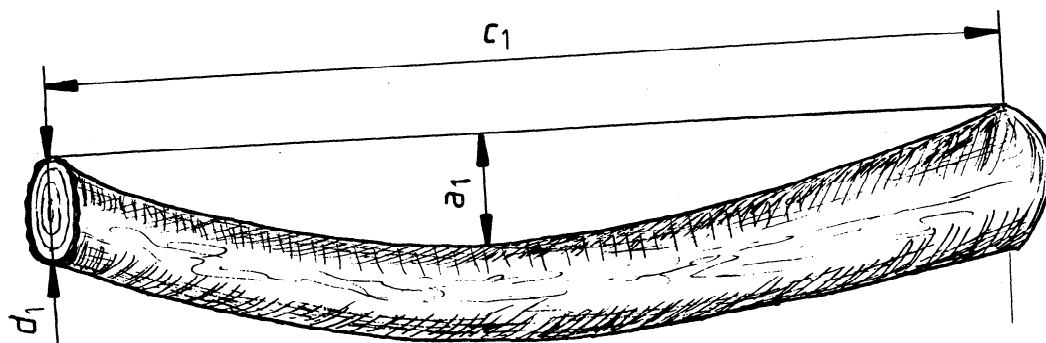

a) Simple curvature ($z_1 = \frac{a_1}{c_1} \times 100$ or $z_1 = \frac{a_1}{d_1}$)

iTeh STANDARD PREVIEW
(standards.iteh.ai)

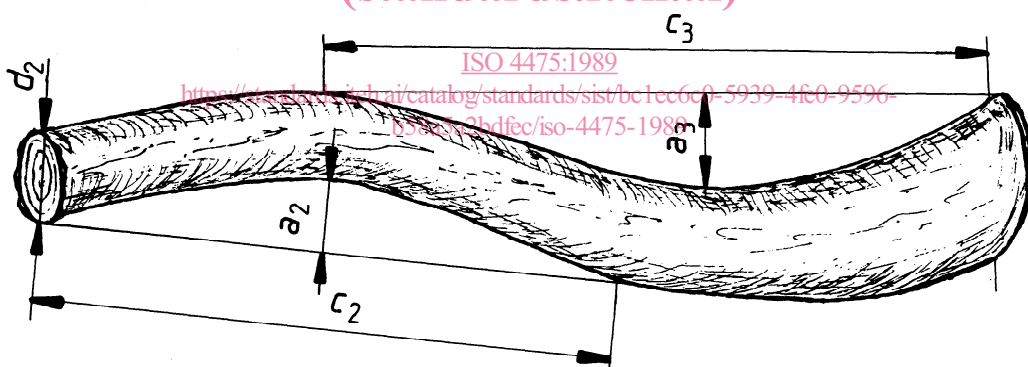

b) Compound curvature ($z_2 = \frac{a_3}{c_3} \times 100$ or $z_2 = \frac{a_3}{d_2}$ where $a_3 > a_2$ and $\frac{a_3}{c_3} > \frac{a_2}{c_2}$)

Figure 4 — Measurement of curvature

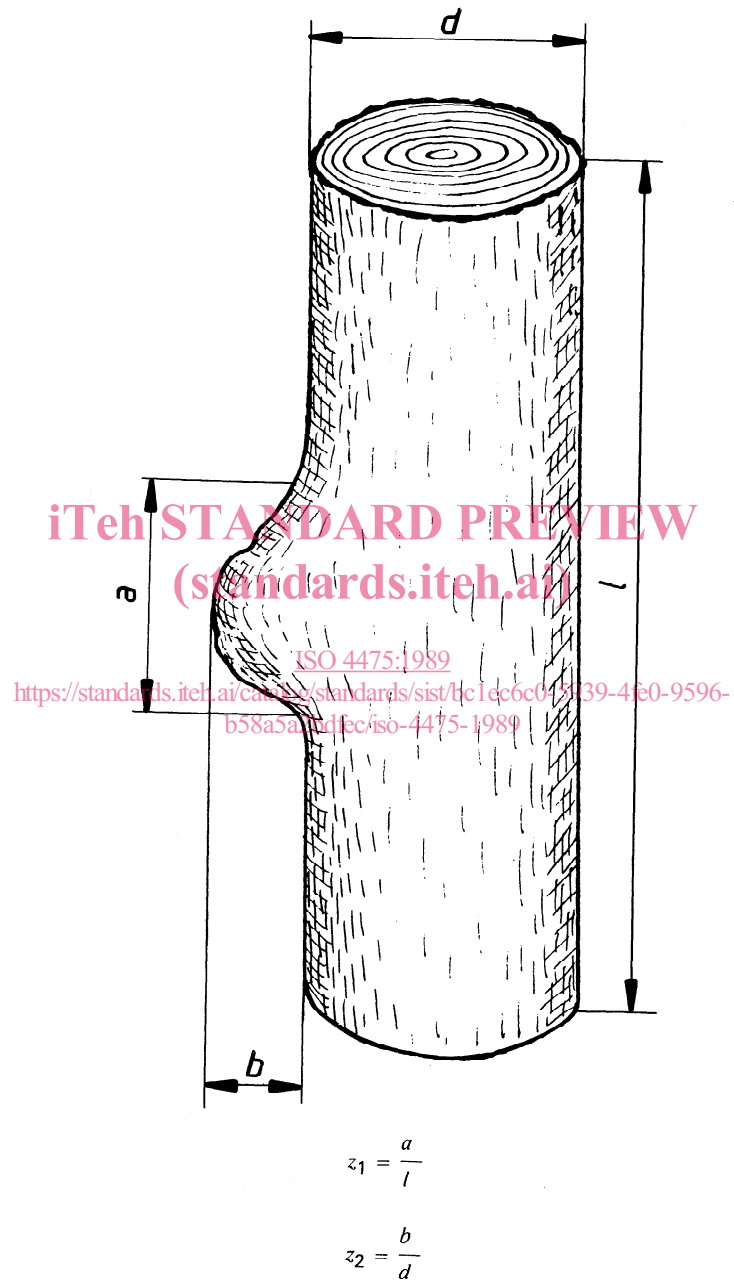

Figure 5 — Measurement of a knob