



Designation: ~~D8210~~—19 D8210 – 19a

Standard Test Method for Automatic Determination of Low-Temperature Viscosity of Automatic Transmission Fluids, Hydraulic Fluids, and Lubricants Using a Rotational Viscometer¹

This standard is issued under the fixed designation D8210; the number immediately following the designation indicates the year of original adoption or, in the case of revision, the year of last revision. A number in parentheses indicates the year of last reapproval. A superscript epsilon (ϵ) indicates an editorial change since the last revision or reapproval.

1. Scope*

1.1 This test method automates the determination of low temperature, low-shear-rate viscosity of driveline and hydraulic fluids, such as automatic transmission fluids, gear oils, hydraulic fluids, and other lubricants. It utilizes a thermoelectrically temperature-controlled sample chamber along with a programmable rotational viscometer. This test method covers a viscosity range of 300 mPa·s to 900 000 mPa·s measured at temperatures from $-40\text{ }^{\circ}\text{C}$ to $-10\text{ }^{\circ}\text{C}$.

1.2 The precision data were determined at $-40\text{ }^{\circ}\text{C}$ and $-26\text{ }^{\circ}\text{C}$ for a viscosity range of 6380 mPa·s to 255 840 mPa·s.

1.3 The values stated in SI units are to be regarded as standard. No other units of measurement are included in this standard except those noted below.

1.3.1 *Exception*—The test method uses the SI unit, milliPascal-second (mPa·s), as the unit of viscosity. (1 cP = 1 mPa·s).

1.4 *This standard does not purport to address all of the safety concerns, if any, associated with its use. It is the responsibility of the user of this standard to establish appropriate safety, health, and environmental practices and determine the applicability of regulatory limitations prior to use.*

1.5 *This international standard was developed in accordance with internationally recognized principles on standardization established in the Decision on Principles for the Development of International Standards, Guides and Recommendations issued by the World Trade Organization Technical Barriers to Trade (TBT) Committee.*

2. Referenced Documents

2.1 ASTM Standards:²

[D341 Practice for Viscosity-Temperature Charts for Liquid Petroleum Products](#)

[D2162 Practice for Basic Calibration of Master Viscometers and Viscosity Oil Standards](#)

[D2983 Test Method for Low-Temperature Viscosity of Automatic Transmission Fluids, Hydraulic Fluids, and Lubricants using a Rotational Viscometer](#)

[D5293 Test Method for Apparent Viscosity of Engine Oils and Base Stocks Between \$-10\text{ }^{\circ}\text{C}\$ and \$-35\text{ }^{\circ}\text{C}\$ Using Cold-Cranking Simulator](#)

[D6708 Practice for Statistical Assessment and Improvement of Expected Agreement Between Two Test Methods that Purport to Measure the Same Property of a Material](#)

[D7962 Practice for Determination of Minimum Immersion Depth and Assessment of Temperature Sensor Measurement Drift](#)

[E644 Test Methods for Testing Industrial Resistance Thermometers](#)

[E2877 Guide for Digital Contact Thermometers](#)

2.2 ISO Standard:³

[ISO/IEC 17025 General requirements for the competence of testing and calibration laboratories](#)

[ISO 17034 General requirement for the competence of reference material producers](#)

¹ This test method is under the jurisdiction of ASTM Committee D02 on Petroleum Products, Liquid Fuels, and Lubricants and is the direct responsibility of Subcommittee D02.07 on Flow Properties.

Current edition approved ~~May 1, 2019~~ July 1, 2019. Published ~~May 2019~~ August 2019. Originally approved in 2018. Last previous edition approved in 2018 as ~~D8210-18~~ D8210 – 19. DOI: ~~10.1520/D8210-19~~ 10.1520/D8210-19A.

² For referenced ASTM standards, visit the ASTM website, www.astm.org, or contact ASTM Customer Service at service@astm.org. For *Annual Book of ASTM Standards* volume information, refer to the standard's Document Summary page on the ASTM website.

³ Available from American National Standards Institute (ANSI), 25 W. 43rd St., 4th Floor, New York, NY 10036, <http://www.ansi.org>.

*A Summary of Changes section appears at the end of this standard

3. Terminology

3.1 Definitions:

3.1.1 *digital contact thermometer (DCT), n*—an electronic device consisting of a digital display and associated temperature sensing probe.

3.1.1.1 Discussion—

This device consists of a temperature sensor connected to a measuring instrument; this instrument measures the temperature-dependent quantity of the sensor, computes the temperature from the measured quantity, and provides a digital output. This digital output goes to a digital display and/or recording device that may be internal or external to the device. These devices are referred to as “digital thermometers.”

3.1.1.2 Discussion—

PET is an acronym for portable electronic thermometer, a subset of digital contact thermometers (DCT).

3.2 Definitions of Terms Specific to This Standard:

3.2.1 *reference viscosity, n*—the viscosity of Newtonian reference fluid whose values were determined by the use of a master viscometer at one or more temperatures.

3.2.2 *test chamber retaining ring, n*—cone-shaped collar that secures the sample tube in the test chamber.

3.2.3 *viscometer retaining ring, n*—the collar that holds the viscometer in position on the viscometer tray.

3.2.4 *viscometer tray, n*—the support platform on which the viscometer is mounted.

4. Summary of Test Method

4.1 A 20 mL sample of the test fluid is heated to 50 °C and held there for 30 min before cooling it to room temperature. This is followed by cooling in a prescribed manner that mimics a sample cooling in an air bath to the test temperature, which follows Newton’s Cooling Law. This thermal conditioning is consistent with that described in the Annex of Test Method [D2983](#). The equation with the constants used are noted in [Annex A1](#). The sample is cooled to test temperature in 1.7 h, then held there for 14 h before the viscosity is measured with a specific insulated spindle at specific series of shear rates (rotational speeds). When the viscosity measurements are complete, the sample chamber is returned to room temperature.

4.2 This test method includes an abbreviated thermal conditioning program, Option B, which is based on the reference in the 1987 and earlier versions of Test Method [D2983](#). This abbreviated program reduces to 4 h the time the sample is held at test temperature before beginning viscosity measurement. Since the time at test temperature is less for this option, the measured viscosity may be lower than the normal length test, Option A, noted in [4.1](#).

4.3 From the beginning of a test until viscosity measurements are complete, the digital viscometer records elapsed time, and sample temperature then during viscosity measurement it records, spindle speed, torque, and viscosity at 10 s intervals for 180 s at each speed. At the end of test, a summary of the viscosity data is displayed by the viscometer. For each spindle speed, the summary contains an average viscosity for the first 160 s and an average of 160 s to 180 s, which is the test result. The test data can be printed or saved to a CSV (comma-separated values) file, which provides a record to both the thermal conditioning and viscosity measurements.

4.4 In recognition of the fact that some samples come directly from the process line at temperatures near the preheat temperature of 50 °C, [Appendix X1](#) lists the program criteria needed for either the full-length test (Option A) without preheat or the abbreviated test (Option B) without preheat.

5. Significance and Use

5.1 The low-temperature, low-shear-rate viscosity of automatic transmission fluids, gear oils, torque and tractor fluids, power steering fluids, and hydraulic oils are of considerable importance to the proper operation of many mechanical devices. Low-temperature viscosity limits of these fluids are often specified to ensure their suitability for use and are cited in many specifications.

5.2 The manual test method, Test Method [D2983](#), was developed to determine whether an automatic transmission fluid (ATF) would meet low-temperature performance criterion originally defined using a particular model viscometer.⁴ The viscosity range covered in the original ATF performance correlation studies was from less than 1000 mPa·s to more than 60 000 mPa·s. The

⁴ Selby, T. W., “Automatic Transmission Fluid Viscosity at Low-Temperatures and Its Effect on Transmission Performance,” *Transactions, Society of Automotive Engineers*, Vol. 68, 1960, pp. 457–465.

success of the ATF correlation and the development of this test method has over time been applied to other fluids and lubricants such as gear oils, hydraulic fluids, and so forth.

5.3 The viscosity determined by this test method using option A was found to be statistically indistinguishable from Test Method **D2983** – 16 measurements based on the ILS data to establish this test method's precision.

5.4 Due to the shorter time at test temperature, results from the abbreviated thermal conditioning (Option B) may differ from results obtained with the 14 h soak at test temperature (Option A). For the samples used in developing this test method, results obtained with the abbreviated procedure (Option B) tended to be less than 14 h soak (Option A). This difference seemed to be larger for products that contained high wax base stock.

6. Apparatus

6.1 *Thermal Conditioning Unit (TCU) and Viscometer Support*⁵—The TCU provides an upper mechanism to hold and position the viscometer described in 6.2 over the sample chamber with its spindle centered on the sample chamber. The lower element of the unit contains a thermo-electric temperature controlled chamber that holds the sample tube. Temperature control is by means of a PID (proportional-integral-derivative) programmable controller capable of at least 0.1 °C control over a range from –45 °C to +90 °C. The time and temperature requirements for each test temperature are in **Annex A1**.

6.2 *Rotational Viscometer*⁶—A digital rotational viscometer with selectable spindle speeds and a maximum torque between 0.0670 mN·m and 0.1800 mN·m and capable of sensing a change in torque of less than 0.3 % of maximum torque. The viscometer shall have an accuracy that is no more than ±1 % of maximum torque. The selection of spindle speeds is at least 0.6 r/min, 1.5 r/min, 3.0 r/min, 6.0 r/min, 12.0 r/min, 30.0 r/min, 60.0 r/min, and 120 r/min. It shall have an integrated RTD sensor with a calibrated range from –45 °C to +90 °C with a resolution of 0.1 °C or less. It shall be capable of automatically initiating the viscosity measurement after a specified elapsed test time, at multiple spindle speeds with each for a specific duration. It shall record elapsed time, temperature, spindle speed, torque, and viscosity throughout a test consistent with data collection parameters in **Annex A2**. A summary of the measured viscosity, torque, and spindle speed will be displayed at test completion with an option to print or save.

NOTE 1—When measuring viscosities below 7000 mPa(s), a viscometer with a maximum torque near the lower limit shown in 6.2 should be selected.

6.3 *Viscometer Spindle*—Insulated viscometer spindle conforming to the following dimensions (**Fig. 1**): A ~ 115 mm, B ~ 3.15 mm, C = 3.15 mm ± 0.03 mm, D = 31.1 mm ± 0.1 mm and made from stainless steel. As shown in **Fig. 1**, the insulated spindle shall have a gap of ~ 4 mm in the upper segment which is covered by a material with poor thermal conduction and pinned to both the upper and lower portions of the upper segment. The gap is to be placed at approximately the mid-point of upper segment. The narrow middle segment shall be ~9.5 mm in length and ~1.8 mm in diameter. In the center of the middle segment will be a narrow band that is centered in the segment and 35.6 mm ± 0.5 mm from the bottom of the spindle.

6.3.1 Periodically (depending on use, but at least every 3 months) inspect spindle for run-out (wobble) when attached to the viscometer. The total run-out of the spindle shall not exceed 1 mm (0 mm ± 0.5 mm).

6.4 *Sample Tube*—A standard laboratory test tube of approximately 25 mm OD and 150 mm in length, preferably without a lip, preferably disposable.

6.5 *Thermometer*—A digital contact thermometer meeting the criteria in **Table 1**.

6.6 *Thermometer Holder*—A sample tube stopper with low thermal conductivity to hold the DCT probe at the correct distance from the top of the sample tube. The stopper consists of two segments. The lower segment is 32 mm ± 2 mm in length and 21 mm ± 2 mm OD. The upper segment is 30 mm ± 2 mm OD and greater than 6 mm in length. The stopper shall include a means of holding the DCT probe at the correct distance from the top of the sample tube. A hole ~3 mm diameter will pass through both segments. See **Fig. 2**.

6.7 *Probe Sheath*—A tube with low thermal conductivity, such as styrene, ~3 mm OD with a 1.8 mm ID that covers the DCT probe below the top of the thermometer holder to 62 mm from tip of DCT probe.

7. Certified Viscosity Reference Standards

7.1 *Sample Temperature Calibration Fluid*—A Newtonian fluid that is free of petroleum waxes and has a viscosity certified by a laboratory that has been shown to meet the requirements of **ISO 17025** by independent assessment, **ISO/IEC 17025** and **ISO 17034** or equivalent by independent assessment for viscosity measurement. The values shall be traceable to a primary standard.

⁵ The sole source of supply known to the committee at this time is Cannon Instrument Company, 2143 High Tech Road, State College, PA 16803, www.cannoninstrument.com. TESC is a registered trademark of Cannon Instrument Company. If you are aware of alternative suppliers, please provide this information to ASTM International Headquarters. Your comments will receive careful consideration at a meeting of the responsible technical committee,¹ which you may attend.

⁶ The sole source of supply known to the committee at this time is AMTEK Brookfield, 11 Commerce Blvd., Middleboro, MA 02346, www.brookfieldengineering.com. Brookfield is a registered trademark of AMETEK Brookfield. If you are aware of alternative suppliers, please provide this information to ASTM International Headquarters. Your comments will receive careful consideration at a meeting of the responsible technical committee,¹ which you may attend.

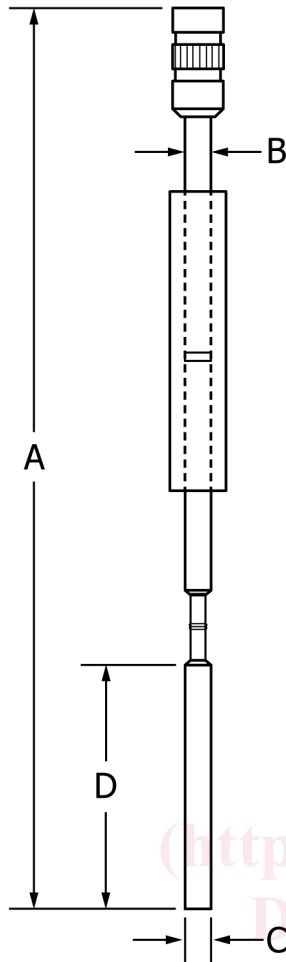

FIG. 1 Insulated Spindle

TABLE 1 Digital Contact Thermometer Criteria

Parameter	Criteria
Nominal Temperature Range ^A	-45 °C to 60 °C
Display resolution	0.1 °C minimum
Accuracy ^B	0.1 °C minimum
Sensor type	PRT
Sensor sheath ^C	1.7 mm OD maximum
Sensor length, ^D maximum	20 mm probe
Immersion depth by D7962 ^E	Less than 40 mm
Measurement Drift ^F	Less than 0.1 °C
Response time ^G	Less than or equal to 4 s
Calibration error	Less than 500 mK (0.5 °C) over the range of intended use.
Temperature calibration data, minimum	Four data points evenly distributed over the calibration range that is consistent with the range of use. The calibration data is to be included in calibration report.
Temperature calibration report	From a calibration laboratory with demonstrated competency in temperature calibration which is traceable to a national calibration laboratory or metrology standards body.

^A A device's minimum and maximum temperature may be different than the values shown provided the calibration requirements are met.

^B Accuracy is the combined accuracy of the DCT unit that is the display and sensor without correction factors. The minimum accuracy criteria match Guide E2877 Class D.

^C Sensor sheath is the tube that holds the sensing element. The value is the outside diameter of the sheath segment containing the sensing element.

^D The physical length of the temperature sensing element. Contact the DCT supplier to determine whether this parameter is met, as it will not be accessible to the user.

^E Minimum probe immersion depth needed for an accurate measurement as determined by Practice D7962 and is to be less than the value in the table. This is a probe characteristic and does not define its positioning in the test method.

^F As determined by Practice D7962 or an equivalent procedure.

^G Response Time—Applies to the digital contact thermometer's (DCT) combined display and sensor system. Conformance with this requirement is to be provided in the manufacturer's or supplier's product documentation. It is defined as the time for a 63.2 % step change in temperature. The step change begins with the DCT probe at an initial temperature of 20 °C ± 5 °C air and the timing begins when it is transferred to water at 77 °C ± 5 °C, which is flowing at 0.9 m/s ± 0.09 m/s past the sensor, as described in Test Method E644 or an equivalent method. The DCT display refresh rate is to be at intervals of every 3 s or less.

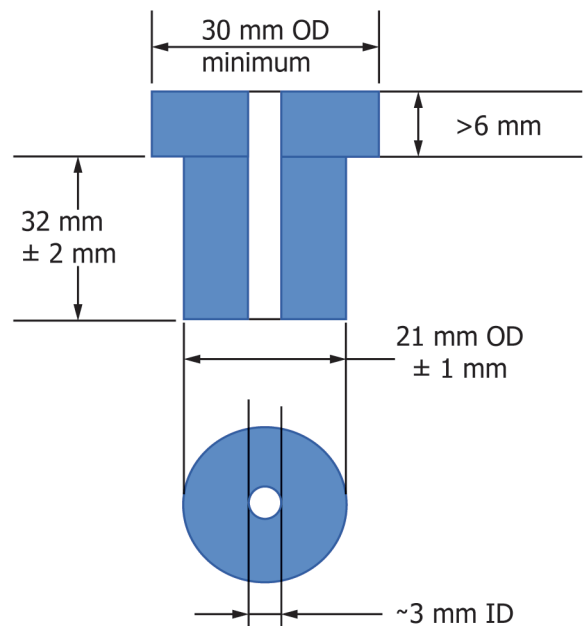

FIG. 2 Sample Tube Stopper

NOTE 2—Typically the calibration constant for the viscometers used in establishing the reference viscosity values is traceable to the primary viscosity standard, water, via the use of Practice [D2162](#).

7.2 Calibration Fluids—See [Table 2](#).

NOTE 3—It is preferable for the calibration fluid’s data to include viscosity values at tenth of a degree increments for 0.5 °C above and below the test temperature at which it is used. This minimizes the need to calculate the temperature from the measured viscosity.

8. Sample Chamber Temperature Calibration

8.1 The following is to determine the difference between sample temperature and the temperature measured by the TCU and viscometer at a test temperature. ~~This difference is referred to as the calibration offset and shall be determined for each test temperature for both sensors. These calibration offsets can be determined either with the use of a DCT (8.7) or by using the viscometer to measure the viscosity (8.8).~~

NOTE 4—~~The sample temperature calibration establishes the temperature difference between the sample and the sensors in the chamber wall and is referred to as a calibration offset. This offset will be different for each test temperature and for each sensor, thus requiring the offsets to be determined for each test temperature wall. By using the calibration offsets for the TCU and viscometer, the displayed or recorded temperature is the temperature of the sample.~~

8.2 Record the current TCU’s calibration temperature offset. (See device’s instruction manual for access details.)

8.3 Record the current viscometer probe offset. (See device’s instruction manual for access details.)

8.4 Place 20 mL ± 0.4 mL of a calibration fluid in a clean 25 mm by 150 mm sample tube.

8.5 Place the sample tube into the TCU chamber.

8.6 To use a DCT to determine offsets follow the instructions in [8.7](#). To determine by measuring sample viscosity, follow the instructions in [8.8](#).

8.7 DCT determination of TCU and viscometer temperature offsets with a DCT meeting [6.5](#) criteria.

8.7.1 Insert DCT probe and sheath through the thermometer holder into sample tube so that the tip is 138 mm ± 2 mm from the rim of the sample tube.

8.7.2 Manually set TCU temperature control to the test temperature for which the offsets are being determined.

8.7.3 Wait 2 h, then record DCT temperature.

8.7.4 If DCT temperature differs from TCU by less than 0.1 °C, then advance to [8.7.7](#).

8.7.5 Adjust the TCU calibration offset as necessary to correct the difference.

8.7.6 Wait 1 h, then record the DCT temperature and repeat [8.7.4](#).

8.7.7 Adjust the viscometer temperature probe offset as necessary to show the sample temperature.

8.7.8 Continue to [8.9](#).

8.8 *Viscometric Determination of Temperature Offsets:*

8.8.1 Without the spindle attached, lower the viscometer tray to its measurement position and initiate the viscometer’s zero compensation function, and when complete, raise the viscometer tray.

8.8.2 Attach the spindle to the viscometer, then lower viscometer tray to the measurement position.

8.8.3 Manually set the TCU temperature control to the test temperature for which the offsets are being determined.

TABLE 2 Calibration Fluids

Test Temperature, °C	Viscosity, mPa·s	Recommended Reference Fluid ^A
-40		CL160
-35		CL200
-30	9000	CL250
-26	to	CL280
-20	14000	CL380
-12		CL600
-10		CL680

TABLE 2 Calibration Fluids

Test Temperature, °C	Viscosity, mPa·s	Recommended Reference Fluid ^A
-40.0		CL160
-35.0		CL200
-30.0	9000	CL250
-26.0	to	CL280
-20.0	14000	CL380
-12.0		CL600
-10.0		CL680

^AThese While the recommended reference fluids are the same as those used in Test Method [D5293](#), other certified viscosity reference standards that meet the criteria in [7.1](#) and [7.2](#) are acceptable.

- 8.8.4 Load the viscometer with the program in [A2.1.1](#).
- 8.8.5 Start the program.
- 8.8.6 When the program is complete, note the viscosity obtained at the highest torque.
- 8.8.7 Determine the sample temperature using the temperature-viscosity data for the standard.

NOTE 5—The sample temperature can be calculated using the reference fluid temperature viscosity data and Practice [D341](#). There are software programs available for this calculation.

- 8.8.8 If the calculated temperature differs by less than 0.1 °C from the calibration fluid's value, then continue to [8.9](#).
- 8.8.9 Calculate a new calibration offset taking into account TCU calibration offset noted in [8.2](#).
- 8.8.10 Enter the new calibration offset into the TCU temperature control following the instructions in the TCU manual.
- 8.8.11 Calculate a new viscometer probe offset, taking into account viscometer probe offset noted in [8.3](#).
- 8.8.12 Enter the new viscometer probe offset following the viscometer's instruction manual.
- 8.8.13 Load the viscometer program in [A2.1.2](#) and start program.
- 8.8.14 When the viscometer measurement program is complete, repeat the steps beginning with [8.8.7](#).
- 8.9 Record the TCU calibration offset and DVT probe offset for future use.
- 8.10 Calibration is complete for this test temperature.

9. Procedure

- 9.1 Place 20 mL ± 0.4 mL of sample in a clean 25 mm by 150 mm sample tube.
- 9.2 Place the sample tube into chamber of the TCU and tighten the retaining ring.
- 9.3 Without the spindle attached, lower the viscometer tray to its measurement position so that the viscometer retaining ring rests on test chamber retaining ring, then initiate the viscometer's zero compensation function. When complete, raise the viscometer tray.
- 9.4 Attach the spindle to the viscometer, then lower viscometer tray until the viscometer retaining ring is resting on the test chamber retaining ring.
- 9.5 *TCU and Viscometer Setup:*
 - 9.5.1 *For an Overnight Thermal Conditioning, Option A:*
 - 9.5.1.1 Verify that the TCU is configured for the intended test temperature. If not, configure the TCU to follow the parameters shown in [A1.1](#) for the appropriate test temperature. Check and adjust the TCU calibration offset if necessary.
 - 9.5.1.2 Configure the viscometer to collect sample data according to the parameters shown in [A2.2.1](#). Check and adjust the viscometer probe offset if necessary.
 - 9.5.2 *For an Abbreviated Thermal Conditioning, Option B:*
 - 9.5.2.1 Verify that the TCU is configured for the intended test temperature. If not, configure the TCU to follow the parameters shown in [A1.2](#) for the appropriate test temperature. Check and adjust the TCU calibration offset if necessary.
 - 9.5.2.2 Configure the viscometer to collect sample data according to the parameters shown in [A2.2.2](#). Check and adjust the viscometer probe offset if necessary.
- 9.6 Start the TCU thermal conditioning program and the viscometer.

NOTE 6—Option A thermal conditioning and viscosity measurement will be complete in 17 h and 12 min. Option B thermal conditioning and viscosity measurement will be complete in 6 h and 54 min.

- 9.7 Record the viscosity, torque, spindle speed, and temperature for the average recorded during 160 s to 180 s spindle speed measurement where the torque is less than 80 % and greater 20 %. If there are two spindle speeds meeting the criteria, record the values at the highest spindle speed.
 - 9.7.1 Optionally save the data to a file. Include in the file name: sample ID, instrument ID, date, whether Standard or Abbreviated conditioning, and other identifiers as appropriate.

10. Report

- 10.1 The report shall include the following:
 - 10.1.1 Viscosity,
 - 10.1.2 Spindle speed,
 - 10.1.3 Torque,
 - 10.1.4 Test temperature, and
 - 10.1.5 Thermal conditioning option.

11. Precision and Bias

11.1 *Precision*—The precision for option A of this test method was determined by statistical examination of the interlaboratory test results at –40 °C and –26 °C, over a viscosity range of 6380 mPa·s to 255 840 mPa·s where the viscosity is the average measured value between an elapsed measurement time of 160 s and 180 s.