

INTERNATIONAL STANDARD



Conduit systems for cable management –
Part 23: Particular requirements – Flexible conduit systems

Standards
(<https://standards.iteh.ai>)
Document Preview

[IEC 61386-23:2021](https://standards.iteh.ai/catalog/standards/iec/7d551622-adb5-4960-9a0f-b3e29f848f6b/iec-61386-23-2021)

<https://standards.iteh.ai/catalog/standards/iec/7d551622-adb5-4960-9a0f-b3e29f848f6b/iec-61386-23-2021>



THIS PUBLICATION IS COPYRIGHT PROTECTED
Copyright © 2021 IEC, Geneva, Switzerland

All rights reserved. Unless otherwise specified, no part of this publication may be reproduced or utilized in any form or by any means, electronic or mechanical, including photocopying and microfilm, without permission in writing from either IEC or IEC's member National Committee in the country of the requester. If you have any questions about IEC copyright or have an enquiry about obtaining additional rights to this publication, please contact the address below or your local IEC member National Committee for further information.

IEC Central Office
3, rue de Varembe
CH-1211 Geneva 20
Switzerland

Tel.: +41 22 919 02 11
info@iec.ch
www.iec.ch

About the IEC

The International Electrotechnical Commission (IEC) is the leading global organization that prepares and publishes International Standards for all electrical, electronic and related technologies.

About IEC publications

The technical content of IEC publications is kept under constant review by the IEC. Please make sure that you have the latest edition, a corrigendum or an amendment might have been published.

IEC publications search - webstore.iec.ch/advsearchform

The advanced search enables to find IEC publications by a variety of criteria (reference number, text, technical committee, ...). It also gives information on projects, replaced and withdrawn publications.

IEC Just Published - webstore.iec.ch/justpublished

Stay up to date on all new IEC publications. Just Published details all new publications released. Available online and once a month by email.

IEC Customer Service Centre - webstore.iec.ch/csc

If you wish to give us your feedback on this publication or need further assistance, please contact the Customer Service Centre: sales@iec.ch.

IEC online collection - oc.iec.ch

Discover our powerful search engine and read freely all the publications previews. With a subscription you will always have access to up to date content tailored to your needs.

Electropedia - www.electropedia.org

The world's leading online dictionary on electrotechnology, containing more than 22 000 terminological entries in English and French, with equivalent terms in 18 additional languages. Also known as the International Electrotechnical Vocabulary (IEV) online.

International Standards
Document Preview
standards.iteh.ai

[IEC 61386-23:2021](http://www.iec.ch)

<https://standards.iteh.ai/catalog/standards/iec/7d551622-adb5-4960-9a0f-b3e29f848f6b/iec-61386-23-2021>



IEC 61386-23

Edition 2.0 2021-04
REDLINE VERSION

INTERNATIONAL STANDARD



**Conduit systems for cable management –
Part 23: Particular requirements – Flexible conduit systems**

Document Preview

[IEC 61386-23:2021](https://standards.iteh.ai/7d551622-adb5-4960-9a0f-b3e29f848f6b/iec-61386-23-2021)

<https://standards.iteh.ai/catalog/standards/iec/7d551622-adb5-4960-9a0f-b3e29f848f6b/iec-61386-23-2021>

INTERNATIONAL
ELECTROTECHNICAL
COMMISSION

ICS 29.120.10

ISBN 978-2-8322-9709-4

Warning! Make sure that you obtained this publication from an authorized distributor.

CONTENTS

FOREWORD	3
1 Scope	6
2 Normative references	6
3 Terms and definitions	6
4 General requirements	6
5 General conditions for tests	6
6 Classification	6
7 Marking and documentation	7
8 Dimensions	7
9 Construction	7
10 Mechanical properties	7
11 Electrical properties	9
12 Thermal properties	9
13 Fire-effects hazard	10
14 External influences	10
15 Electromagnetic compatibility	10
Annex A (normative) Classification coding for conduit systems	15
Annex B (normative) Determination of material thickness	15
Annex C (normative) Additional test requirements for conduit systems already complying with IEC 61386-1:2008	15
Annex AA (informative) Calculation for minimum and maximum rate of increase of force for 10.2.4	16
Figure 101 – Flexing test apparatus	11
Figure 102 – Gauge for checking the minimum inside diameter of the conduit system after impact and resistance to heat tests	12
Figure 103 – Assembly of conduit and terminating conduit fitting for bonding test	13
Figure AA.1 – Graph showing force against time for 750 N force	16
Table AA.1 – Minimum and maximum rate of increase of force for 10.2.4	17

<https://standards.iteh.ai/catalog/standards/iec/7d551622-adb5-4960-9a0f-b3e29f848f6b/iec-61386-23-2021>

<https://standards.iteh.ai/catalog/standards/iec/7d551622-adb5-4960-9a0f-b3e29f848f6b/iec-61386-23-2021>

INTERNATIONAL ELECTROTECHNICAL COMMISSION

CONDUIT SYSTEMS FOR CABLE MANAGEMENT –**Part 23: Particular requirements – Flexible conduit systems****FOREWORD**

- 1) The International Electrotechnical Commission (IEC) is a worldwide organization for standardization comprising all national electrotechnical committees (IEC National Committees). The object of IEC is to promote international co-operation on all questions concerning standardization in the electrical and electronic fields. To this end and in addition to other activities, IEC publishes International Standards, Technical Specifications, Technical Reports, Publicly Available Specifications (PAS) and Guides (hereafter referred to as “IEC Publication(s)”). Their preparation is entrusted to technical committees; any IEC National Committee interested in the subject dealt with may participate in this preparatory work. International, governmental and non-governmental organizations liaising with the IEC also participate in this preparation. IEC collaborates closely with the International Organization for Standardization (ISO) in accordance with conditions determined by agreement between the two organizations.
- 2) The formal decisions or agreements of IEC on technical matters express, as nearly as possible, an international consensus of opinion on the relevant subjects since each technical committee has representation from all interested IEC National Committees.
- 3) IEC Publications have the form of recommendations for international use and are accepted by IEC National Committees in that sense. While all reasonable efforts are made to ensure that the technical content of IEC Publications is accurate, IEC cannot be held responsible for the way in which they are used or for any misinterpretation by any end user.
- 4) In order to promote international uniformity, IEC National Committees undertake to apply IEC Publications transparently to the maximum extent possible in their national and regional publications. Any divergence between any IEC Publication and the corresponding national or regional publication shall be clearly indicated in the latter.
- 5) IEC itself does not provide any attestation of conformity. Independent certification bodies provide conformity assessment services and, in some areas, access to IEC marks of conformity. IEC is not responsible for any services carried out by independent certification bodies.
- 6) All users should ensure that they have the latest edition of this publication.
- 7) No liability shall attach to IEC or its directors, employees, servants or agents including individual experts and members of its technical committees and IEC National Committees for any personal injury, property damage or other damage of any nature whatsoever, whether direct or indirect, or for costs (including legal fees) and expenses arising out of the publication, use of, or reliance upon, this IEC Publication or any other IEC Publications.
- 8) Attention is drawn to the Normative references cited in this publication. Use of the referenced publications is indispensable for the correct application of this publication.
- 9) Attention is drawn to the possibility that some of the elements of this IEC Publication may be the subject of patent rights. IEC shall not be held responsible for identifying any or all such patent rights.

This redline version of the official IEC Standard allows the user to identify the changes made to the previous edition IEC 61386-23:2002. A vertical bar appears in the margin wherever a change has been made. Additions are in green text, deletions are in strikethrough red text.

International Standard IEC 61386-23 has been prepared by subcommittee 23A: Cable management systems, of IEC technical committee 23: Electrical accessories:

This second edition cancels and replaces the first edition published in 2002. This edition constitutes a technical revision.

This edition includes the following significant technical changes with respect to the previous edition:

- a) Annex AA has been added to provide guidance on the application of a constantly increasing force.

The text of this International Standard is based on the following documents:

FDIS	Report on voting
23A/952/FDIS	23A/957/RVD

Full information on the voting for the approval of this International Standard can be found in the report on voting indicated in the above table.

This document has been drafted in accordance with the ISO/IEC Directives, Part 2.

A list of all the parts in the IEC 61386 series, published under the general title *Conduit systems for cable management*, can be found on the IEC website.

This document is to be used in conjunction with IEC 61386-1:2008 and IEC 61386-1:2008/AMD1:2017.

This document supplements or modifies the corresponding clauses of IEC 61386-1:2008 and IEC 61386-1:2008/AMD1:2017. Where a particular clause or subclause of IEC 61386-1:2008 and IEC 61386-1:2008/AMD1:2017 is not mentioned in this document, that clause or subclause applies as far as is reasonable. Where this document states "addition", "modification" or "replacement", the relevant text of IEC 61386-1:2008 and IEC 61386-1:2008/AMD1:2017 is to be adapted accordingly.

Subclauses, tables and figures which are in addition to those in IEC 61386-1:2008 and IEC 61386-1:2008/AMD1:2017 are numbered starting with 101. Annexes which are additional to those in IEC 61386-1:2008 and IEC 61386-1:2008/AMD1:2017 are lettered AA, BB, etc.

In this document, the following print types are used:

- Requirements proper: in roman type.
- *Test specifications: in italic type.*
- Explanatory matter: in smaller roman type.

The committee has decided that the contents of this document will remain unchanged until the stability date indicated on the IEC website under "<http://webstore.iec.ch>" in the data related to the specific document. At this date, the document will be

- reconfirmed,
- withdrawn,
- replaced by a revised edition, or
- amended.

IMPORTANT – The 'colour inside' logo on the cover page of this publication indicates that it contains colours which are considered to be useful for the correct understanding of its contents. Users should therefore print this document using a colour printer.

iTeh Standards
(<https://standards.iteh.ai>)
Document Preview

[IEC 61386-23:2021](#)

<https://standards.iteh.ai/catalog/standards/iec/7d551622-adb5-4960-9a0f-b3e29f848f6b/iec-61386-23-2021>

CONDUIT SYSTEMS FOR CABLE MANAGEMENT –

Part 23: Particular requirements – Flexible conduit systems

1 Scope

~~This clause of part 1 is applicable, except as follows:~~

Clause 1 of IEC 61386-1:2008 is applicable, except as follows:

Addition:

This part of IEC 61386 specifies the requirements for flexible conduit systems.

2 Normative references

~~This clause of part 1 is applicable.~~

Clause 2 of IEC 61386-1:2008 and of IEC 61386-1:2008/AMD1:2017 are applicable, except as follows:

Addition:

IEC 61386-1:2008, *Conduit systems for cable management – Part 1: General requirements*
IEC 61386-1:2008/AMD1:2017

3 Terms and definitions

~~This clause of part 1 is applicable.~~

Clause 3 of IEC 61386-1:2008 and of IEC 61386-1:2008/AMD1:2017 are applicable.

4 General requirements

~~This clause of part 1 is applicable.~~

Clause 4 of IEC 61386-1:2008 is applicable.

5 General conditions for tests

~~This clause of part 1 is applicable.~~

Clause 5 of IEC 61386-1:2008 and of IEC 61386-1:2008/AMD1:2017 are applicable.

6 Classification

~~This clause of part 1 is applicable, except as follows:~~

Clause 6 of IEC 61386-1:2008 is applicable, except as follows:

~~Subclauses~~ Classifications 6.1.3, 1; 6.1.3, 2 and 6.1.3, 3 are not applicable.

NOTE Flexible conduit systems according to 6.1.1, 1; 6.1.1, 2; 6.1.2, 1; 6.1.2, 2 and classification ~~4X~~ 1 from 6.2.1, Table 1 are not allowed in France.

7 Marking and documentation

~~This clause of part 1 is applicable, except as follows:~~

Clause 7 of IEC 61386-1:2008 and of IEC 61386-1:2008/AMD1:2017 are applicable, except as follows:

Addition:

7.1.101 The conduit shall be marked in accordance with 7.1 along its entire length at regular intervals of preferably 1 m but not longer than 3 m. Where this is technically impractical, the mark shall be on a label attached to the product at each end, or on the packaging.

Compliance is checked by inspection.

7.1.102 The manufacturer shall document or ~~add to~~ include in the packaging ~~for the system~~, the minimum inside diameter, the minimum bend radius and the classification in accordance with Clause 6 for the conduit system.

Compliance is checked by inspection of the documentation.

8 Dimensions

Replacement:

<https://standards.iteh.ai/catalog/standards/iec/7d551622-adb5-4960-9a0f-b3e29f848f6b/iec-61386-23-2021>

8.1 Threads shall comply with IEC 60423.

Compliance is checked by means of the gauges specified in IEC 60423.

8.2 The minimum inside diameter of the conduit system shall be as declared by the manufacturer.

Compliance is checked by measurement.

9 Construction

~~This clause of part 1 is applicable.~~

Clause 9 of IEC 61386-1:2008 is applicable.

10 Mechanical properties

~~This clause of part 1 is applicable, except as follows:~~

~~10.1 Mechanical strength~~

~~10.1.1 Addition:~~

~~NOTE—Very light flexible conduits should not be considered as providing adequate mechanical protection and should not be used within the construction of buildings.~~

Clause 10 of IEC 61386-1:2008 and of IEC 61386-1:2008/AMD1:2017 are applicable, except as follows:

10.2 Compression test

Subclause 10.2 is applicable with the following addition:

10.2.4 Add the following note at the end of Subclause 10.2.4:

NOTE In order to achieve a uniformly increasing compression force, the force indicated in Table 4 is divided by time; this value is the required rate per second to fulfil the requirement.

Example: For a test force of 750 N an increase of the test force of 25 N/s is required (750 divided by 30 equals 25). Informative Annex AA gives detailed calculations including tolerances for time and force.

10.4 Bending test

~~This subclause of part 1 is not applicable.~~

Subclause 10.4 of IEC 61386-1:2008 is not applicable.

10.5 Flexing test

Addition:

10.5.101 An assembly consisting of a conduit with a terminating conduit fitting, assembled in accordance with the manufacturer's instructions, shall be subjected to a flexing test by means of the apparatus shown in Figure 101.

10.5.102 The test shall be made on six samples of conduit of an appropriate length. Three of the samples shall be tested at the minimum declared temperature for transport, application and installation ~~temperature~~ as given in Table 1 with a tolerance of ± 2 °C. The other three samples shall be tested at the maximum declared application and installation temperature as given in Table 2 with a tolerance of ± 2 °C.

A manufacturer may declare that a flexible conduit is suitable for transport and installation according to Table 1 but may only be suitable for flexing at ambient temperature as a minimum. In this case the test shall be carried out at (20 ± 2) °C and the third digit of the classification code shall be X. The manufacturer shall clearly declare in its literature both the minimum transport and installation temperature in accordance with Table 1, the minimum application temperature which is ambient and the maximum installation and application temperature in accordance with Table 2.

10.5.103 The sample shall be fixed to the oscillating member by means of the terminating conduit fitting as shown in Figure 101, so that when the conduit is at the middle of its travel, the axis of the conduit is vertical and passes through the axis of the oscillation. The apparatus with the sample shall be conditioned for 2 h or until the sample has attained the declared temperature, whichever period is the longer.

10.5.104 The oscillating member shall be moved backwards and forwards through a total angle of $(180 \pm 5)^\circ$ divided equally about the vertical axis. The assembly shall be subjected to 5 000 flexings at a rate of (40 ± 5) flexings per minute. A flexing constitutes, starting from the vertical position, one continuous cycle of movement of essentially sinusoidal forms.

10.5.105 After the test, the sample shall show no ~~sign of disintegration, nor shall there be any~~ cracks visible to normal or corrected vision without magnification and it shall be possible to

pass the appropriate gauge, as shown in Figure 102, through the sample under its own weight and without any initial speed.

10.6 Collapse test

~~This subclause of part 1 is not applicable.~~

Subclause 10.6 of IEC 61386-1:2008 is not applicable.

10.7 Tensile ~~strength~~ test

~~This subclause of part 1 is applicable, except as follows:~~

Subclause 10.7 of IEC 61386-1:2008 is applicable, except as follows:

10.7.3 Replacement:

For conduit systems where tensile strength is not declared, the tensile strength of the joint shall comply with classification 1 in Table 6.

11 Electrical properties

~~This clause of part 1 is applicable, except as follows:~~

Clause 11 of IEC 61386-1:2008 and of IEC 61386-1:2008/AMD1:2017 are applicable, except as follows:

11.2 Bonding test

Replacement:

A sample of a conduit and terminating conduit fitting shall be assembled in accordance with the manufacturer's instructions and mounted as shown in Figure 103. A current of 25 A, having a frequency of 50 Hz to 60 Hz, derived from an AC source having a no-load voltage not exceeding 12 V, shall be passed through the assembly for (60^{+5}_0) s. Then the voltage drop shall be measured between the points shown in Figure 103 and the resistance calculated from the current and this voltage drop.

The resistance shall not exceed 0,05 Ω .

~~Where special devices are required for the coupling of conduit and conduit fittings, they shall be sufficient to remove the protective coating from the conduit, or the protective finish shall be removed in accordance with the manufacturer's instructions.~~

12 Thermal properties

~~This clause of part 1 is applicable, except as follows:~~

Clause 12 of IEC 61386-1:2008 is applicable, except as follows:

~~12.2.4~~ 12.3 Replacement:

The load is then removed and immediately after its removal it shall be possible to pass the appropriate gauge, in accordance with Figure 102, through the conduit under its own weight and without any initial speed, with the sample in the vertical position.

13 Fire ~~effects~~ hazard

~~This clause of part 1 is applicable.~~

Clause 13 of IEC 61386-1:2008 and of IEC 61386-1:2008/AMD1:2017 are applicable.

14 External influences

~~This clause of part 1 is applicable.~~

Clause 14 of IEC 61386-1:2008 and of IEC 61386-1:2008/AMD1:2017 are applicable.

15 Electromagnetic compatibility

~~This clause of part 1 is applicable.~~

Clause 15 of IEC 61386-1:2008 and of IEC 61386-1:2008/AMD1:2017 are applicable.

iTeh Standards
(<https://standards.iteh.ai>)
Document Preview

[IEC 61386-23:2021](#)

<https://standards.iteh.ai/catalog/standards/iec/7d551622-adb5-4960-9a0f-b3e29f848f6b/iec-61386-23-2021>

Addition:

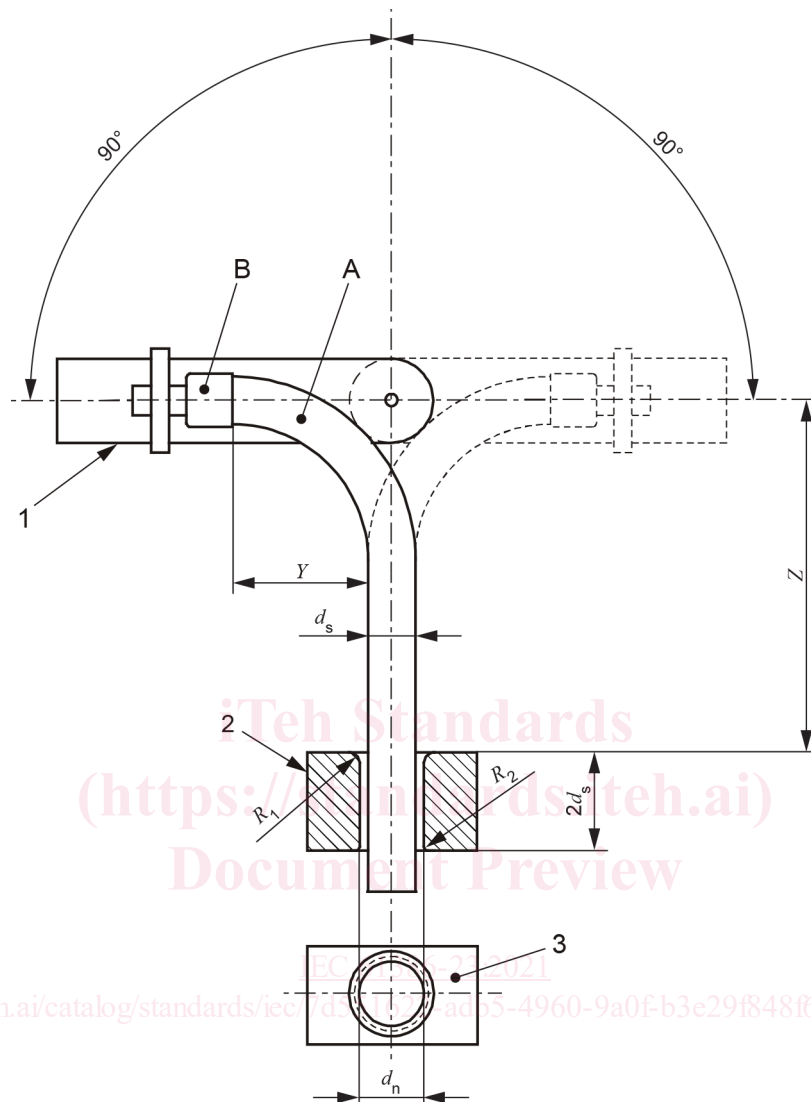

IEC

Key

- A Conduit
- B Terminating fitting
- d_s Outside diameter of conduit (A)
- d_n Inside diameter of support block: $1,1 \times d_s$
- R_1 Radius of support block: $0,5 \times d_s$
- R_2 Radius of support block: $0,25 \times d_s$
- Y Minimum bend radius, declared by the manufacturer
- Z $1,5 \times Y$
- 1 Oscillating member
- 2 Guide support block
- 3 Plan view of guide support block

NOTE This drawing is not intended to govern design except as regards the dimensions shown.

Figure 101 – Flexing test apparatus

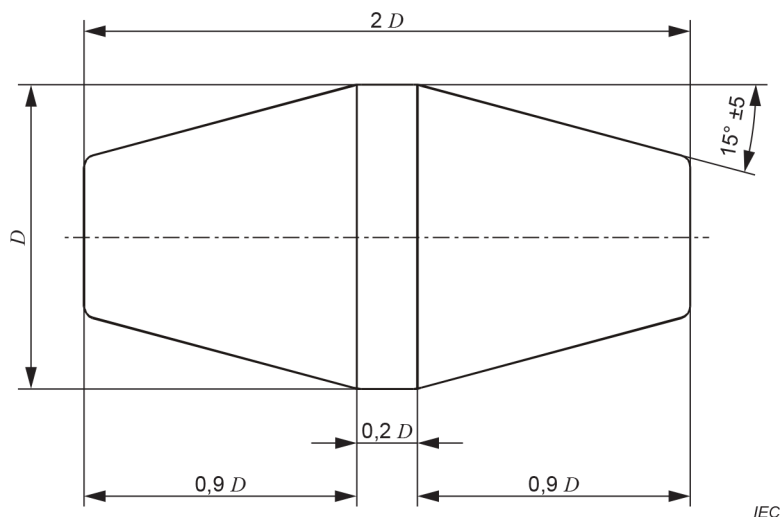

D	80 % of the manufacturer's declared minimum inside diameter of the conduit system
Material	Steel, hardened and polished, edges slightly rounded
Manufacturing tolerance	$+0,05$ 0 mm
Tolerance and axial dimension	$\pm 0,2$ mm
Admissible wear	0,01 mm

NOTE This drawing is not intended to govern design except as regards the dimensions shown.

Figure 102 – Gauge for checking the minimum inside diameter of the conduit system after impact and resistance to heat tests

[IEC 61386-23:2021](https://standards.iteh.ai/standards/iec/7d551622-adb5-4960-9a0f-b3e29f848f6b/iec-61386-23-2021)

<https://standards.iteh.ai/catalog/standards/iec/7d551622-adb5-4960-9a0f-b3e29f848f6b/iec-61386-23-2021>