



# Standard Specification for Contact-Molded Glass-Fiber-Reinforced Thermoset Resin Corrosion-Resistant Tanks<sup>1</sup>

This standard is issued under the fixed designation D4097; the number immediately following the designation indicates the year of original adoption or, in the case of revision, the year of last revision. A number in parentheses indicates the year of last reapproval. A superscript epsilon ( $\epsilon$ ) indicates an editorial change since the last revision or reapproval.

*This standard has been approved for use by agencies of the U.S. Department of Defense.*

## 1. Scope

1.1 This specification covers cylindrical tanks fabricated by contact molding for above-ground vertical installation, to contain aggressive chemicals at atmospheric pressure, and made of a commercial-grade polyester or vinyl ester, resin. Included are requirements for materials, properties, design, construction, dimensions, tolerances, workmanship, and appearance.

1.2 This specification does not cover the design of vessels intended for pressure above atmospheric or under vacuum conditions, except as classified herein, or vessels intended for use with liquids heated above their flash points.

1.3 The values stated in inch-pound units are to be regarded as standard. The values given in parentheses are provided for information purposes only.

1.4 Special design consideration shall be given to tanks subject to environmental and/or mechanical forces such as seismic, wind, ice, agitation, or fluid dynamic forces, to operational service temperatures greater than 180°F (82°C) and to tanks with unsupported bottoms.

1.5 The following safety hazards caveat pertains only to the test method portion, Section 11, of this specification: *This standard does not purport to address all of the safety concerns, if any, associated with its use. It is the responsibility of the user of this standard to establish appropriate safety, health, and environmental practices and determine the applicability of regulatory limitations prior to use.*

NOTE 1—There is no known ISO equivalent to this standard.

1.6 *This international standard was developed in accordance with internationally recognized principles on standardization established in the Decision on Principles for the Development of International Standards, Guides and Recommendations issued by the World Trade Organization Technical Barriers to Trade (TBT) Committee.*

<https://standards.iteh.ai/catalog/standards/sist/5ac998a9-d1ed-471e-be0f-fe55326d6f89/astm-d4097-19>

## 2. Referenced Documents

### 2.1 ASTM Standards:<sup>2</sup>

**C581 Practice for Determining Chemical Resistance of Thermosetting Resins Used in Glass-Fiber-Reinforced Structures Intended for Liquid Service**

**C582 Specification for Contact-Molded Reinforced Thermosetting Plastic (RTP) Laminates for Corrosion-Resistant Equipment**

**D618 Practice for Conditioning Plastics for Testing**

**D638 Test Method for Tensile Properties of Plastics**

**D790 Test Methods for Flexural Properties of Unreinforced and Reinforced Plastics and Electrical Insulating Materials**

**D883 Terminology Relating to Plastics**

**D2150 Specification for Woven Roving Glass Fabric for Polyester-Glass Laminates (Withdrawn 1987)<sup>3</sup>**

**D2583 Test Method for Indentation Hardness of Rigid Plastics by Means of a Barcol Impressor**

**D2584 Test Method for Ignition Loss of Cured Reinforced Resins**

**D2996 Specification for Filament-Wound “Fiberglass” (Glass-Fiber-Reinforced Thermosetting-Resin) Pipe**

<sup>1</sup> This specification is under the jurisdiction of ASTM Committee D20 on Plastics and is the direct responsibility of Subcommittee D20.23 on Reinforced Plastic Piping Systems and Chemical Equipment.

Current edition approved Aug. 1, 2018. Published August 2018. Originally approved in 1982. Last previous edition approved in 2018 as D4097-01D4097-18 (2019). DOI: 10.1520/D4097-18.10.1520/D4097-19.

<sup>2</sup> For referenced ASTM standards, visit the ASTM website, [www.astm.org](http://www.astm.org), or contact ASTM Customer Service at [service@astm.org](mailto:service@astm.org). For *Annual Book of ASTM Standards* volume information, refer to the standard's Document Summary page on the ASTM website.

<sup>3</sup> The last approved version of this historical standard is referenced on [www.astm.org](http://www.astm.org).

D2997 Specification for Centrifugally Cast “Fiberglass” (Glass-Fiber-Reinforced Thermosetting-Resin) Pipe  
D3892 Practice for Packaging/Packing of Plastics  
D4024 Specification for Machine Made “Fiberglass” (Glass-Fiber-Reinforced Thermosetting Resin) Flanges  
D5421 Specification for Contact Molded “Fiberglass” (Glass-Fiber-Reinforced Thermosetting Resin) Flanges  
F412 Terminology Relating to Plastic Piping Systems

## 2.2 ANSI Standards:

B 16.1 Cast Iron Pipe Flanges and Flanged Fittings, Class 25, 125, 250, and 800<sup>4</sup>  
B 16.5 Steel Pipe Flanges, Flanged Valves and Fittings<sup>4</sup>

## 3. Terminology

3.1 *Definitions*—Definitions are in accordance with Terminologies D883 and F412, unless otherwise indicated.

3.2 *Definitions of Terms Specific to This Standard:*

3.2.1 *contact molding*—includes the “hand lay-up” or a combination of the “hand lay-up” and the “spray-up” manufacturing processes.

## 4. Classification

4.1 Tanks meeting this specification are classified according to type. It is the responsibility of the purchaser to specify the requirement for Type II tanks, the operating pressure or vacuum levels, and the safety factor required for external pressure. Absence of a designation of type required shall imply that Type I is adequate.

4.1.1 *Type I*—Atmospheric pressure tanks vented directly to the atmosphere, designed for pressure no greater or lower than atmospheric.

4.1.2 *Type II*—Atmospheric pressure tanks vented directly into a fume conservation system, and designed to withstand, the specified positive and negative pressure not to exceed 14 in. of water (355.6 mm) when all tie-down lugs are properly secured, in accordance with the fabricator’s recommendations for flat-bottom tanks.

4.2 Tanks meeting this specification are classified according to type as follows:

4.2.1 *Grade 1*—Tanks manufactured with a single generic type of thermoset resin throughout.

4.2.2 *Grade 2*—Tanks manufactured with different generic types of thermoset resin in the barrier and the structural portion.

NOTE 2—The external corrosive environment due to spillage or corrosive vapors should be considered when specifying Grade 2 tanks (see 7.1.3.3).

## 5. Materials and Manufacture

5.1 *Resin*—The resin used shall be a commercial grade, corrosion-resistant thermoset that has either been evaluated in a laminate by test in accordance with 11.3, or that has been determined by previous documented service to be acceptable for the service conditions. Where service conditions have not been evaluated, a suitable resin may also be selected by agreement between fabricator and purchaser.

5.1.1 The resin shall contain no pigment, dyes, colorants, or filler, except as follows:

5.1.1.1 A thixotropic agent that does not interfere with visual inspection of laminate quality, or with the required corrosion resistance of the laminate, may be added for viscosity control.

NOTE 3—The addition of a thixotropic agent may reduce the resistance of many resin systems to certain corrosive chemical environments. It is the responsibility of the fabricator, using a thixotropic agent in the resin required for 7.1.1 and 7.1.2, to ascertain its compatibility with the corrosive environment when this has been reported by the purchaser.

5.1.1.2 Resin pastes used to fill crevices before overlay shall not be subject to the limitation of 5.1.1.

5.1.1.3 Resin may contain pigment, dyes, or colorants when agreed upon between fabricator and purchaser.

NOTE 4—The addition of pigment, dyes, or colorants may interfere with visual inspection of laminate quality.

5.1.1.4 Ultraviolet absorbers may be added for improved weather resistance if agreed upon between the fabricator and the purchaser.

5.1.1.5 Antimony compounds or other fire-retardant agents may be added to halogenated resins for improved fire resistance, if agreed upon between the fabricator and the purchaser.

NOTE 5—Because the addition of fire-retardant agents may interfere with visual inspection of laminate quality, they should not be used in the inner surface (7.1.1) or interior layer (7.1.2), unless their functional advantages would outweigh the loss of visual inspection.

5.2 *Reinforcement:*

5.2.1 *Chopped-Strand Mat*—Chopped-strand mat shall be constructed from chopped commercial-grade E-type glass strands bonded together using a binder. The strands should be treated with a sizing that is chemically compatible with the resin system used.

<sup>4</sup> Available from American National Standards Institute (ANSI), 25 W. 43rd St., 4th Floor, New York, NY 10036, <http://www.ansi.org>.

NOTE 6—The selection of the particular chopped-strand mat is dependent upon the performance characteristics required of the finished product and upon the processing techniques to be used.

5.2.2 *Nonwoven Biaxial or Unidirectional Fabric*—These products shall be a commercial grade of E-type glass fiber with a sizing that is chemically compatible with the resin system used.

5.2.3 *Woven Roving*—Woven roving shall be in accordance with Specification **D2150**.

5.2.4 *Surface Mat*—The reinforcement used for the inner surface (7.1.1) shall be either a commercial-grade chemical resistant glass surface mat or an organic-fiber surface mat. In environments that attack glass, the use of an organic-fiber surface mat is required.

## 6. Design Requirements

6.1 *Straight Shell*—The minimum required wall thickness of the cylindrical straight shell at any fluid level shall be determined by the following equation, but shall not be less than  $\frac{3}{16}$  in.:

$$t = PD/2S_H = 0.036 \gamma HD/2S_H \text{ or } (0.2489 \gamma HD/2S_H)$$

where:

$t$  = wall thickness, in. (mm),

$S_H$  = allowable hoop tensile stress (not to exceed  $\frac{1}{10}$  of the ultimate hoop strength), psi (kPa) (see 11.8),

$P$  = pressure, psi (kPa),

$H$  = fluid head, in. (mm),

$\gamma$  = specific gravity of fluid, and

$D$  = inside diameter of tank, in. (mm).

NOTE 7—The use of an accepted analytical technique, such as laminated plate theory (LPT), for design and analysis of composite vessels may predict stresses, strains, and strength on a ply-by-ply basis, given some basic lamina properties.

NOTE 8—The calculation is suitable for the shell design of elevated dished-bottom tanks that are mounted or supported below the tangent of the dished-bottom head. Special consideration must be given to the loading on the straight shell at the support when tank has mounting supports located above the tangent line.

NOTE 9—Table X2.1, Appendix X2, illustrates minimum straight-shell wall thicknesses.

### 6.2 Design for External Pressure:

6.2.1 *Cylindrical Shells*—For cylindrical shells, compute the value  $1.73 (D_o/L)^{0.5}$ . If the result is less than  $L/D_o$  of the cylinder, compute  $P_a$  as follows:

$$P_a = 2.6(E/F)(D_o/L)(t/D_o)^{2.5}$$

If the result is greater than  $L/D_o$  of the cylinder, compute  $P_a$  as follows:

$$P_a = \frac{2.6(E/F)(D_o/L)(t/D_o)^{2.5}}{(L/D_o) - 0.45(t/D_o)^{0.5}}$$

where:

$D_o$  = outside diameter, in.,

$E_t$  = hoop tensile modulus of the filament wound structural laminate, psi (kPa),

$F$  = design factor = 5,

$L$  = design length, in. (mm), of a vessel section, taken as the largest of the following: (a) the distance between head tangent lines plus one-third the depth of each formed head, if there are no stiffening rings (excluding conical heads and sections); (b) the distance between cone-to-cylinder junctions for vessels with a cone or conical heads if there are no stiffening rings; (c) the greatest center-to-center distance between any two adjacent stiffening rings; (d) the distance from the center of the first stiffening ring to the formed head tangent line plus one-third the depth of the formed head (excluding conical heads and sections), all measured parallel to the axis of the vessel; (e) the distance from the first stiffening ring in the cylinder to the cone-to-cylinder junction,

$P_a$  = allowable external pressure, psi (kPa), and

$t$  = wall thickness, in. (mm) (nominal).

6.2.2 *Torispherical Heads*—For torispherical heads, compute the allowable external pressure,  $P_a$ , as follows:

$$P_a = 0.36(E/F)(t/R_o)^2$$

where:

$R_o$  = outside crown radius of head, in. (mm).

For torispherical heads subject to internal loading, the knuckle radius shall be externally reinforced in accordance with Fig. 1. The reinforcement thickness shall be equal to the thickness of the head as calculated above. The thickness of a joint overlay near the knuckle radius tangent line of dished head contributes to the knuckle reinforcement.

6.2.3 *Stiffening Rings*—The required moment of inertia,  $I_s$ , of a circumferential stiffening ring for cylindrical shells under external pressure or internal vacuum shall not be less than that determined by the following:

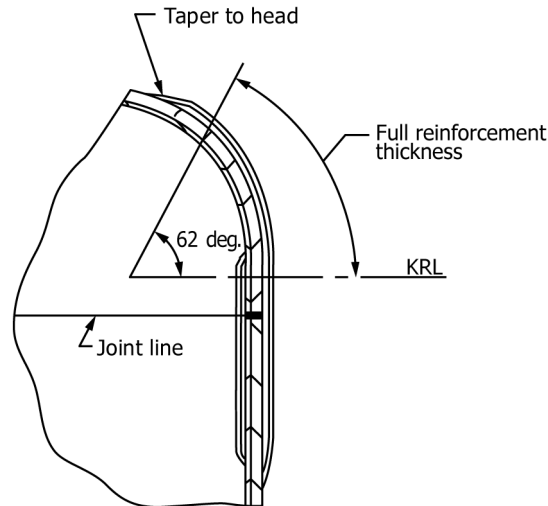

FIG. 1 Jointed Head Detail (Sketch A)

$$I_s = PL_s D^3 F / 24 E_h$$

where:

$D_o$  = shell outside diameter, in. (mm),

$E_h$  = hoop tensile modulus, psi (kPa),

$F$  = design factor = 5,

$I_s$  = moment of inertia, in.<sup>4</sup>(mm<sup>4</sup>), of stiffener for the effective length of shell,  $L_s$ ,

$L_s$  = one-half of the distance from the centerline of the stiffening ring to the next line of support on one side, plus one-half of the centerline distance to the next line of support on the other side of the stiffening ring, both measured parallel to the axis of the cylinder, in. A line of support is the following: (a) a stiffening ring that meets the requirements of this paragraph; (b) a circumferential line on a head at one-third the depth of the head tangent line; (c) a cone-to-cylinder junction,

$P$  = actual external pressure, psi (kPa).

Typical half-round stiffener sizes and dimensions for different values of  $I_s$  are shown in Fig. 4. Other stiffener profiles meeting the required moment of inertia may be used.

6.3 **Top Head**—The top head, regardless of shape, shall be able to support a 250-lb (113.4 kg) load on a 4 by 4-in. (100 by 100 mm) area without damage and with a maximum deflection of ½ % of the tank diameter.

6.3.1 The minimum thickness of the top head shall be ⅜ in. (4.8 mm).

NOTE 10—Support of auxiliary equipment, snow load, or operating personnel, may require additional reinforcement or the use of stiffening ribs, or both, sandwich construction, or other stiffening systems.

#### 6.4 Bottom Head:

6.4.1 The minimum thickness for a fully supported flat-bottom head shall be as follows:

⅜ in. (4.8 mm) for 2 to 6-ft (0.6 to 1.8-m) diameter,

¼ in. (6.4 mm) for over 6 to 12-ft (1.8 to 3.7-m) diameter, and

⅜ in. (9.5 mm) for over 12-ft (3.7-m) diameter.

6.4.2 Bottom heads may be molded integrally with the straight-shell, or may be molded separately with a straight flange length for subsequent joining to shell.

6.4.3 The radius of the bottom knuckle of a flat-bottom tank shall be not less than 1 in. (25 mm) on tanks 4 ft or smaller in diameter and 1.5 in. (38 mm) on tanks larger than 4 ft in diameter. The minimum thickness of the radiused section shall be equal to the combined thickness of the shell wall and the bottom. The reinforcement of the knuckle-radius area shall taper so that it is tangent to the flat bottom, and shall not extend beyond the tangent line onto the tank bottom, unless methods of manufacture are used that maintain flat-bottom configuration, and shall extend up the vertical tank wall a minimum of length “ $L$ ” of 8 in. (203 mm) on tanks up to 4 ft (1219 mm) in diameter, and 12 in. (304 mm) on tanks over 4 ft (1219 mm) in diameter. The reinforcement shall then taper into the side wall over an additional length “ $M$ ” of 4 in. (102 mm) (see Fig. 2). Methods of manufacture that incorporate stiffening bands as a means of knuckle stabilization, are permissible alternatives by agreement between purchaser and fabricator, provided that the fabricator can document the validity of design.

6.4.4 The tank bottom shall not have variations from a nominally flat plane that would prevent uniform contact of the entire bottom surface with a properly prepared support surface when the tank is filled with liquid. The bottom laminate surface shall be

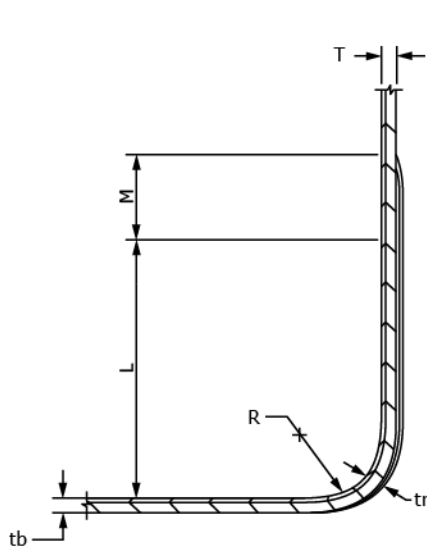

Tank bottom must be flat over entire width.

Figure 1A  
For Integral Head to Shell

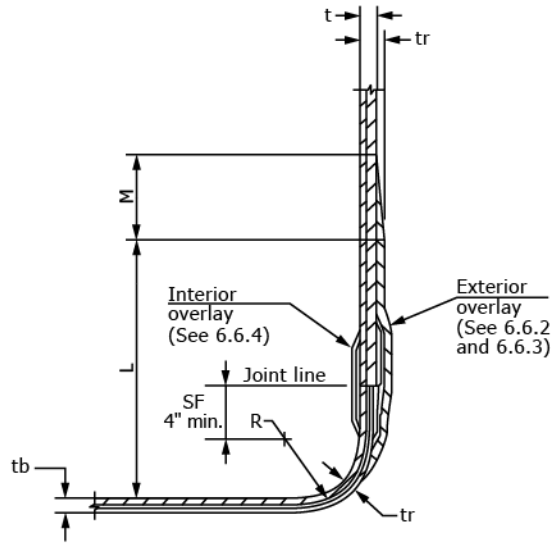

Tank bottom must be flat over entire width.

Figure 1B  
For Integral Head to Shell

Tank Dia. ft. (m)	R Min. in. (mm)	L Min. in. (mm)	M Min. in. (mm)
4(1.2) and under	1 (25.4)	8 (203)	3 (24)
over 4(1.2)	1 1/2 (38)	12 (305)	4 (102)

- L = Length of double reinforcing
- M = Length of thickness transition (taper)
- t = Shell thickness
- tb = Bottom thickness
- R = Inside corner radius
- SF = Straight flange of bottom head
- tr(min.) = t + tb

FIG. 2 Flat-Bottom Tank Corner Detail

a hand-work finish and shall have no excessive laminate projections that would prevent uniform contact with a properly prepared flat support surface when the tank is filled with liquid.

NOTE 11—This requirement is not intended to exclude the use of drain nozzles, which are commonly used at the bottom of the side shell. However, foundation cut-outs are required of the appropriate dimensions for nozzle type and size.

6.4.5 The thickness of an elevated torispherical dished bottom, suitable for supporting the weight of the fluid head, shall be determined by the following equation, but shall not be less than 3/16 in. (4.8 mm):

$$t = 0.885 PR/S = 0.885 (0.036 \gamma HR)/Sor (0.885 (0.2489 \gamma HR)/S)$$

where:

- t = thickness, in. (mm),
- S = allowable stress (not to exceed 1/10 of ultimate strength), psi (kPa) (see 11.8),
- γ = specific gravity of fluid,
- P = pressure, psi (kPa),
- R = inside radius of dished head, in. (mm), and
- H = distance from the top of the fluid to the deepest portion of the bottom, in. (mm).

NOTE 12— An alternate method for design of an elevated torispherical dished bottom is shown in Appendix X3.

6.4.5.1 Minimum thickness of ellipsoidal heads, (2:1) shall be calculated as follows:

$$t = \frac{PD}{2S}$$

6.4.5.2 Minimum thickness of conical heads shall be calculated as follows:

$$t = \frac{PD}{2S \cdot \cos(\alpha)}$$

where:

- α = 1/2 of APEX angle of the cone at the centerline of the head (not to exceed 30°).

6.4.6 The torispherical dished-bottom head shall have a radius of curvature that is equal to or less than the inside diameter of the tank straight shell, and a minimum knuckle radius of at least 6 % of the diameter of the head.

6.4.7 Deflection of the flat bottom when the tank is empty, commonly known as “oil canning,” is permissible as long as the requirements of 6.4.4 are met.

6.5 *Open-Top Tanks*—The top edge of open-top tanks shall have a horizontal reinforcing flange or other means of reinforcement sufficiently rigid to maintain the shape of the tank after installation. The flange shall be in accordance with Table 1. See Table 2.

6.6 *Joints:*

6.6.1 The cured resin surfaces to be overlaid shall be roughened using 36 or coarser grit abrasive media. The roughened area shall extend beyond the lay-up area so that no reinforcement is applied to an unroughened surface. Surfaces shall be clean and dry before lay-up. The entire roughened area shall be coated with paraffinated resin after the joint lay-up is made.

6.6.2 The secondary laminate joints are used to join hoop segments of the straight shell, or to join the bottom or top head to the shell. The thickness of the structural joint overlay shall be equal to the shell thickness as determined in 6.1.

6.6.3 The minimum width of the structural joint overlay for bottom supported tanks is shown in Table 3.

6.6.4 The corrosion-resistant barrier component of the joint shall be formed in the same manner as the inner surface and the interior layer (7.1.1 and 7.1.2) and shall not be considered a structural element in determining joint thickness. The minimum overlay width shall be 4 in. (100 mm).

6.6.5 The thickness of a joint near the bottom tangent line shall not be considered to contribute to the knuckle reinforcement of 6.4.3, but shall be additive thereto.

6.7 *Fittings:*

6.7.1 The more common method of fabricating nozzles is by contact molding both the nozzle neck and flange to the dimensions shown in Table 4. The corrosion-resistant barrier of the nozzle shall be at least equivalent to the inner surface and interior layer (7.1.1 and 7.1.2) and shall be fabricated from the same resin as the tank head or shell to which it is attached.

6.7.2 Acceptable alternative methods are the use of contact-molded pipe, filament-wound pipe in accordance with Specification D2996, or centrifugally cast pipe in accordance with Specification D2997, joined to a suitable contact-molded (Specification D5421), compression-molded, or filament-wound flange (Specification D4024). The corrosion-resistant barrier of the contact molded portions of such nozzles shall be equivalent to the inner surface and interior layer (7.1.1 and 7.1.2) and shall be fabricated from the same resin as the tank head or shell to which it is attached.

6.7.3 Nozzles 4 in. (102 mm) and smaller shall be supported by a suitable gusseting technique using plate gussets or conical gussets, as shown in Fig. 3 and Fig. 4. Plate gussets, where needed, shall be evenly spaced around the nozzle and are to be added after complete assembly of nozzle on shell. Larger nozzles, subject to superimposed mechanical forces, require special consideration.

6.7.4 Manways installed in top heads may be of the flanged design or of a nonflanged design, as agreed upon between the fabricator and purchaser.

6.7.4.1 Side-shell manways shall be in accordance with 7.3.2 and 7.3.3.

6.7.4.2 Typical manway dimensions are shown in Table 5.

NOTE 13—Tanks over 6 ft (1.8 m) straight-shell may need both top- and side-shell opening manways for safety and maintenance considerations.

6.7.5 *Vents:*

6.7.5.1 Vents that discharge freely into the atmosphere shall be provided in all Type I closed-top tanks. Minimum vent size shall be sufficient to handle the flow displacement of all combined inlet or outlet nozzles without creating any pressure above atmospheric pressure, or any vacuum condition.

NOTE 14—Special vent sizing consideration should be given to the numerous operating situations that could otherwise cause a positive or a negative pressure in a closed tank. Since overfilling a closed tank with a top vent can cause it to be overpressurized, a suitably sized overflow or other appropriate protection may be required to prevent overpressuring the tank.

6.7.6 Type II tanks shall be designed to withstand the specified positive or negative pressures not to exceed 14 in. of water (355.6 mm). Special design consideration shall be given to buckling of tank wall and heads, the hold-down lug system, and top and bottom knuckle requirements. Fluid level in the tank is an important consideration in the analysis.

6.7.6.1 Flat-bottom tanks shall have all hold-down lugs properly secured to the foundation, in accordance with the tank fabricator’s recommendation for the design of the lugs used and for the tank installation and operation.

**TABLE 1 Minimum Acceptable Contact Molded Laminate Physical Properties**

Property	Thickness, in. (mm)			
	1/8 to 3/16 (3.2 to 4.8)	1/4 (6.4)	3/16 (7.9)	3/8 and up (9.5 and up)
Ultimate tensile strength, min, psi (kPa)	9 000 (620.5)	12 000 (827.4)	13 000 (930.8)	15 000 (1 034)
Flexural strength, min, psi (kPa)	16 000 (1 103)	19 000 (1 310)	20 000 (1 399)	22 000 (1 517)
Flexural modulus for elasticity (tangent), psi (kPa)	700 000 (48 263)	800 000 (55 158)	900 000 (62 053)	1 000 000 (68 948)