



# Standard Specification for “Fiberglass” (Glass-Fiber-Reinforced Thermosetting-Resin) Pipe Fittings for Nonpressure Applications<sup>1</sup>

This standard is issued under the fixed designation D3840; the number immediately following the designation indicates the year of original adoption or, in the case of revision, the year of last revision. A number in parentheses indicates the year of last reapproval. A superscript epsilon ( $\epsilon$ ) indicates an editorial change since the last revision or reapproval.

## 1. Scope\*

1.1 This specification covers fiberglass pipe fittings intended for use in gravity flow systems for conveying sanitary sewage, storm water, and those industrial wastes for which the fittings are determined to be suitable. Elbows, tees, laterals, crosses, reducers, and adapters are included. Both glass-fiber-reinforced thermosetting-resin pipe (RTRP) and glass-fiber-reinforced polymer mortar pipe (RPMP) are fiberglass pipes.

NOTE 1—For the purposes of this standard, polymer does not include natural polymers.

1.2 This specification is intended to cover only dimensions, material properties, and workmanship rather than the structural design of the fittings. The structural design of the fittings shall be as agreed upon between purchaser and supplier, and needs to take into consideration the anticipated conditions of installation and service.

1.3 This specification covers only fittings fabricated from cut sections of pipe, or from a combination of pipe sections and contact molded (hand layup), or machine fabricated components.

1.4 The values stated in inch-pound units are to be regarded as the standard. The values given in parentheses are provided for information purposes only.

1.5 The following safety hazards caveat pertains only to the test method portion, Section 11, of this specification. *This standard does not purport to address all of the safety concerns, if any, associated with its use. It is the responsibility of the user of this standard to establish appropriate safety, health, and environmental practices and determine the applicability of regulatory limitations prior to use.*

NOTE 2—There is no known ISO equivalent to this standard.

1.6 *This international standard was developed in accordance with internationally recognized principles on standardization established in the Decision on Principles for the Development of International Standards, Guides and Recommendations issued by the World Trade Organization Technical Barriers to Trade (TBT) Committee.*

## 2. Referenced Documents

2.1 *ASTM Standards:*<sup>2</sup>

D638 Test Method for Tensile Properties of Plastics

D883 Terminology Relating to Plastics

D1600 Terminology for Abbreviated Terms Relating to Plastics

D1763 Specification for Epoxy Resins

D2290 Test Method for Apparent Hoop Tensile Strength of Plastic or Reinforced Plastic Pipe

D3262 Specification for “Fiberglass” (Glass-Fiber-Reinforced Thermosetting-Resin) Sewer Pipe

D3567 Practice for Determining Dimensions of “Fiberglass” (Glass-Fiber-Reinforced Thermosetting Resin) Pipe and Fittings

D3892 Practice for Packaging/Packing of Plastics

F412 Terminology Relating to Plastic Piping Systems

F477 Specification for Elastomeric Seals (Gaskets) for Joining Plastic Pipe

<sup>1</sup> This specification is under the jurisdiction of ASTM Committee D20 on Plastics and is the direct responsibility of Subcommittee D20.23 on Reinforced Plastic Piping Systems and Chemical Equipment.

Current edition approved April 1, 2014/Aug. 1, 2019. Published April 2014/August 2019. Originally approved in 1979. Last previous edition approved in 2014 as D3840—10: D3840 – 14. This specification replaces Specification D4160. DOI: 10.1520/D3840-14.10.1520/D3840-19.

<sup>2</sup> For referenced ASTM standards, visit the ASTM website, www.astm.org, or contact ASTM Customer Service at service@astm.org. For Annual Book of ASTM Standards volume information, refer to the standard’s Document Summary page on the ASTM website.

\*A Summary of Changes section appears at the end of this standard

### 3. Terminology

#### 3.1 Definitions:

3.1.1 *General*—Definitions are in accordance with Terminologies **D883** and **F412**. Abbreviations are in accordance with Terminology **D1600**, unless otherwise indicated.

#### 3.2 Definitions of Terms Specific to This Standard:

3.2.1 *fiberglass pipe*—a tubular product containing glass fiber reinforcements embedded in or surrounded by cured thermosetting resin. It is acceptable for the composite structure to contain aggregate, granular or platelet fillers, thixotropic agents, pigments or dyes. It is acceptable to include thermoplastic or thermosetting liners or coatings.

3.2.2 *reinforced polymer mortar pipe*—a fiberglass pipe with aggregate.

3.2.3 *reinforced thermosetting resin pipe*—a fiberglass pipe without aggregate.

3.2.4 *qualification*—One or more tests used to prove the design of a product. Not a routine quality control test.

NOTE 3—Qualification requirements appear in **6.1**, **7.2**, and **12.3**.

### 4. Materials

#### 4.1 Laminating Resin:

4.1.1 *Type 1*—Polyester thermosetting resin, with or without fillers or thixotropic agents or both.

NOTE 4—For the purpose of this standard, polyester includes vinyl ester resins.

4.1.2 *Type 2*—Epoxy resin, conforming to the requirements of Specification **D1763**, with or without fillers or thixotropic agents, or both.

#### 4.2 Reinforcement:

4.2.1 *Grade 1*—A commercial grade of glass fibers with a polyester-compatible finish.

4.2.2 *Grade 2*—A commercial grade of glass fibers with an epoxy-compatible finish.

4.3 *Gaskets*—The elastomeric gaskets used with the fittings joined to pipe shall conform to the requirements of Specification **F477**.

### 5. Fabrication

#### 5.1 Permissible Components:

5.1.1 Fittings covered under this specification shall be fabricated from cut section of pipe that conform to the requirements of Specification **D3262**, or from a combination of such pipe sections and contact molded (hand layup) or machine fabricated components.

5.1.2 It is acceptable to incorporate saddles, wrappers, necked flanges, and other components of metal or other dissimilar materials, as agreed upon between purchaser and supplier, provided the materials of such components are resistant to the corrosive effects of the internal and external environments anticipated in service, or are lined or coated or both with materials that provide equivalent protection.

#### 5.2 Bonding and Laminate Overlay Reinforcements:

5.2.1 Sections of the fitting shall be aligned and bonded together using polyester (Type 1) or epoxy (Type 2) resin materials with or without fiberglass reinforcement. Fiberglass reinforcement materials shall be compatible with the laminating resin; Grade 1 reinforcements shall be used with Type 1 laminating resin, and Grade 2 reinforcements shall be used with Type 2 laminating resin.

5.2.2 It is acceptable to apply laminated reinforcing overlays of bonded seams to either the outside or inside surface of the fitting, or to both inside and outside surfaces. The laminate shall be of chemically resistant construction suitable for the purpose and shall provide the additional strength necessary to meet the physical requirements shown in **Table 1**. Finished seam overlays shall be built up in two or more successive layers of reinforcement and shall be as crevice free as described in this paragraph and **5.2.3**. The width of the first layer shall be 2 in. (50 mm) minimum. Successive layers shall increase uniformly in width to provide the specified minimum total width of overlay that shall be centered on the seam. **Table 1** shows minimum widths of overlays required. The ends of each layer of reinforcement shall be overlapped a minimum of 1 in. (25 mm). Crevices between joined sections shall be filled with a filled resin paste, leaving a smooth inner surface. The interior of the seams shall also be sealed by covering with not less than a 0.03 in. (0.76 mm) thickness of reinforced resin-rich surface that provides corrosion resistance suitable for the intended service. Alternatively, when it is necessary to fabricate a fitting where the size and configuration do not allow adequate access to interior seams, the cut edges of sections shall be sealed prior to assembly and any reinforcing overlay protected by a resin-rich surface that provides corrosion resistance suitable for the intended service.

5.2.3 Components of dissimilar materials, such as steel to polyester or epoxy laminates, or polyester to epoxy laminates, shall be bonded with a resin compound capable of adhering to both materials. The resin compound shall contact the joining surfaces of both components with the spaces between the components filled. The excess resin compound that extrudes from the seam shall be removed, leaving a smooth fillet. Sealing laminates and reinforcing overlays shall be applied where required (see **5.1.1**, **5.2.1**, and **5.2.2**).

**TABLE 1 Minimum Properties of Structural Laminates**

Nominal Diameter, in. (mm)	Minimum Hoop Tensile Strength, lbf/in. (kN/m) of width <sup>A</sup>	Minimum Axial Tensile Strength, lbf/in. (kN/m) of circumference <sup>A</sup>	Minimum Total Width of Overlay, in. (mm) <sup>B</sup>
8 (203)	1600 (280)	1600 (280)	4 (100)
10 (254)	1600 (280)	1600 (280)	4 (100)
12 (305)	1600 (280)	1600 (280)	4 (100)
14 (356)	1600 (280)	1600 (280)	4 (100)
15 (381)	1600 (280)	1600 (280)	4 (100)
16 (406)	1600 (280)	1600 (280)	4 (100)
18 (457)	1600 (280)	1600 (280)	4 (100)
20 (508)	1600 (280)	1600 (280)	4 (100)
21 (533)	1600 (280)	1600 (280)	4 (100)
24 (610)	1600 (280)	1600 (280)	4 (100)
27 (686)	1600 (280)	1600 (280)	4 (100)
30 (762)	1600 (280)	1600 (280)	4 (100)
33 (838)	1700 (300)	1700 (300)	6 (150)
36 (914)	1800 (315)	1800 (315)	6 (150)
39 (991)	2000 (350)	2000 (350)	6 (150)
42 (1067)	2100 (368)	2100 (368)	6 (150)
45 (1143)	2300 (403)	2300 (403)	6 (150)
48 (1219)	2400 (420)	2400 (420)	8 (200)
51 (1295)	2600 (455)	2600 (455)	8 (200)
54 (1372)	2700 (473)	2700 (473)	8 (200)
60 (1524)	3000 (525)	3000 (525)	8 (200)
66 (1676)	3300 (578)	3300 (578)	10 (250)
72 (1829)	3600 (630)	3600 (630)	10 (250)
78 (1981)	3900 (683)	3900 (683)	10 (250)
84 (2134)	4200 (736)	4200 (736)	12 (300)
90 (2286)	4500 (788)	4500 (788)	12 (300)
96 (2438)	4800 (841)	4800 (841)	14 (350)
102 (2591)	5100 (893)	5100 (893)	16 (400)
108 (2743)	5400 (946)	5400 (946)	16 (400)
114 (2896)	5700 (998)	5700 (998)	16 (400)
120 (3048)	6000 (1051)	6000 (1051)	16 (400)
132 (3353)	6600 (1156)	6600 (1156)	18 (450)
144 (3658)	7200 (1261)	7200 (1261)	20 (500)
156 (3962)	7800 (1366)	7800 (1366)	22 (550)

<sup>A</sup>The values given are minimums only. Sound engineering practice dictates that all fittings be designed to withstand the loads and conditions anticipated in the service for which they are intended.

<sup>B</sup>The dimensions given are minimums for “butt-and-strap” type joints.

[ASTM D3840-19](https://standards.iteh.ai/catalog/standards/sist/43c2dedd-ea6a-4c08-84bd-40d7a54e325b/astm-d3840-19)

<https://standards.iteh.ai/catalog/standards/sist/43c2dedd-ea6a-4c08-84bd-40d7a54e325b/astm-d3840-19>

## 6. Joints

6.1 The fitting joints shall be coupling or bell-and-spigot in accordance with the joint requirements of Specification **D3262**, unless otherwise specified. It is acceptable to qualify joint designs on straight sections of pipe.

## 7. Physical Requirements

7.1 Properties of structural laminates, used either as seam reinforcing overlays or as contact molded or machine fabricated components, other than cut sections of pipe, shall be as shown in **Table 1**, when tested in accordance with **11.1**.

7.2 *Shear Strength*—The minimum shear strength of seam reinforcing overlays shall be 500 psi (3.45 MPa) when tested in accordance with **11.2**.

## 8. Dimensions and Permissible Variations

8.1 *Wall Thickness*—The wall thickness of any area of the fitting furnished under this specification shall not at any point be less than 87.5 % of the nominal wall thickness published in the manufacturers’ literature current at the time of purchase when measured in accordance with **11.3.1**.

8.2 *Fitting Diameters*—Fittings shall be supplied in nominal diameters as given in Specification **D3262**. The fitting diameter tolerances shall be as given in Specification **D3262**, when measured in accordance with **11.3.2** or **11.3.3** as applicable.

8.3 *Lengths*—The tolerance for the laying length and other significant dimensions shall be  $\pm 2$  in. ( $\pm 51$  mm) or  $\pm 1$  % of the dimension, whichever is greater, when measured in accordance with **11.3.4**. See **Tables 2-6** and **Figs. 1 and 2** for typical minimum laying lengths.

8.4 *Angular Dimensions*—Angular dimensions shall have a tolerance of  $\pm 1^\circ$  when measured in accordance with ~~11.3.4~~ **11.3.5**.

TABLE 2 0° to 30° Elbow<sup>A</sup>

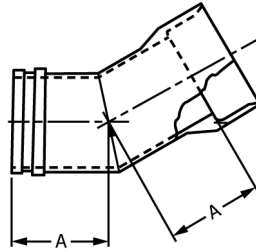

Pipe Size, in. (mm)	Dimension A <sup>B</sup> , in. (mm)
8 (203)	12 (305)
10 (254)	13 (330)
12 (305)	13 (330)
14 (356)	14 (356)
15 (381)	14 (356)
16 (406)	15 (381)
18 (457)	15 (381)
20 (508)	16 (406)
21 (533)	16 (406)
24 (610)	17 (432)
27 (686)	17 (432)
30 (762)	18 (457)
33 (838)	18 (457)
36 (914)	20 (508)
39 (991)	21 (533)
42 (1067)	22 (559)
45 (1143)	23 (584)
48 (1219)	24 (610)
54 (1372)	25 (635)
60 (1524)	26 (660)
66 (1676)	29 (737)
72 (1829)	29 (737)
78 (1981)	30 (762)
84 (2134)	34 (864)
90 (2286)	36 (914)
96 (2438)	38 (965)
102 (2591)	39 (991)
108 (2743)	41 (1041)

<sup>A</sup> Fitting end configurations other than the typical bell and spigot shown in the figure are acceptable as agreed upon between manufacturer and purchaser. Refer to Section 6.

<sup>B</sup> Dimensions given are typical minimum laying lengths. Laying lengths for fittings larger than 108 in. diameter shall be as agreed upon between purchaser and supplier.

## 9. Workmanship, Finish, and Appearance

9.1 The inside surfaces of each fitting shall blend smoothly and shall be free of bulges, dents, ridges, or other irregularities that result in a variation of more than 1/8 in. (3.2 mm) from that obtained on adjacent portions of the surface.

NOTE 5—This requirement is concerned with roughness and waviness and does not apply to diameter tolerances or thickness of internal seam reinforcement if present. See 8.2 for inside diameter tolerances, including internal reinforcement.

9.2 Joint sealing surfaces shall be free of dents, gouges, cracks, and other surface imperfections that will affect the integrity of the joints.

9.3 The inner surface of each reinforced plastic fitting component and connecting seam shall be composed of resin with or without reinforcement, aggregate, or filler. No glass fiber-reinforcement shall penetrate the interior surface of the fitting wall.

9.4 Internal and external reinforcements shall be free of voids, dry spots, cracks, and crazing. Some waviness in the internal reinforcement is permissible so long as the surface is smooth. Unless otherwise agreed upon between purchaser and supplier, all fittings shall meet the visual and repair criteria of Tables 7 and 8.

9.5 Fittings shall show good workmanship, including uniformity from item to item.

TABLE 3 31° to 60° Elbow<sup>A</sup>

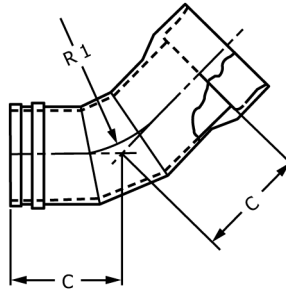

Pipe Size, in. (mm)	Dimension C <sup>B</sup> , in. (mm)	R1 (45°), in. (mm)
8 (203)	18.5 (470)	12.0 (305)
10 (254)	19.5 (495)	15.0 (381)
12 (305)	20.5 (521)	18.0 (457)
14 (356)	22.0 (559)	21.0 (533)
15 (381)	22.5 (572)	22.5 (572)
16 (406)	23.0 (584)	24.0 (610)
18 (457)	25.0 (635)	27.0 (686)
20 (508)	25.5 (648)	30.0 (762)
21 (533)	26.0 (660)	31.5 (800)
24 (610)	27.5 (699)	36.0 (914)
27 (686)	28.5 (724)	40.5 (1029)
30 (762)	31.0 (787)	45.0 (1143)
33 (838)	33.0 (838)	49.5 (1257)
36 (914)	34.5 (876)	54.0 (1372)
39 (991)	36.5 (927)	58.5 (1486)
42 (1067)	38.0 (965)	63.0 (1600)
45 (1143)	40.5 (1029)	67.5 (1715)
48 (1219)	41.5 (1054)	72.0 (1829)
54 (1372)	45.0 (1143)	81.0 (2057)
60 (1524)	48.5 (1232)	90.0 (2286)
66 (1676)	52.0 (1321)	99.0 (2515)
72 (1829)	55.5 (1410)	108.0 (2743)
78 (1981)	59.0 (1499)	117.0 (2972)
84 (2134)	62.5 (1588)	126.0 (3200)
90 (2286)	66.5 (1689)	135.0 (3429)
96 (2438)	70.0 (1778)	144.0 (3658)
102 (2591)	73.5 (1867)	153.0 (3886)
108 (2743)	77.0 (1956)	162.0 (4115)

<sup>A</sup>Fitting end configurations other than the typical bell and spigot shown in the figure are acceptable as agreed upon between the manufacturer and purchaser. Refer to Section 6.

<sup>B</sup>Dimensions given are typical minimum laying lengths. Laying lengths for fittings larger than 108 in. diameter shall be as agreed upon between purchaser and supplier.

## 10. Sampling

10.1 *Lot*—Unless otherwise agreed upon between purchaser and supplier, one lot shall consist of 100 fittings of each type, grade, and construction of laminate overlay reinforcement, or contact molded or machine fabricated component, or both.

10.2 *Unit Sample*—Select one fitting from each lot. Prepare a sample or representative laminate and test specimens to determine conformance with the requirements of 7.1 for ultimate tensile strength.

## 11. Test Methods

11.1 *Ultimate Tensile Strength*—Determine the ultimate tensile strength of sample laminate specimens cut from seam reinforcing overlays or contact molded or machine fabricated components, or from specimens of a laminate fabricated to be consistent in every way with the construction used in the reinforcing overlay or component of the fitting. One or both of the following test methods shall be employed at the manufacturer's option:

11.1.1 *Test Method D2290*, using Type B specimens, except that the size of the specimens shall be permitted to be modified and speed of testing and rate of crosshead motion shall not apply. Record the load to fail of each specimen and determine the specimen width as close to the break as possible. Use the measured width and failure load to calculate the tensile strength.

TABLE 4 61° to 90° Elbow<sup>A</sup>

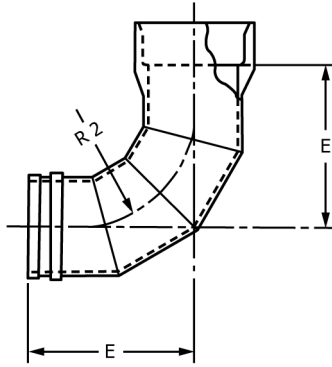

Pipe Size, in. (mm)	Dimension E <sup>B</sup> , in. (mm)	R2 (90°), in. (mm)
8 (203)	26.0 (660)	12.0 (305)
10 (254)	28.5 (724)	15.0 (381)
12 (305)	31.0 (787)	18.0 (457)
14 (356)	34.5 (876)	21.0 (533)
15 (381)	35.5 (902)	22.5 (572)
16 (406)	37.0 (940)	24.0 (610)
18 (457)	40.5 (1029)	27.0 (686)
20 (508)	43.0 (1092)	30.0 (762)
21 (533)	44.0 (1118)	31.5 (800)
24 (610)	46.0 (1219)	36.0 (914)
27 (686)	49.0 (1308)	40.5 (1029)
30 (762)	53.0 (1422)	45.0 (1143)
33 (838)	58.0 (1549)	49.5 (1257)
36 (914)	63.0 (1638)	54.0 (1372)
39 (991)	68.0 (1778)	58.5 (1486)
42 (1067)	71.0 (1854)	63.0 (1600)
45 (1143)	77.5 (1969)	67.5 (1715)
48 (1219)	80.0 (2070)	72.0 (1829)
54 (1372)	88.0 (2286)	81.0 (2057)
60 (1524)	95.0 (2489)	90.0 (2286)
66 (1676)	103.0 (2705)	99.0 (2515)
72 (1829)	115.0 (2921)	108.0 (2743)
78 (1981)	123.0 (3137)	117.0 (2972)
84 (2134)	131.5 (3340)	126.0 (3200)
90 (2286)	140.0 (3556)	135.0 (3429)
96 (2438)	148.5 (3772)	144.0 (3658)
102 (2591)	157.0 (3988)	153.0 (3886)
108 (2743)	165.5 (4204)	162.0 (4115)

<sup>A</sup>Fitting end configurations other than the typical bell and spigot shown in the figure are acceptable as agreed upon between the manufacturer and purchaser. Refer to Section 6.

<sup>B</sup>Dimensions given are typical minimum laying lengths. Laying lengths for fittings larger than 108 in. diameter shall be as agreed upon between purchaser and supplier.

11.1.2 *Test Method D638*, using flat Type I specimens, except that the specimens shall be the actual thickness of the reinforcing overlay or fabricated component and the other dimensions shall be suitable for the specimen thickness and the testing apparatus. Specimens shall be permitted to be machined on the edges, but shall not be machined on the surface. Tensile strength shall be the average of five specimens tested at a speed of 0.20 to 0.25 in. (5 to 6.4 mm)/min.

11.1.3 Conduct tests of anisotropic laminates to determine the ultimate tensile strength in both the hoop and axial directions. The ultimate tensile strength of isotropic laminates shall be permitted to be determined in either the hoop or axial direction.

11.2 *Minimum Shear Strength*—Determine the shear strength of axially oriented laminate specimens in accordance with 11.1.2, except that the specimens shall be representative of an overlay reinforced seam joining two cut sections of pipe in straight alignment (See Fig. 3). Calculate the shear strength by dividing the maximum load by the area of both sides of the pipe section covered by the reinforcing overlay on one side of the seam. If the specimen does not fail or if the failure occurs outside of the reinforced area, consider the results satisfactory provided the shear strength calculated from the maximum load exceeds 500 psi (3.45 MPa).