

# INTERNATIONAL STANDARD



**Passive RF and microwave devices, intermodulation level measurement –  
Part 6: Measurement of passive intermodulation in antennas**

(<https://standards.iteh.ai>)  
Document Preview

[IEC 62037-6:2021](https://standards.iteh.ai/catalog/standards/iec/6741ab1a-021e-4aa6-9dbb-869457376e54/iec-62037-6-2021)

<https://standards.iteh.ai/catalog/standards/iec/6741ab1a-021e-4aa6-9dbb-869457376e54/iec-62037-6-2021>



## THIS PUBLICATION IS COPYRIGHT PROTECTED

Copyright © 2021 IEC, Geneva, Switzerland

All rights reserved. Unless otherwise specified, no part of this publication may be reproduced or utilized in any form or by any means, electronic or mechanical, including photocopying and microfilm, without permission in writing from either IEC or IEC's member National Committee in the country of the requester. If you have any questions about IEC copyright or have an enquiry about obtaining additional rights to this publication, please contact the address below or your local IEC member National Committee for further information.

IEC Central Office  
3, rue de Varembe  
CH-1211 Geneva 20  
Switzerland

Tel.: +41 22 919 02 11  
[info@iec.ch](mailto:info@iec.ch)  
[www.iec.ch](http://www.iec.ch)

### About the IEC

The International Electrotechnical Commission (IEC) is the leading global organization that prepares and publishes International Standards for all electrical, electronic and related technologies.

### About IEC publications

The technical content of IEC publications is kept under constant review by the IEC. Please make sure that you have the latest edition, a corrigendum or an amendment might have been published.

#### IEC publications search - [webstore.iec.ch/advsearchform](http://webstore.iec.ch/advsearchform)

The advanced search enables to find IEC publications by a variety of criteria (reference number, text, technical committee, ...). It also gives information on projects, replaced and withdrawn publications.

#### IEC Just Published - [webstore.iec.ch/justpublished](http://webstore.iec.ch/justpublished)

Stay up to date on all new IEC publications. Just Published details all new publications released. Available online and once a month by email.

#### IEC Customer Service Centre - [webstore.iec.ch/csc](http://webstore.iec.ch/csc)

If you wish to give us your feedback on this publication or need further assistance, please contact the Customer Service Centre: [sales@iec.ch](mailto:sales@iec.ch).

#### IEC online collection - [oc.iec.ch](http://oc.iec.ch)

Discover our powerful search engine and read freely all the publications previews. With a subscription you will always have access to up to date content tailored to your needs.

#### Electropedia - [www.electropedia.org](http://www.electropedia.org)

The world's leading online dictionary on electrotechnology, containing more than 22 000 terminological entries in English and French, with equivalent terms in 18 additional languages. Also known as the International Electrotechnical Vocabulary (IEV) online.

International Standards  
standards.iteh.ai)  
Document Preview

[IEC 62037-6:2021](https://standards.iteh.ai/catalog/standards/iec/6741ab1a-021e-4aa6-9dbb-869457376e54/iec-62037-6-2021)

<https://standards.iteh.ai/catalog/standards/iec/6741ab1a-021e-4aa6-9dbb-869457376e54/iec-62037-6-2021>



IEC 62037-6

Edition 2.0 2021-11  
REDLINE VERSION

# INTERNATIONAL STANDARD



Passive RF and microwave devices, intermodulation level measurement –  
Part 6: Measurement of passive intermodulation in antennas

Document Preview

[IEC 62037-6:2021](https://standards.iteh.ai/catalog/standards/iec/6741ab1a-021e-4aa6-9dbb-869457376e54/iec-62037-6-2021)

<https://standards.iteh.ai/catalog/standards/iec/6741ab1a-021e-4aa6-9dbb-869457376e54/iec-62037-6-2021>

INTERNATIONAL  
ELECTROTECHNICAL  
COMMISSION

ICS 33.040.20

ISBN 978-2-8322-5120-1

**Warning! Make sure that you obtained this publication from an authorized distributor.**

## CONTENTS

FOREWORD .....	3
1 Scope .....	5
2 Normative references .....	5
3 Terms, definitions and abbreviated terms .....	5
3.1 Terms and definitions .....	5
3.2 Abbreviated terms .....	5
4 Definitions of antenna as it pertains to PIM .....	6
4.1 Antenna .....	6
4.2 Antenna under test .....	6
4.3 Active antenna .....	6
4.4 Antenna PIM .....	6
5 Antenna design and field installation considerations .....	6
5.1 Environmental effects on PIM performance .....	6
5.2 Antenna interface connection .....	6
5.3 Mounting considerations to avoid PIM generation .....	7
5.4 Neighbouring sources of interference .....	7
5.5 Standard practices and guidelines for material selection .....	7
6 PIM measurement considerations .....	7
6.1 Quality assurance process and handling procedures .....	7
6.2 Measurement accuracy .....	7
6.3 Test environment .....	8
6.4 Safety .....	8
6.5 Test set-up .....	8
6.5.1 Coaxial test cable assemblies .....	8
6.5.2 Defining a good low PIM reference load .....	8
6.5.3 Test set-up and test site baseline PIM verification .....	9
6.6 PIM test configurations .....	9
6.7 Combined environmental and PIM testing .....	11
6.7.1 General .....	11
6.7.2 Mechanical considerations .....	11
6.7.3 Test system cables and connectors .....	11
6.8 PIM test chamber design .....	11
6.8.1 General .....	11
6.8.2 RF absorber materials .....	12
6.8.3 Supporting structures and walls .....	12
6.8.4 RF shielding .....	12
7 Dynamic PIM measurement considerations .....	13
7.1 General .....	13
7.2 Dynamic testing methodology .....	13
7.3 Shocks test .....	13
Bibliography .....	15
Figure 1 – Antenna reverse PIM test set-up .....	10
Figure 2 – Antenna forward PIM test set-up .....	10
Figure 3 – Hammer description .....	14

## INTERNATIONAL ELECTROTECHNICAL COMMISSION

**PASSIVE RF AND MICROWAVE DEVICES,  
INTERMODULATION LEVEL MEASUREMENT –****Part 6: Measurement of passive intermodulation in antennas**

## FOREWORD

- 1) The International Electrotechnical Commission (IEC) is a worldwide organization for standardization comprising all national electrotechnical committees (IEC National Committees). The object of IEC is to promote international co-operation on all questions concerning standardization in the electrical and electronic fields. To this end and in addition to other activities, IEC publishes International Standards, Technical Specifications, Technical Reports, Publicly Available Specifications (PAS) and Guides (hereafter referred to as "IEC Publication(s)"). Their preparation is entrusted to technical committees; any IEC National Committee interested in the subject dealt with may participate in this preparatory work. International, governmental and non-governmental organizations liaising with the IEC also participate in this preparation. IEC collaborates closely with the International Organization for Standardization (ISO) in accordance with conditions determined by agreement between the two organizations.
- 2) The formal decisions or agreements of IEC on technical matters express, as nearly as possible, an international consensus of opinion on the relevant subjects since each technical committee has representation from all interested IEC National Committees.
- 3) IEC Publications have the form of recommendations for international use and are accepted by IEC National Committees in that sense. While all reasonable efforts are made to ensure that the technical content of IEC Publications is accurate, IEC cannot be held responsible for the way in which they are used or for any misinterpretation by any end user.
- 4) In order to promote international uniformity, IEC National Committees undertake to apply IEC Publications transparently to the maximum extent possible in their national and regional publications. Any divergence between any IEC Publication and the corresponding national or regional publication shall be clearly indicated in the latter.
- 5) IEC itself does not provide any attestation of conformity. Independent certification bodies provide conformity assessment services and, in some areas, access to IEC marks of conformity. IEC is not responsible for any services carried out by independent certification bodies.
- 6) All users should ensure that they have the latest edition of this publication.
- 7) No liability shall attach to IEC or its directors, employees, servants or agents including individual experts and members of its technical committees and IEC National Committees for any personal injury, property damage or other damage of any nature whatsoever, whether direct or indirect, or for costs (including legal fees) and expenses arising out of the publication, use of, or reliance upon, this IEC Publication or any other IEC Publications.
- 8) Attention is drawn to the Normative references cited in this publication. Use of the referenced publications is indispensable for the correct application of this publication.
- 9) Attention is drawn to the possibility that some of the elements of this IEC Publication may be the subject of patent rights. IEC shall not be held responsible for identifying any or all such patent rights.

**This redline version of the official IEC Standard allows the user to identify the changes made to the previous edition IEC 62037-6:2013. A vertical bar appears in the margin wherever a change has been made. Additions are in green text, deletions are in strikethrough red text.**

IEC 62037-6 has been prepared by IEC technical committee 46: Cables, wires, waveguides, RF connectors, RF and microwave passive components and accessories. It is an International Standard.

This second edition cancels and replaces the first edition published in 2013. This edition constitutes a technical revision.

This edition includes the following significant technical changes with respect to the previous edition:

- a) dynamic testing requirements updated to define impact energy and locations to apply impacts to devices under test;

The text of this International Standard is based on the following documents:

Draft	Report on voting
46/838/FDIS	46/859/RVD

Full information on the voting for its approval can be found in the report on voting indicated in the above table.

The language used for the development of this International Standard is English.

This document was drafted in accordance with ISO/IEC Directives, Part 2, and developed in accordance with ISO/IEC Directives, Part 1 and ISO/IEC Directives, IEC Supplement, available at [www.iec.ch/members\\_experts/refdocs](http://www.iec.ch/members_experts/refdocs). The main document types developed by IEC are described in greater detail at [www.iec.ch/standardsdev/publications](http://www.iec.ch/standardsdev/publications).

A list of all the parts in the IEC 62037 series, published under the general title *Passive RF and microwave devices, intermodulation level measurement* can be found on the IEC website.

The committee has decided that the contents of this document will remain unchanged until the stability date indicated on the IEC website under [webstore.iec.ch](http://webstore.iec.ch) in the data related to the specific document. At this date, the document will be

- reconfirmed,
- withdrawn,
- replaced by a revised edition, or
- amended.

**IMPORTANT – The 'colour inside' logo on the cover page of this publication indicates that it contains colours which are considered to be useful for the correct understanding of its contents. Users should therefore print this document using a colour printer.**

# PASSIVE RF AND MICROWAVE DEVICES, INTERMODULATION LEVEL MEASUREMENT –

## Part 6: Measurement of passive intermodulation in antennas

### 1 Scope

This part of IEC 62037 defines the test fixtures and procedures recommended for measuring levels of passive intermodulation generated by antennas, typically used in wireless communication systems. The purpose is to define qualification and acceptance test methods for antennas for use in low intermodulation (low IM) applications.

### 2 Normative references

~~The following documents, in whole or in part, are normatively referenced in this document and are indispensable for its application. For dated references, only the edition cited applies. For undated references, the latest edition of the referenced document (including any amendments) applies.~~

~~IEC 62037-1:2012, *Passive r.f. and microwave devices, intermodulation level measurement – Part 1: General requirements and measuring methods*~~

~~IEC 62037-3, *Passive r.f. and microwave devices, intermodulation level measurement – Part 3: Measurement of passive intermodulation in coaxial connectors*~~

There are no normative references in this document.

### 3 Terms, definitions and abbreviated terms

#### 3.1 Terms and definitions

No terms and definitions are listed in this document.

ISO and IEC maintain terminological databases for use in standardization at the following addresses:

- IEC Electropedia: available at <http://www.electropedia.org/>
- ISO Online browsing platform: available at <http://www.iso.org/obp>

#### 3.2 Abbreviated terms

AIM	Active intermodulation
AUT	Antenna under test
ESD	Electrostatic discharge
HPA	High power amplifier
IM	Intermodulation
LNA	Low noise amplifier
PIM	Passive intermodulation
RF	Radio frequency

## 4 Definitions of antenna as it pertains to PIM

### 4.1 Antenna

An antenna is that part of a radio transmitting or receiving system which is designed to provide the required coupling between a transmitter or a receiver and the medium in which the radio wave propagates.

The antenna consists of a number of parts or components. These components include, but are not limited to, one or many radiating elements, one or many RF interfaces, a distribution or combining feed network, internal support structures, devices which control or adjust the amplitude/phase response and distribution to the radiating element(s), filters, diplexers, orthomode transducers, polarizers, waveguides, coaxial cables or printed circuits. In addition, peripheral components could also influence the PIM performance of the antenna. These components ~~may~~ can include, but are not limited to, mounting brackets, mounting hardware, radome, radome fasteners, thermal insulation and grounding hardware.

### 4.2 Antenna under test

The antenna hardware can have an effect on the overall antenna PIM performance. Therefore, it is necessary to specify the hardware which is to be part of the antenna under test (AUT).

### 4.3 Active antenna

An active antenna incorporates active devices such as low noise amplifiers (LNAs), high power amplifiers (HPAs), phase shifters, etc. An active antenna has the additional concern of active intermodulation (AIM) which is typically at a much higher level than PIM. The measurement of PIM in the presence of AIM is not within the scope of this document. If required, the PIM measurement of an active antenna shall be performed on the passive portion of the antenna only.

### 4.4 Antenna PIM

The antenna PIM is defined as the PIM that is generated by the antenna assembly itself at a reference plane or RF interface. The PIM can be measured in a radiated or conducted (transmissive or reflective) mode.

## 5 Antenna design and field installation considerations

### 5.1 Environmental effects on PIM performance

Any hardware located in the nearby environment can significantly influence the PIM performance of an antenna or antenna system. The effect of ferromagnetic materials, dissimilar metallic junctions which are part of neighbouring hardware, such as other antennas, tower structures, aircraft fuselage components, spacecraft thermal control hardware, DC and ESD grounding hardware, non-high pressure mechanical connections, etc., can potentially have a detrimental effect on the PIM performance of the communication system.

### 5.2 Antenna interface connection

Any interface that is exposed to RF is a potential PIM source and shall be designed to be low PIM. Care shall be taken to ensure that all the mating surfaces are clean. The connections, whether coaxial or waveguide, should be inspected for dirt, metallic filings, sharp protruding material, and other potential contaminants. Any coaxial connections shall be torqued to the manufacturer's specifications to ~~assure~~ ensure proper metal-to-metal contact pressure is achieved. If waveguide is used, then the flange bolts shall be torqued to the recommended manufacturer's specifications. Careful attention shall be paid to the alignment of the mating coaxial connectors or waveguide flanges.



The materials and combination of materials used in the connectors, including plating, are important for the PIM performance. The use of a soft plating material (e.g. gold, silver, etc.) of sufficient thickness (several skin depths) over a hard-base material (brass, BeCu, etc.) is usually preferable. The number of interfaces (coaxial connectors and adapters) should be minimized. This will reduce the number of metal-to-metal junctions and, thus, the possibility of PIM generation. More information about coaxial connectors can be found in IEC 62037-3.

### 5.3 Mounting considerations to avoid PIM generation

The antenna shall be properly secured to its mounting bracket. All bolts and holding harnesses used to secure the antenna to its support structure shall be tightened and torqued according to the manufacturer's specifications. The coaxial or waveguide transmission line(s) leading to the antenna input port(s) shall also be well-secured and prohibited from rubbing or moving.

Care should be taken in the antenna placement by pointing it towards a clear sky view and to isolate it from all possible neighbouring sources of interference such as tower structures, nearby antennas, buildings, walls, aircraft fuselage, spacecraft platform, etc.

### 5.4 Neighbouring sources of interference

Knowledge of the RF environment in which the antenna is to be installed is important. Care should be taken in the antenna placement to isolate it from all possible neighbouring sources of interference. For instance, structures having low contact pressure or corroding parts should be avoided. Additionally, other antennas radiating in a similar band or in bands whose harmonics could fall within the receive frequency band of the antenna being installed also require consideration. Other electric or electronic devices ~~may~~ can emit interfering RF signals that fall into the receive frequency band of the antenna.

### 5.5 Standard practices and guidelines for material selection

IEC 62037-1:~~2012~~2021, Clause 6 serves as a guide for the design, selection of materials, and handling of components that ~~may~~ can be susceptible to PIM generation. It is very important to consider the application of the antenna, as there are large differences in acceptable PIM levels between space applications and terrestrial applications.

## 6 PIM measurement considerations

### 6.1 Quality assurance process and handling procedures

The purpose of Clause 6 is to provide guidance in the areas of quality control as it pertains to the performance of PIM testing of antenna products. Procedures are included to enhance the accuracy and ensure safety when performing PIM measurements on antenna products. The following guidelines will help minimize errors induced within the test system.

### 6.2 Measurement accuracy

The accuracy of PIM tests performed on antenna products ~~may~~ can be severely affected by a multitude of sources that ~~may~~ can be either external or internal to the test system. Some of the sources which can affect the results of PIM tests performed on antenna products include, but are not limited to, the following:

- a) objects comprising parts made of electrically conductive materials that are exposed to the electromagnetic fields radiated by the AUT;
- b) loose, damaged or corroded mounting hardware attached to the AUT;
- c) loose or corroded hardware exposed to the radiated RF fields from the AUT;
- d) radio frequency signals generated by external sources;
- e) faulty or poorly performing coaxial interface cables;
- f) dirty/contaminated/worn interface connections;

- g) improperly mated interface connections;
- h) poorly shielded RF interface connections;
- i) inadequately filtered AIM from the test set-up;
- j) consideration ~~should be given to~~ of input transmission line losses;
- k) contaminated absorbers.

### 6.3 Test environment

When applicable, PIM measurements ~~may~~ can be accomplished outdoors. In performing such a test, it is important to ensure that government regulations pertaining to the maximum authorized RF radiation levels are met. Also, the RF energy radiated from the AUT ~~may~~ can generate PIM in surrounding structures that may couple back into the antenna resulting in invalid PIM test results. Additionally, external sources of RF radiation ~~may~~ can interfere with the test measurements. A survey of the frequencies locally in use is recommended prior to testing. Many of the external sources of PIM ~~may~~ can be minimized or eliminated by performing the PIM testing of antennas within an anechoic test chamber providing a low PIM test environment. More information on the construction of anechoic test chambers suitable for PIM testing is provided in 6.8.

### 6.4 Safety

Performing PIM tests on antenna products can be dangerous. Potentially high voltages and high levels of RF energy ~~may~~ can be present both within the AUT and within the test environment. The AUT should be positioned such that personnel will not be exposed to electromagnetic fields exceeding the acceptable levels specified by government agencies.

### 6.5 Test set-up

#### 6.5.1 Coaxial test cable assemblies

A problem with PIM test set-ups using coaxial cable interfaces is the need to repeatedly connect/disconnect coaxial connectors. The following are some recommendations on test set-up procedures.

- a) Sealing O-rings at connector interfaces should be thoroughly cleaned or should preferably be avoided if possible. These O-rings accumulate metal filings, which can become a source of PIM.
- b) Inspect connectors, dielectric and interface mating surfaces or flanges for contamination, especially metallic debris, just prior to mating the interface. Also inspect connector mating surfaces for burrs, scratches, dents, and loss of plating. Proper installation and torquing of the hardware will minimize the generation of PIM within interface connections.
- c) Clean compressed air should be used to blow potential metal particles from the connector interfaces after each connect-disconnect cycle.
- d) Great care shall be taken to ensure that the cables have not been stressed or fatigued to the point of cracking. The inner and outer conductors can crack under the insulating cable jacket and not be detectable by visual inspection. This will cause intermittent PIM signals to be generated. One way to test for this is to flex or tap on the cable while performing a baseline test. If there are fluctuations in the PIM signal, the cable ~~may~~ can be damaged and should be replaced.

#### 6.5.2 Defining a good low PIM reference load

A good low PIM load can be made using a long section of high quality coaxial cable terminated with a high quality (low PIM) connector. This connector should be soldered to the coaxial cable on both the inner and outer conductors. The length of cable should be held in a fixture so that no fatigue is placed on the connector or cable. When soldering coaxial cables, it should be done very carefully to avoid melting or deforming the insulation, which can cause impedance changes.

### 6.5.3 Test set-up and test site baseline PIM verification

Prior to the testing of the antenna, perform a baseline PIM test set-up noise floor verification. To verify the test set-up itself, a low PIM termination may be used. Check the cables and connections for sensitivity to flexure, mechanical stress and configuration during the baseline test.

The test site should also be evaluated to ensure that it does not generate unacceptable levels of PIM or to identify any potential extraneous interfering RF sources. The test site could be an anechoic test enclosure or a chosen outdoor site. If an anechoic chamber is used, special design considerations are needed as outlined in 6.8. During the site verification, if possible, use a low PIM reference antenna having a radiation pattern and gain comparable to that of the AUT in order to ensure that the test environment is exposed to representative flux densities as for the AUT test.

The actual antenna PIM test should be performed using the same set-up as for the baseline test: minimize movements of components, do not add components, minimize changes in the environment, etc. After the antenna PIM test is completed or as required during the test, compare the baseline test results with previous set-up verification results for any sign of degradation in the test system.

## 6.6 PIM test configurations

A typical test set-up for antenna reverse (reflected) PIM testing is shown in Figure 1 and ~~one~~ another for antenna forward (transmitted) PIM is shown in Figure 2. It should be noted that the dynamic range between the two test configurations should be examined to assess the appropriate choices to use. In both cases, the test should take place in either a well-designed low PIM anechoic chamber or outdoors, which would allow the full range of antenna movement. For the antenna forward (transmitted) PIM test, a low PIM antenna on the receiver side of the test set-up is required. Also, for this test, the environment ~~may~~ can be first verified by using two low PIM antennas.

Whenever possible, the diplexer (Figure 1) and the filter (Figure 2), both of which should be low PIM, shall be placed as close as possible to the AUT input port to minimize PIM generated by the test set-up. The overall cable or waveguide lengths should be minimized to deliver maximum power to the AUT. Also, coaxial and waveguide adapters should be avoided as much as possible.

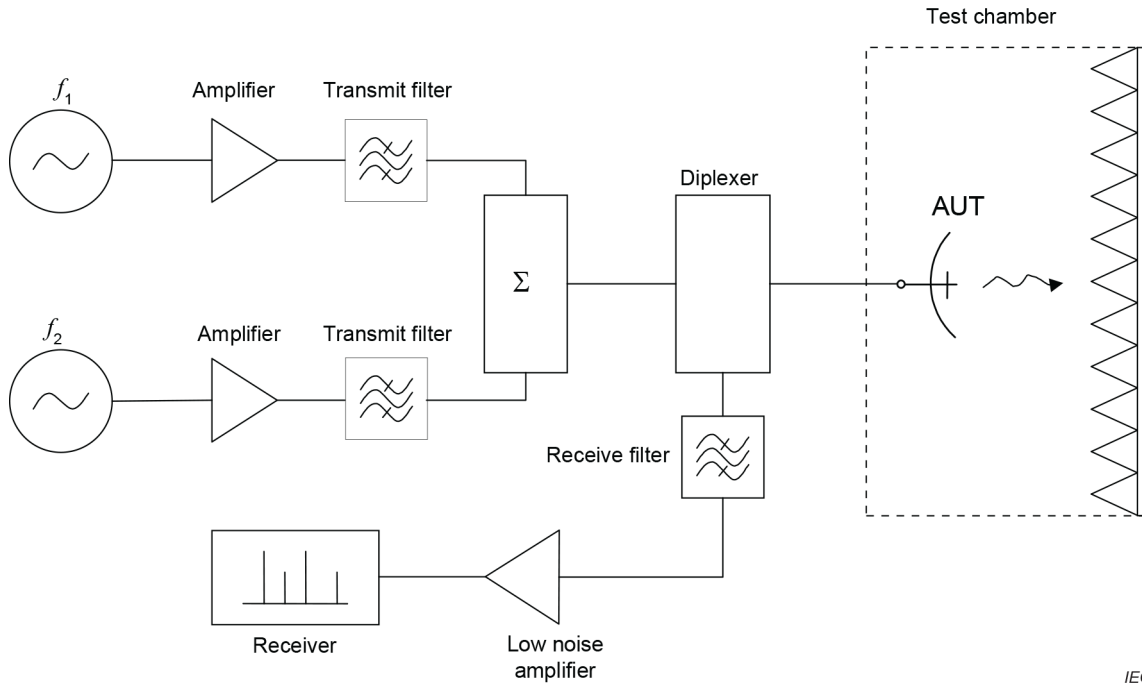

**Figure 1 – Antenna reverse PIM test set-up**

Each set-up has two synthesized sources, amplified separately to avoid AIM (active intermodulation). The two-tone-test results in discrete intermodulation products, whose levels are to be measured. These PIM products are typically first amplified by one or two stages of LNAs before detection by the spectrum analyzer or digital receiver. This is in order to increase the sensitivity of the set-up.

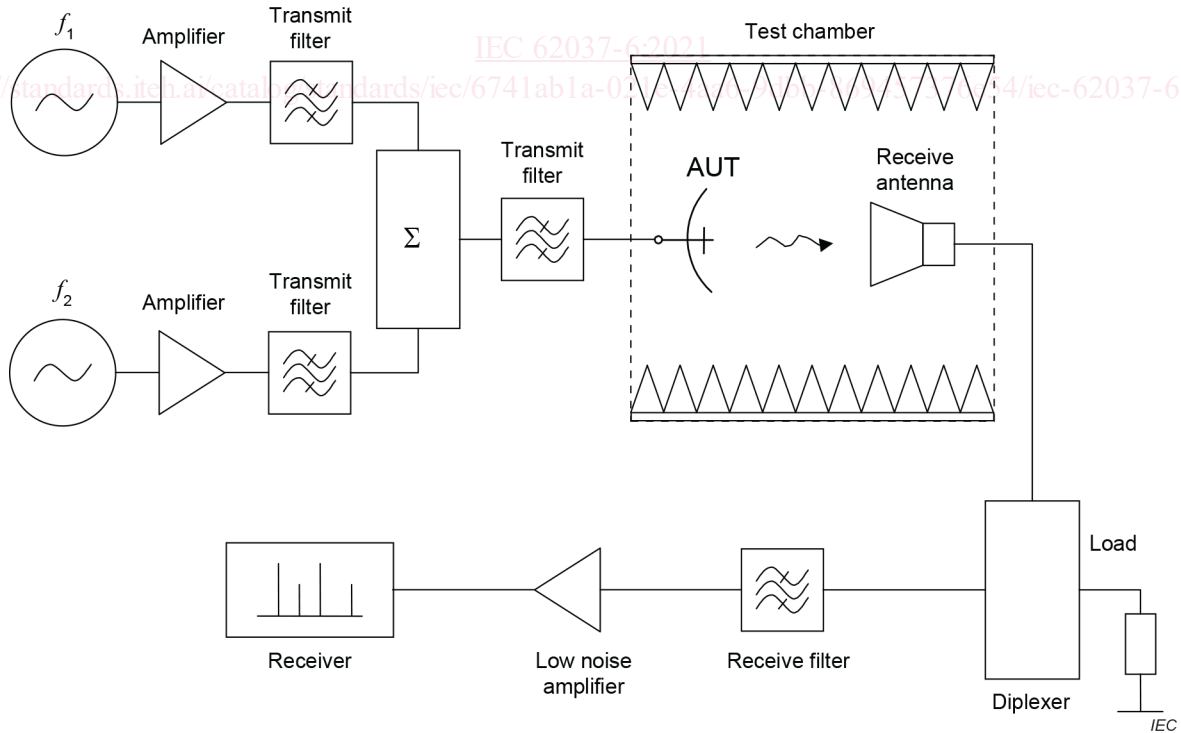

**Figure 2 – Antenna forward PIM test set-up**

## 6.7 Combined environmental and PIM testing

### 6.7.1 General

Whenever possible and practical, each AUT should be measured for PIM while being exposed to representative environmental operating conditions. If it is not possible, the AUT may be measured for PIM before and after exposure to representative environmental conditions.

### 6.7.2 Mechanical considerations

A loose mechanical joint is likely to cause PIM. Materials expand and contract due to temperature changes. Different materials expand and contract at different rates. This difference can cause varying amounts of stress to be induced in any mechanical joint of the antenna components. The differences in expansion and contraction can even cause the parts to move so much as to loosen a mechanical joint. A bolted joint that was torqued to its specified value can loosen to the point where the required clamping force is no longer being produced. Evaluation of mechanical connections may be accomplished by performing PIM testing during thermal cycling.

Vibrations can produce detrimental effects similar to those from thermal environments.

For terrestrial applications, extreme temperature cycling occurs only in specific geographical areas and is more applicable to aeronautical and space applications. Wind-induced vibrations occur in most terrestrial and aeronautical applications but never for space applications. However, vibrations are induced on space-borne antennas during platform manoeuvres. For space and aeronautical applications, it is recommended that PIM testing be performed during thermal cycling before and after vibration testing.

### 6.7.3 Test system cables and connectors

The test cables connected to the antenna under test are exposed to the same test environments as the antenna itself. Therefore, great care shall be taken in selecting cables suitable for PIM testing in the specific test environment. The entire test set-up, including the cables, shall be verified under the same test conditions as for the AUT testing.

## 6.8 PIM test chamber design

### 6.8.1 General

The purpose of 6.8 is to provide guidance for the construction of test chambers suitable for the performance of PIM testing on antennas.

Evaluation of antenna products for PIM presents additional challenges not found with other non-radiating components. The antenna will be connected to an RF source and will radiate RF energy during the PIM test. This energy shall not be allowed to excite potential PIM sources in the test environment. It is also sometimes not practical to perform these tests in an outdoor environment since the radiated RF energy should preferably be contained. To successfully perform PIM testing on antennas, it ~~may~~ can be desirable to construct an RF anechoic chamber specially designed for PIM testing.

The main components of an RF anechoic test chamber are:

- a) RF absorber materials;
- b) supporting structures and walls;
- c) RF shielding.

Each of these components will be discussed in 6.8.2 to 6.8.4.

### 6.8.2 RF absorber materials

RF absorber materials are commonly manufactured from a carbon impregnated foam. This material offers attenuation to radio frequency signals as they pass through it. This attenuation of the signal (absorption of energy) serves in essence as a "load" to the antenna.

RF absorber materials are available in many styles and sizes. The selection of style and size is dependent on the frequency of operation and the placement within the test chamber. Proper selection of the RF absorbers ~~may can~~ be the most critical factor in the construction of a PIM test chamber. Recommendations that ~~may can~~ help in the selection process are as follows:

- a) Select an absorber with an incident RF attenuation greater than 30 dB.
- b) For good results, place pyramidal absorber panels in the field of the antenna radiation pattern, preferably with normal incidence to the beam peak. However, best results can be achieved when the interior of the test chamber is completely covered with RF absorber material.
- c) As a minimum, ensure there are enough panels to avoid back reflections.

For safety purposes, select an absorber that contains fire retardant materials and is rated for the anticipated maximum power dissipation required.

### 6.8.3 Supporting structures and walls

The supporting structure and walls for the PIM test chamber shall provide a suitable inner surface for attachment of the RF absorber material. In some applications, the supporting structure and walls ~~may can~~ also be required to assist in the control of the temperature, the pressure, the humidity level, or other environmental conditions for the test.

The materials and methods of construction will vary greatly depending on the specific application. For many applications, simple lumber and plywood provide very good results. Cement block construction also provides excellent support but at a much greater expense. Some general considerations in designing the support structure and walls are as follows:

- a) The use of metal shielding in the outer structure improves the isolation of the anechoic chamber and is recommended when RF shielding needs to be high (see 6.8.4). However, it is critical to ensure that the design does not include metal-to-metal junctions that themselves have poor PIM performance. Examples of this would include overlapping metal plates or the use of metal hardware going through sheet metal parts that are exposed.
- b) Wood supports can be successfully joined using screws. Screws are stronger than nails and it is easier to control their final location. Do not allow metal fasteners to contact each other, even within the framework.
- c) Make sure that the actual dimensions of absorber panels are known before completing the design of the structure as they do not usually have the exact size advertised.
- d) The size of the test chamber should be large enough to allow the test antenna to be sufficiently far from any RF absorber to avoid mutual coupling between the radiating antenna and the absorber material.
- e) Hinges, fasteners, light fixtures, fire sprinklers, mounting hardware, etc., should all be evaluated for potential PIM generation.

### 6.8.4 RF shielding

RF shielding may or may not be required, depending on the particular application. The purpose of RF shielding ~~may can~~ be for security, to maintain a low RF noise floor in the test facility or ~~may can~~ be required to ensure personnel safety. A method of identifying the need for RF shielding is based on the calculated power densities. From such calculations, it ~~may can~~ be found that RF levels behind the RF absorber are extremely low and therefore safe. It is always recommended that an RF survey of the area surrounding the chamber be performed prior to the approval of the final test plan or procedure.