



Designation: ~~C987 – 10 (Reapproved 2015)~~ C987 – 10 (Reapproved 2019)

Standard Test Method for Vapor Attack on Refractories for Furnace Superstructures¹

This standard is issued under the fixed designation C987; the number immediately following the designation indicates the year of original adoption or, in the case of revision, the year of last revision. A number in parentheses indicates the year of last reapproval. A superscript epsilon (ϵ) indicates an editorial change since the last revision or reapproval.

1. Scope

1.1 This test method covers a procedure for comparing the behavior of refractories in contact with vapors under conditions intended to simulate the environment within a ~~glass-melting-glass-melting~~ or other type of furnace when refractories are exposed to vapors from raw batch, molten glass, fuel, fuel contaminants, or other sources. This procedure is intended to accelerate service conditions for the purpose of determining in a relatively short time the interval resistance to fluxing, bloating, shrinkage, expansion, mineral conversion, disintegration, or other physical changes that may occur.

1.2 The values stated in SI units are to be regarded as standard. No other units of measurement are included in this standard.

1.3 *This standard does not purport to address all of the safety concerns, if any, associated with its use. It is the responsibility of the user of this standard to establish appropriate ~~safety~~ safety, health, and ~~health~~ environmental practices and determine the applicability of regulatory limitations prior to use.*

1.4 *This international standard was developed in accordance with internationally recognized principles on standardization established in the Decision on Principles for the Development of International Standards, Guides and Recommendations issued by the World Trade Organization Technical Barriers to Trade (TBT) Committee.*

2. Significance and Use

2.1 This test method provides a guide for evaluating the resistance of refractories in ~~glass-melting-glass-melting~~ furnace superstructures to vapor attack. This test method may also be useful for evaluating refractories in other applications where vapor attack occurs.

2.2 An electric-heated furnace is recommended. Water vapor and other atmospheric components in a gas- or fuel-fired furnace may participate in the chemical and physical reactions being studied. Results may differ, therefore, depending upon the nature and type of firing employed.

2.3 The degree of correlation between this test method and service performance is not fully determinable. This is intended to be an accelerated test method that generates a substantial degree of reaction in a relatively short amount of time. This acceleration may be accomplished by changing the composition and/or concentration of the reactants, increasing temperatures, or by performing the test in an isothermal environment.

2.4 Since the test method may not accurately simulate the service environment, observed results of this test method may not be representative of those found in service. It is imperative that the user understand and consider how the results of this test method may differ from those encountered in service. This is particularly likely if the reaction products, their nature, or their degree differ from those normally found in the actual service environment.

2.5 It is incumbent upon the user to understand that this is an aggressive, accelerated test method and to be careful in interpreting the results. If, for example, the reaction species have never been found in a ~~real-world-real-world~~ furnace, then this test method should not necessarily be considered valid to evaluate the refractory in question.

3. Apparatus

3.1 The crucible for containing the reactant shall be a dense alumina or platinum crucible of conical shape with dimensions of 43 mm in diameter at top, 33 mm in diameter at bottom, and 53 mm high.

3.2 The crucible-cover assembly (Fig. 1) may be supported within a suitable refractory holding crucible (Fig. 2) such as mullite to maintain the position of the cover, if an excessive amount of glass phase reaction product is anticipated.

¹ This test method is under the jurisdiction of ASTM Committee C08 on Refractories and is the direct responsibility of Subcommittee C08.10 on Refractories for Glass. Current edition approved Oct. 1, 2015/Sept. 1, 2019. Published October 2015/September 2019. Originally approved in 1983. Last previous edition approved in 2010/2015 as ~~C987 – 10~~ C987 – 10 (2015). DOI: 10.1520/C0987-10R15.10.1520/C0987-10R19.

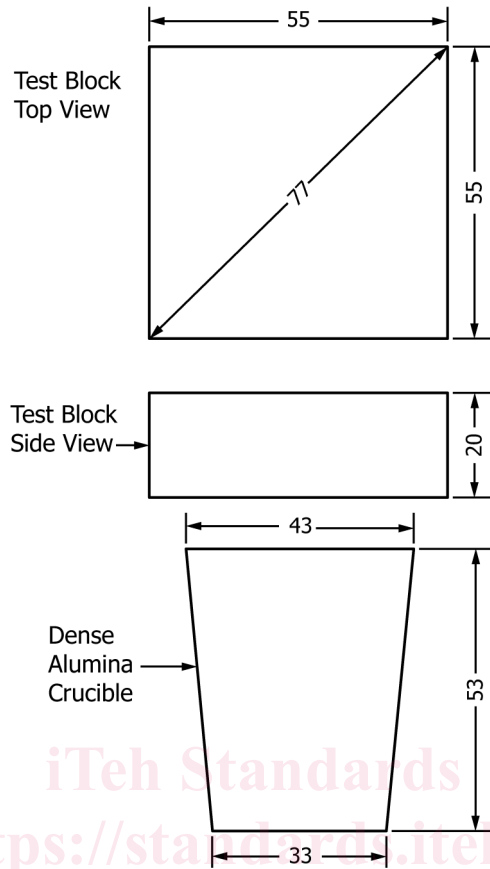

FIG. 1 Crucible-Cover Assembly

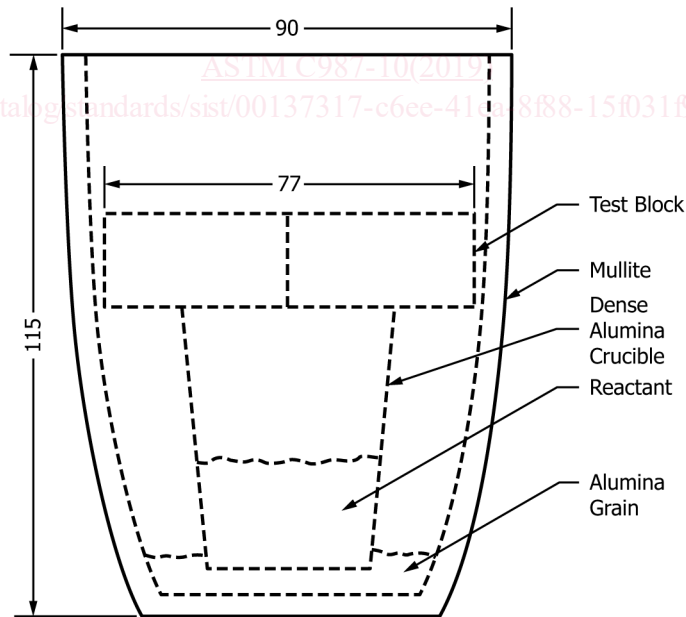

FIG. 2 Refractory Holding Crucible

3.3 The electric heating chamber shall be of sufficient size to accommodate at least three assemblies for comparative evaluation. The temperature control system shall be capable of maintaining a desired holding temperature with a tolerance of $\pm 3^{\circ}\text{C}$; $\pm 3^{\circ}\text{C}$.