International Standard



4510/2

INTERNATIONAL ORGANIZATION FOR STANDARDIZATION • МЕЖДУНАРОДНАЯ ОРГАНИЗАЦИЯ ПО СТАНДАРТИЗАЦИИ • ORGANISATION INTERNATIONALE DE NORMALISATION

**Earth-moving machinery — Service tools —
Part 2: Common repair tools — Mechanical pullers and
pushers**

*Engins de terrassement — Outils d'entretien et de dépannage — Partie 2: Outils de réparation courants — Extracteurs
mécaniques par traction et par pression*

ITeH STANDARD PREVIEW

First edition — 1986-06-15

(standards.iteh.ai)

[ISO 4510-2:1986](https://standards.iteh.ai/catalog/standards/sist/ee017a21-6a3c-483c-938f-1ef006a24d1/iso-4510-2-1986)

<https://standards.iteh.ai/catalog/standards/sist/ee017a21-6a3c-483c-938f-1ef006a24d1/iso-4510-2-1986>

UDC 621.883 : 621.878 / .879

Ref. No. ISO 4510/2-1986 (E)

Descriptors : earth-moving equipment, repairs, tools, hand tools, assembly tools, nomenclature.

Price based on 7 pages

Foreword

ISO (the International Organization for Standardization) is a worldwide federation of national standards bodies (ISO member bodies). The work of preparing International Standards is normally carried out through ISO technical committees. Each member body interested in a subject for which a technical committee has been established has the right to be represented on that committee. International organizations, governmental and non-governmental, in liaison with ISO, also take part in the work.

Draft International Standards adopted by the technical committees are circulated to the member bodies for approval before their acceptance as International Standards by the ISO Council. They are approved in accordance with ISO procedures requiring at least 75 % approval by the member bodies voting.

International Standard ISO 4510/2 was prepared by Technical Committee ISO/TC 127, *Earth-moving machinery*.

Users should note that all International Standards undergo revision from time to time and that any reference made herein to any other International Standard implies its latest edition, unless otherwise stated.

STANDARD PREVIEW
(standards.iteh.ai)

1efid006a24d1/iso-4510-2-1986

Earth-moving machinery — Service tools — Part 2: Common repair tools — Mechanical pullers and pushers

1 Scope and field of application

This part of ISO 4510 lays down, for guidance, the types, general requirements and main nominal dimensions of mechanical pullers, attachments and adaptors used for carrying out repair work.

This part of ISO 4510 deals with mechanical pullers and push pullers, pulling attachments and adaptors which are commonly used for pulling gears and bearings mounted on earth-moving machinery, as defined in ISO 6165.

Machine manufacturers should choose suitable dimensions for machine design from the tables accompanying figures 5, 6, 7 and 8, and specify, in suitable manuals as described in ISO 6750, the type of tools to be used for carrying out repair work.

2 References

ISO 4510/1, *Earth-moving machinery — Service tools — Part 1: Common maintenance and adjustment tools.*

ISO 6165, *Earth-moving machinery — Basic types — Vocabulary.*

ISO 6750, *Earth-moving machinery — Operation and maintenance — Format and content of manuals.*

3 Types of pullers, attachments and adaptors

3.1 Pullers, mechanical, gear and bearing, external (see figure 1)

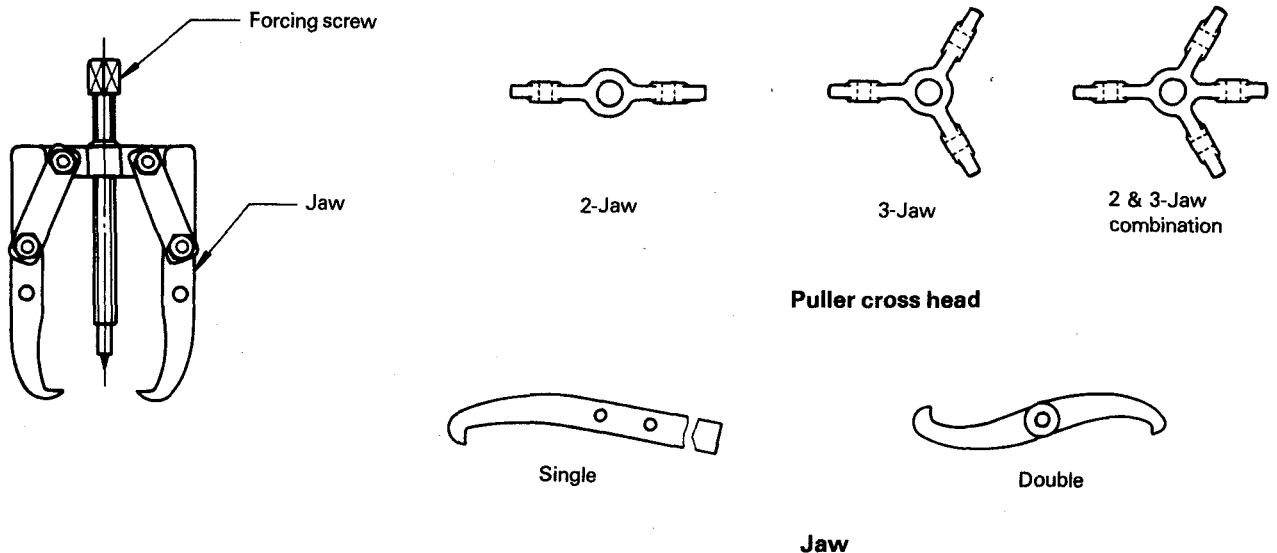

Figure 1

3.2 Push pullers, mechanical, gear and bearing
(see figure 2)

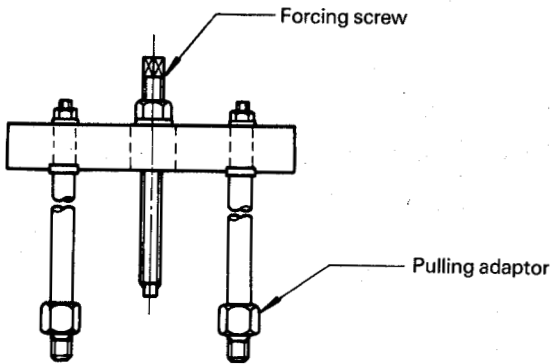
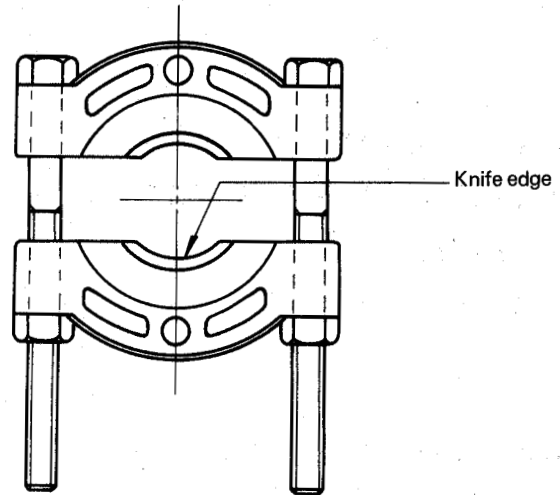

Figure 2



External

3.3 Pulling attachments, mechanical, gear and bearing [see figures 3 a) and 3b)]

ITIH STANDARD PREVIEW
(standards.iteh.ai)

Figure 3 b)

3.4 Pulling adaptor, mechanical, male and female thread (see figure 4 and also figure 2)

ISO 4510/2-1986

<https://standards.iteh.ai/catalog/standards/sist/ee017a21-6a3c-483c-938f-1ef006a24d1/iso-4510-2-1986>

1ef006a24d1/iso-4510-2-1986

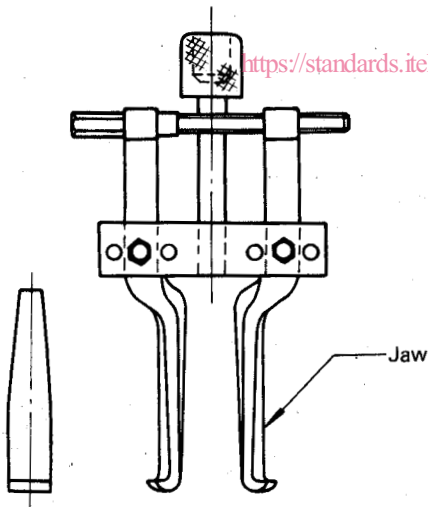

Internal

Figure 3 a)

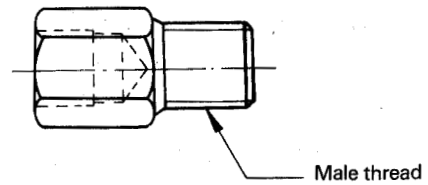

Figure 4

4 General requirements

4.1 The pullers and/or attachments shall be designed to allow free movement with a minimum of clearance between the parts.

4.2 The head of the forcing screw and/or its nuts tightened during repair work shall be either square or hexagonal in shape and of a size suitable for accepting a standard size wrench, as specified in ISO 4510/1.

4.3 The pressure end of the forcing screw shall have a 60° conical point to ensure that loads are applied in the shaft centre.

4.4 The gripping ends of the jaws shall be designed and manufactured to prevent slippage from the gear or bearing being pulled at any setting within the capacity of the pullers.

4.5 Internal and external pulling attachments shall be suitable for use with push pullers and pullers, respectively, when required.

4.6 Pulling adaptors shall be designed for use with push pullers, where applicable.

5 Dimensions

The illustrations in figures 5, 6 and 7 are for the convenience of identification and are not intended to specify the structure (shape, configuration, etc.) of pullers and associated attachments.

NOTE — Inch dimensions are not specified in this part of ISO 4510: inch dimensions equivalent to the metric dimensions given may only be used when there is a need to reflect local conditions.

5.1 Jaw tip of pullers (see figure 5)

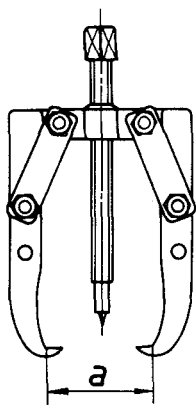

Types No. 1 and No. 2

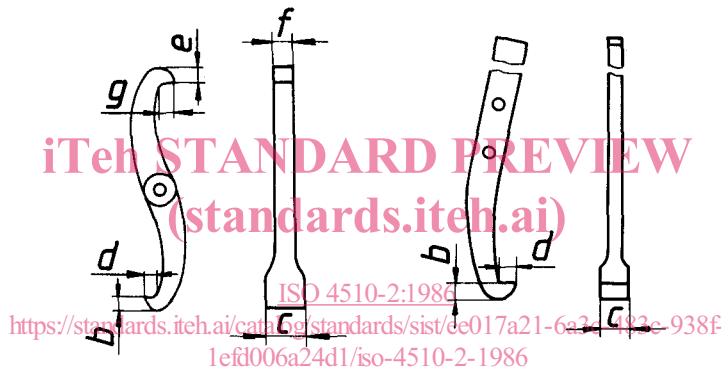

Type No. 3

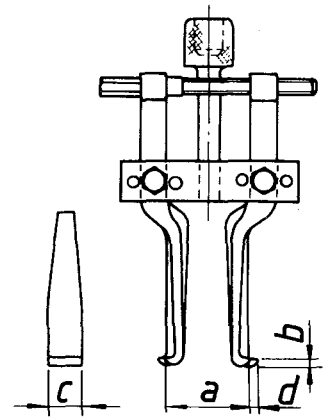

Types No. 4 and No. 5

Dimensions in millimetres

Type No.	a	b	c	d	e	f	g
1	80 max.	6,5	17,5	6,0	9,5	9,0	6,5
2	125 max.	9,5	24,0	8,0	7,5	26,0	11,5
3	280 max.	14,5	26,0	14,5	—	—	—
4	40 to 150	3,5	29,0	6,5	—	—	—
5	75 to 225	6,5	51,0	6,5	—	—	—

Figure 5

5.2 Push puller (see figure 6)

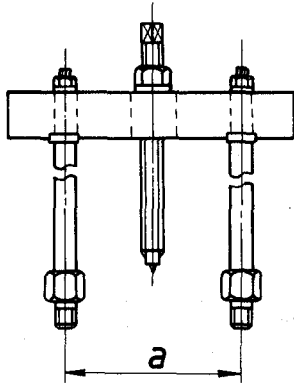

Dimensions in millimetres

Type No.	<i>a</i>
1	90 to 300
2	180 to 420

Figure 6

5.3 Knife edge of pulling attachment (see figure 7)

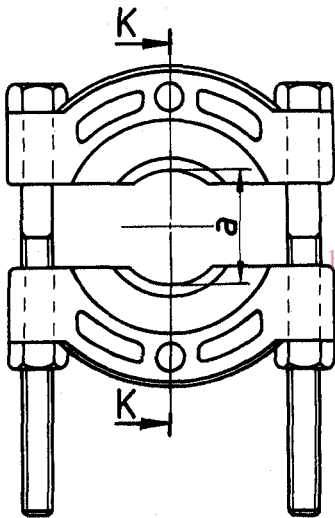

iTeh STANDARD PREVIEW
(standards.iteh.ai)

Dimensions in millimetres

Type No.	<i>a</i>	<i>b</i>	<i>c</i>	<i>d</i>
1	5 to 50	2,0	3,0	4,5
2	10 to 110	5,0	9,0	7,5
3	15 to 135	6,5	13,0	11,0
4	15 to 205	7,5	18,5	12,0
5	20 to 340	9,5	20,0	23,0



K-K

Figure 7

5.4 Male thread of pulling adaptor (see figure 8)

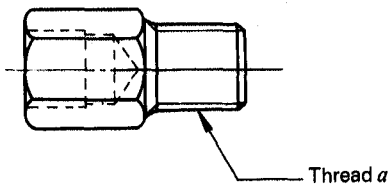

Dimensions in millimetres

Type No.	Thread <i>a</i>
1	M12 × 1,5
2	M12 × 1,75
3	M14 × 1,5
4	M14 × 2,0
5	M16 × 1,5
6	M16 × 2,0
7	M18 × 2,5
8	M20 × 2,5

Figure 8

Annex

Examples of the application of mechanical pullers and their attachments

A.1 Puller (see figure 9)

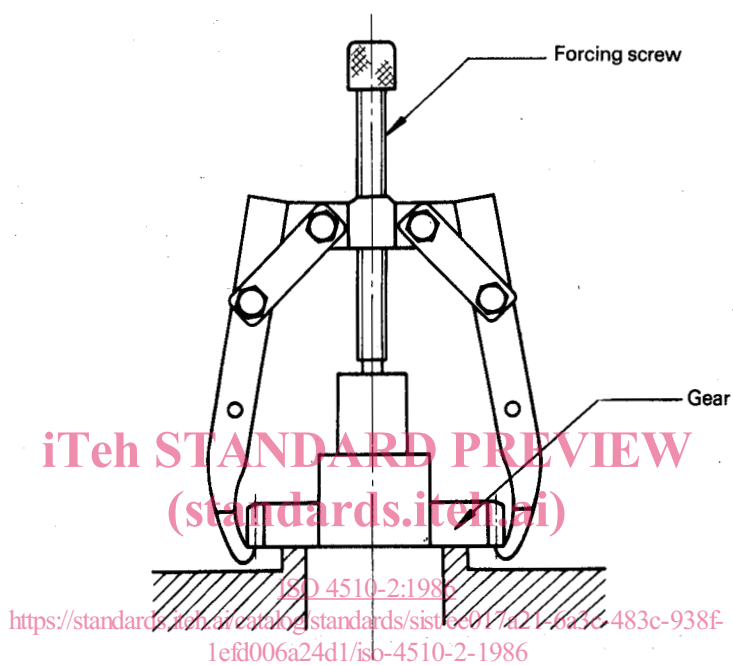

Figure 9

A.2 Push puller with adaptor (see figure 10)

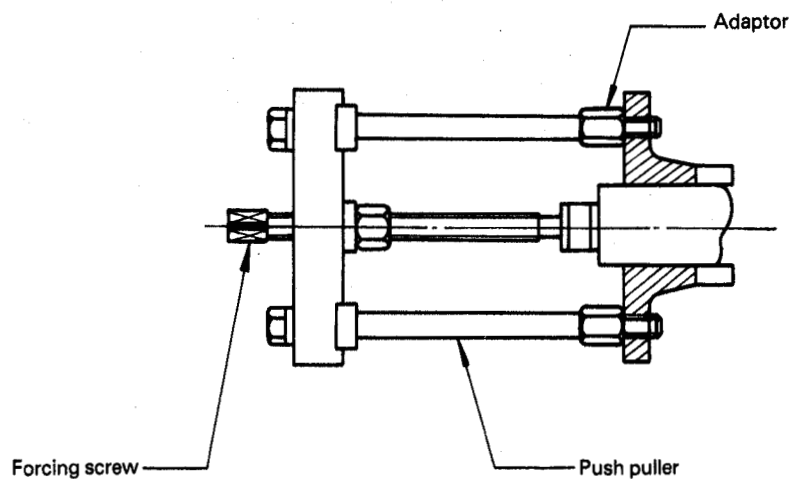
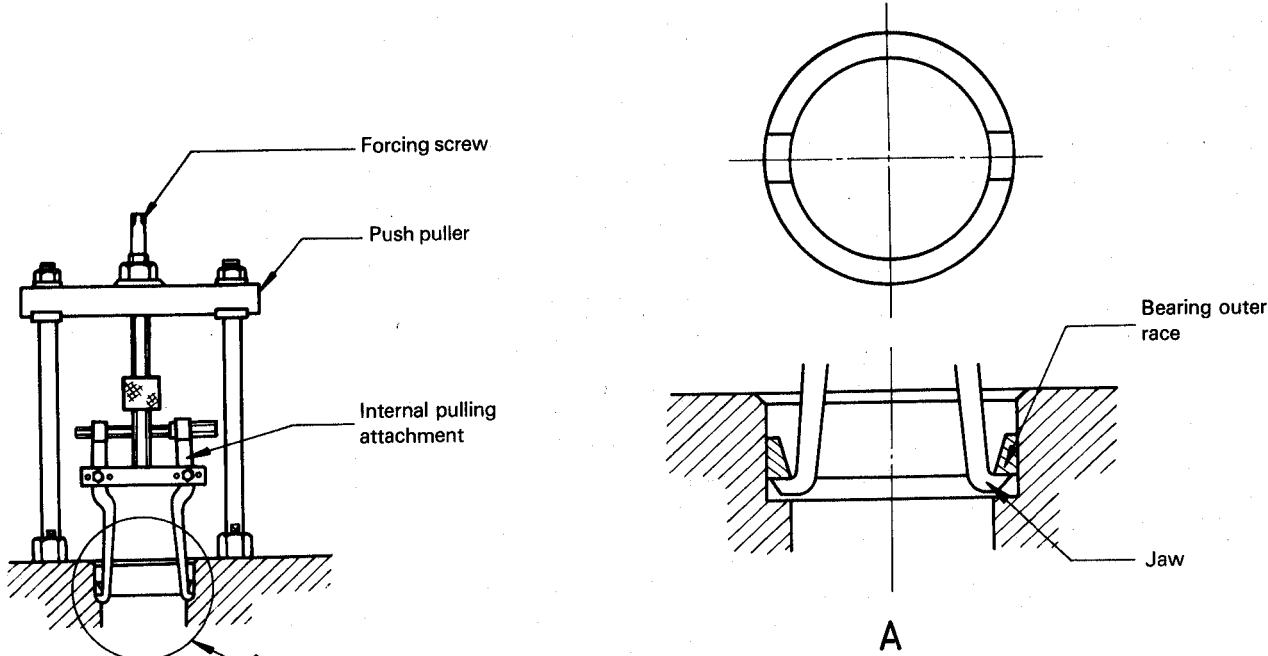

Figure 10

A.3 Push puller with internal pulling attachment (see figure 11)



iTeh STANDARD PREVIEW
(standards.iteh.ai)

Figure 11
ISO 4510-2:1986

<https://standards.iteh.ai/catalog/standards/sist/ee017a21-6a3c-483c-938f-fcd006a24d17/iso-4510-2-1986>

A.4 Push puller with external pulling attachment (see figure 12)

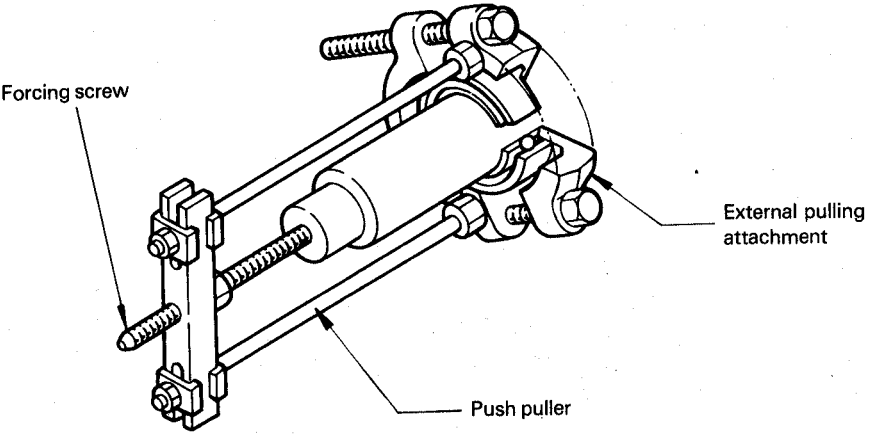
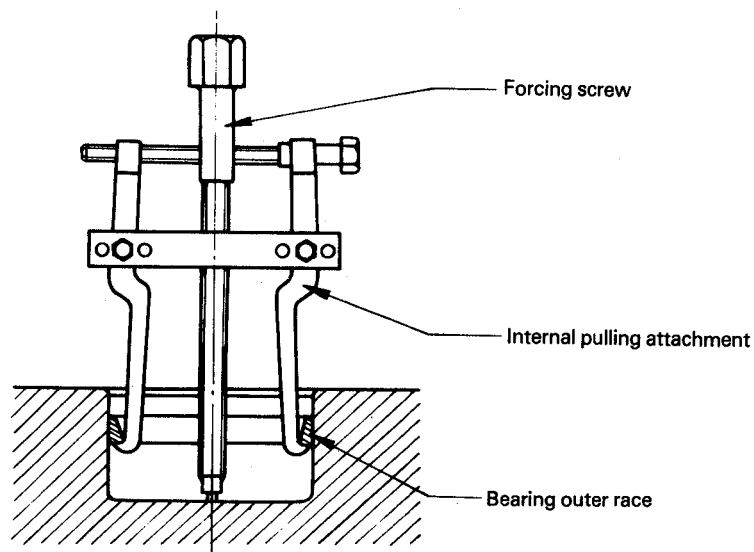

Figure 12

A.5 Internal pulling attachment with forcing screw (see figure 13)



iTeh STANDARD PREVIEW
 Figure 13
(standards.iteh.ai)

ISO 4510-2:1986

<https://standards.iteh.ai/catalog/standards/sist/ee017a21-6a3c-483c-938f-1efd006a24d1/iso-4510-2-1986>