



Designation: ~~C273/C273M – 18~~ C273/C273M – 19

Standard Test Method for Shear Properties of Sandwich Core Materials¹

This standard is issued under the fixed designation C273/C273M; the number immediately following the designation indicates the year of original adoption or, in the case of revision, the year of last revision. A number in parentheses indicates the year of last reapproval. A superscript epsilon (ϵ) indicates an editorial change since the last revision or reapproval.

This standard has been approved for use by agencies of the U.S. Department of Defense.

1. Scope

1.1 This test method covers the determination of shear properties of sandwich construction core materials associated with shear distortion of planes parallel to the facings. It covers the determination of shear strength parallel to the plane of the sandwich, and the shear modulus associated with strains in a plane normal to the facings. The test may be conducted on core materials bonded directly to the loading plates or the sandwich facings bonded to the plates. Permissible core material forms include those with continuous bonding surfaces (such as balsa wood and foams) as well as those with discontinuous bonding surfaces (such as honeycomb).

1.2 The values stated in either SI units or inch-pound units are to be regarded separately as standard. The values stated in each system ~~may~~ are not necessarily exact equivalents; therefore, to ensure conformance with the standard, each system shall be used independently of the other. ~~Combining other, and~~ values from the two systems ~~may result in non-conformance with the standard; shall not be combined.~~

1.2.1 Within the text, the inch-pound units are shown in brackets.

1.3 *This standard does not purport to address all of the safety concerns, if any, associated with its use. It is the responsibility of the user of this standard to establish appropriate safety, health, and environmental practices and determine the applicability of regulatory limitations prior to use.*

1.4 *This international standard was developed in accordance with internationally recognized principles on standardization established in the Decision on Principles for the Development of International Standards, Guides and Recommendations issued by the World Trade Organization Technical Barriers to Trade (TBT) Committee.*

2. Referenced Documents

2.1 ASTM Standards:²

[C271/C271M Test Method for Density of Sandwich Core Materials](#)

[C393 Test Method for Core Shear Properties of Sandwich Constructions by Beam Flexure](#)

[D792 Test Methods for Density and Specific Gravity \(Relative Density\) of Plastics by Displacement](#)

[D883 Terminology Relating to Plastics](#)

[D2584 Test Method for Ignition Loss of Cured Reinforced Resins](#)

[D2734 Test Methods for Void Content of Reinforced Plastics](#)

[D3171 Test Methods for Constituent Content of Composite Materials](#)

[D3878 Terminology for Composite Materials](#)

[D5229/D5229M Test Method for Moisture Absorption Properties and Equilibrium Conditioning of Polymer Matrix Composite Materials](#)

[D5687/D5687M Guide for Preparation of Flat Composite Panels with Processing Guidelines for Specimen Preparation](#)

[D5961/D5961M Test Method for Bearing Response of Polymer Matrix Composite Laminates](#)

[E4 Practices for Force Verification of Testing Machines](#)

[E6 Terminology Relating to Methods of Mechanical Testing](#)

¹ This test method is under the jurisdiction of ASTM Committee D30 on Composite Materials and is the direct responsibility of Subcommittee D30.09 on Sandwich Construction.

Current edition approved Nov. 1, 2018/Sept. 1, 2019. Published December 2018/September 2019. Originally approved in 1951. Last previous edition approved in 2016/2018 as ~~C273 – 16~~ C273/C273M – 18. DOI: ~~10.1520/C0273_C0273M-18~~ 10.1520/C0273_C0273M-19.

² For referenced ASTM standards, visit the ASTM website, www.astm.org, or contact ASTM Customer Service at service@astm.org. For *Annual Book of ASTM Standards* volume information, refer to the standard's Document Summary page on the ASTM website.

[E122 Practice for Calculating Sample Size to Estimate, With Specified Precision, the Average for a Characteristic of a Lot or Process](#)

[E177 Practice for Use of the Terms Precision and Bias in ASTM Test Methods](#)

[E456 Terminology Relating to Quality and Statistics](#)

3. Terminology

3.1 *Definitions*—Terminology [D3878](#) defines terms relating to high-modulus fibers and their composites, as well as terms relating to sandwich constructions. Terminology [D883](#) defines terms relating to plastics. Terminology [E6](#) defines terms relating to mechanical testing. Terminology [E456](#) and Practice [E177](#) define terms relating to statistics. In the event of a conflict between terms, Terminology [D3878](#) shall have precedence over the other terminologies.

3.2 Symbols:

γ	= core engineering shear strain
τ	= core shear stress
b	= width of specimen
c	= thickness of the core
CV	= coefficient of variation statistic of a sample population for a given property (in percent)
d	= overall specimen thickness
G	= core shear modulus
L	= length of specimen
L'	= <u>length of fixture overhang</u>
P	= force on specimen
S	= $\Delta P / \Delta u$, slope of initial portion of force-deflection curve
S_{n-1}	= standard deviation statistic of a sample population for a given property
t_1	= first facesheet thickness (measured or nominal)
t_2	= second facesheet thickness (measured or nominal)
u	= displacement of loading plates
X	= <u>fixture line of loading offset distance</u>
\bar{x}	= mean or average (estimate of mean) of a sample population for a given property
x_1	= test result for an individual specimen from the sample population for a given property

4. Summary of Test Method

4.1 This test method consists of subjecting a sandwich core or sandwich panel to monotonically increasing shear force parallel to the plane of its faces. The force is transmitted to the specimen through bonded loading plates that are subjected to opposing tensile or compressive displacements that result in a shear force on the sandwich core. Core shear modulus, stress, and strength are reported in terms of the nominal shear area of the core.

4.2 The only acceptable failure mode is shear failure of the core material. Adhesive or cohesive failures, or both, at the core-to-facesheet, facesheet-to-load-plate, or (if no facesheets are used) core-to-load-plate interface are not acceptable failure modes.

5. Significance and Use

5.1 The core shear properties are fundamental properties that are used in the design of sandwich panels. This test method provides information on the force-deflection behavior of sandwich constructions or cores when loaded in shear parallel to the plane of the facings. From a complete force-deflection curve, it is possible to compute core shear stress at any force (such as the shear stress at proportional limit, at yield, or at maximum force) and to compute an effective core shear modulus.

5.2 The test does not produce pure shear, but the specimen length is prescribed so that secondary stresses have a minimum effect. Approximate shear properties can also be obtained from a sandwich flexure test (see Test Method [C393](#)).

5.3 This test method provides a standard method of obtaining sandwich core shear data for material specifications, sandwich panel design, research and development applications, and quality assurance.

5.4 Factors that influence core shear strength and shall therefore be reported include the following: facing material, core material, adhesive material, methods of material fabrication, core geometry (density, cell size, orientation, and so forth), adhesive thickness, specimen geometry and associated measurement accuracy, specimen preparation, specimen conditioning, environment of testing, specimen alignment, loading procedure, speed of testing, and adhesive void content. Further, core-to-facing strength may be different between precured/bonded and co-cured facings in sandwich panels with the same core and facing material.

6. Interferences

6.1 *Material and Specimen Preparation*—Poor material fabrication practices, lack of control of fiber alignment, and damage induced by improper specimen machining are known causes of high data scatter in composites in general. Specific material factors

that affect sandwich composites include variability in core density and degree of cure of resin in both facing matrix material and core bonding adhesive. Important aspects of sandwich panel specimen preparation that contribute to data scatter are incomplete or nonuniform core bonding to ~~facings, facings~~; misalignment of core and facing ~~elements, elements~~; the existence of joints, voids, or other core and facing ~~discontinuities, discontinuities~~; out-of-plane ~~curvature, curvature~~; facing thickness ~~variation, variation~~; and surface roughness. For this particular core shear test, thickness of the adhesive bond to honeycomb core (adhesive-filled depth into the honeycomb core cells) may affect the core shear strength and modulus values depending on the core thickness.

6.2 *System Alignment*—Unintended loading eccentricities will cause premature failure. Every effort should be made to eliminate undesirable eccentricities from the test system. Such eccentricities may occur as a result of misaligned grips, poor specimen preparation, or poor alignment of the bonded loading plates.

6.3 *Geometry*—Specific geometric factors that affect core shear behavior of sandwich panels ~~includes~~include core cell geometry (shape, density, orientation), core thickness, and adhesive thickness.

6.4 *Environment*—Results are affected by the environmental conditions under which the tests are conducted. Specimens tested in various environments can exhibit significant differences in both static strength and failure mode. Critical environments must be assessed independently for each sandwich construction tested.

6.5 *Loading Direction*—FEA analysis of the Test Method C273/C273M test configurations shows that both compressive and tensile normal stress concentrations occur at the ends of the core surfaces; the highest stress concentration is of the same sense as the loading mode (that is, the tension loading mode produces higher through-thickness tensile stress concentrations than the compression loading mode). Core shear strengths tend to be more influenced by tensile normal stress concentrations than compressive normal stresses. The result is, for some cores, the core shear strength using the Test Method C273/C273M compression loading mode agrees well with strength results from the Test Method C393 short beam bending test method, whereas the Test Method C273/C273M tension loading mode can produce a lower strength result.

7. Apparatus

7.1 *Micrometers and Calipers*—A micrometer with a 4 to 7 mm [0.16 to 0.28 in.] nominal diameter ball-interface or a flat anvil interface shall be used to measure the specimen thickness. A ball interface is recommended for thickness measurements when facings are bonded to the core and at least one surface is irregular (for example, the bag-side of a thin facing laminate that is neither smooth nor flat). A micrometer or caliper with a flat anvil interface is recommended for thickness measurements when facings are bonded to the core and both surfaces are smooth (for example, tooled surfaces). A micrometer or caliper with a flat anvil interface shall be used for measuring length and width, as well as the specimen thickness when no facings are present. The use of alternative measurement devices is permitted if specified (or agreed to) by the test requestor and reported by the testing laboratory. The accuracy of the instruments shall be suitable for reading to within 1 % of the sample dimensions. For typical specimen geometries, an instrument with an accuracy of ± 0.025 mm [± 0.001 in.] is adequate for the length, width, and thickness measurements.

7.2 *Test Fixtures*—Either a tensile or compressive loading mode may be used. In either case, the test specimen shall be rigidly supported by means of steel plates bonded to the facings (see Note 1) as shown in Fig. 1. The thickness of the plates may be varied in accordance with the strength of the sandwich (see Note 2), but the plate length shall be such that the line of action of the direct tensile or compressive force shall pass through the diagonally opposite corners of the sandwich as shown in Fig. 1, and as calculated per Fig. 2. A correct line of load action may also be obtained by modifying the core length to thickness ratio provided the specimen dimensional requirements noted in 8.2 are fulfilled.

NOTE 1—To ensure a core shear failure on some honeycomb cores, two plies of adhesive must be used to bond the honeycomb to the steel plates. This provides deeper adhesive fillets on the honeycomb cell walls.

NOTE 2—It has been found that loading plates having a bending stiffness per unit width, $D = EI / b$, not less than 2.67 MN · mm²/mm width per millimeter of core thickness (600 000 lb·in.²/in. per inch of core thickness) have performed satisfactorily.

7.2.1 *Tension Loading*—Either pinned or bolted load plate-to-universal-joint test fixtures, as shown in Fig. 23, may be used. The overall load-train shall be of the suspended, self-aligning type.

7.2.2 *Compression Loading*—Load plates shall taper to a knife-edge and fit into V-notch loading blocks, as shown in Fig. 34. V-notch loading blocks shall be rigidly attached to the test machine and aligned flat and parallel to within ± 0.02 mm [± 0.001 in.].

7.3 *Testing Machine*—The testing machine shall be in accordance with Practices E4 and shall satisfy the following requirements:

7.3.1 *Testing Machine Configuration*—The testing machine shall have both an essentially stationary head and a movable head.

7.3.2 *Drive Mechanism*—The testing machine drive mechanism shall be capable of imparting to the movable head a controlled velocity with respect to the stationary head. The velocity of the movable head shall be capable of being regulated in accordance with 11.7.

7.3.3 *Force Indicator*—The testing machine force-sensing device shall be capable of indicating the total force being carried by the test specimen. This device shall be essentially free from inertia lag at the specified rate of testing and shall indicate the force with an accuracy over the force range(s) of interest of within ± 1 % of the indicated value.

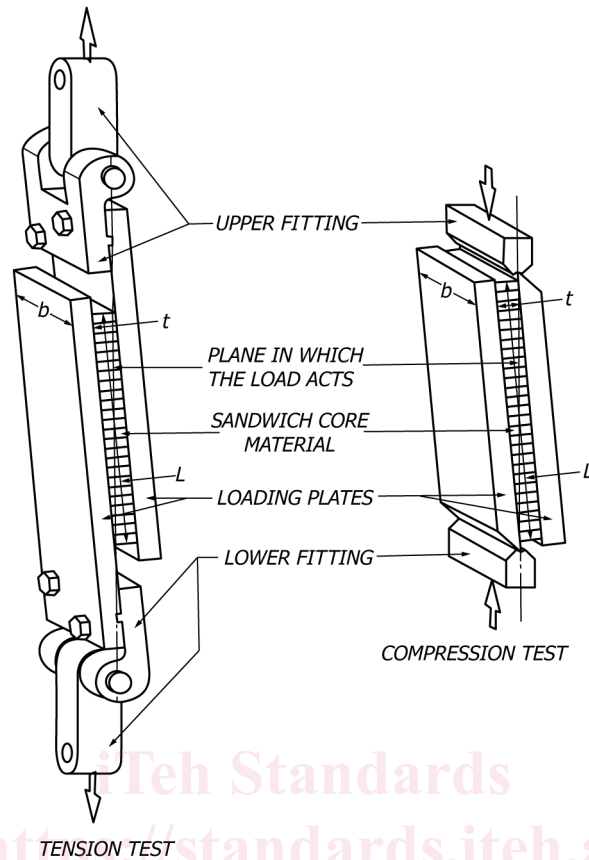

FIG. 1 Plate Shear Specimens, Force Line of Action

7.3.4 *Deflectometer, Compressometer, or Extensometer*—The deflection measurement device shall be capable of measuring the displacement with a precision of at least $\pm 1\%$. [ASTM C273/C273M-19](http://standards.iteh.ai/ASTM-C273/C273M-19)

7.4 *Conditioning Chamber*—When conditioning materials at non-laboratory environments, a temperature/vapor-level controlled environmental conditioning chamber is required that shall be capable of maintaining the required temperature to within $\pm 3^\circ\text{C}$ [$\pm 5^\circ\text{F}$] $\pm 3^\circ\text{C}$ [$\pm 5^\circ\text{F}$] and the required relative humidity level to within $\pm 3\%$. Chamber conditions shall be monitored either on an automated continuous basis or on a manual basis at regular intervals.

7.5 *Environmental Test Chamber*—An environmental test chamber is required for test environments other than ambient testing laboratory conditions. This chamber shall be capable of maintaining the entire test specimen at the required test environment during the mechanical test.

8. Sampling and Test Specimens

8.1 *Sampling*—Test at least five specimens per test condition unless valid results can be gained through the use of fewer specimens, as in the case of a designed experiment. For statistically significant data, consult the procedures outlined in Practice E122. Report the method of sampling.

8.2 *Geometry*—The test specimens shall have a thickness equal to the thickness of the sandwich, a width not less than 50 mm [2.0 in.], and a length not less than twelve times the thickness.

8.3 *Facesheet Thickness*—Accurate measurement of facesheet thicknesses is difficult after secondary bonding or co-curing/co-bonding of the facesheets and core. ~~The~~ ~~If~~ ~~direct~~ ~~measurement~~ ~~of~~ ~~the~~ ~~facesheets~~ ~~is~~ ~~not~~ ~~feasible~~, the test requestor is responsible for specifying the facesheet thicknesses to be used for the calculations in this test method, ~~if~~ ~~direct~~ ~~measurement~~ ~~of~~ ~~the~~ ~~facesheets~~ ~~is~~ ~~not~~ ~~feasible~~. ~~method~~. For metallic or precured composite facesheets which are secondarily bonded to the core, the facesheet thickness should be measured prior to bonding. In these cases, the test requestor may specify that either or both measured and nominal thicknesses be used in the calculations. For ~~co-cured~~ ~~co-bonded~~ composite facesheets, the thicknesses are generally calculated using nominal per ply thickness values.

8.4 *Specimen Preparation and Machining*—Guide D5687/D5687M provides recommended specimen preparation practices and should be followed where practical.

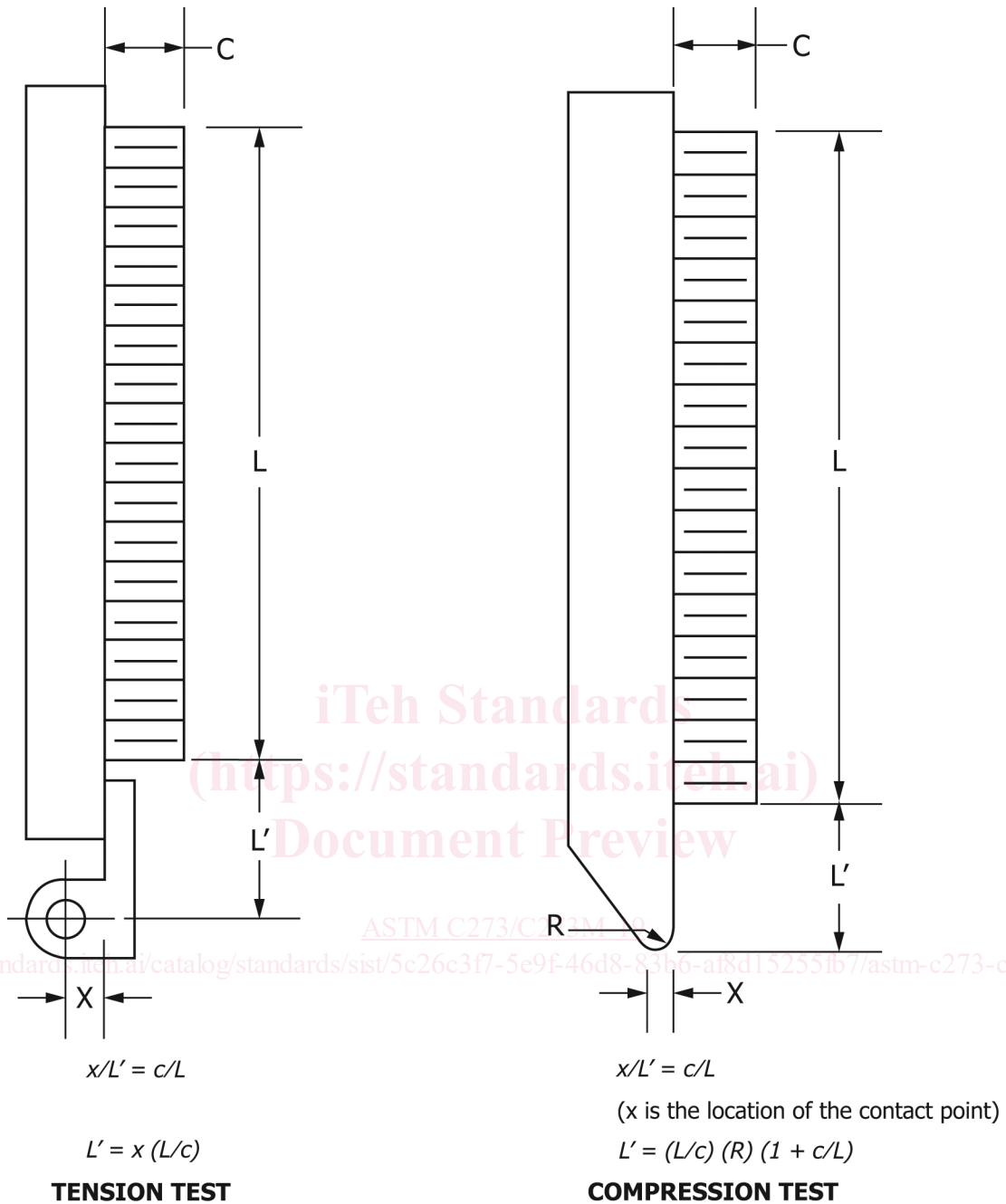

FIG. 2 Plate Shear Specimens, Fixture Length Calculations

8.5 *Labeling*—Label the test specimens so that they will be distinct from each other and traceable back to the panel of origin, and will neither influence the test nor be affected by it.

9. Calibration

9.1 The accuracy of all measuring equipment shall have certified calibrations that are current at the time of use of the equipment.

10. Conditioning

10.1 The recommended pre-test specimen condition is effective moisture equilibrium at a specific relative humidity as established by Test Method **D5229/D5229M**; however, if the test requester does not explicitly specify a pre-test conditioning environment, conditioning is not required and the test specimens may be tested as prepared.

NOTE 3—The term *moisture*, as used in Test Method **D5229/D5229M**, includes not only the vapor of a liquid and its condensate, but the liquid itself in large quantities, as for immersion.

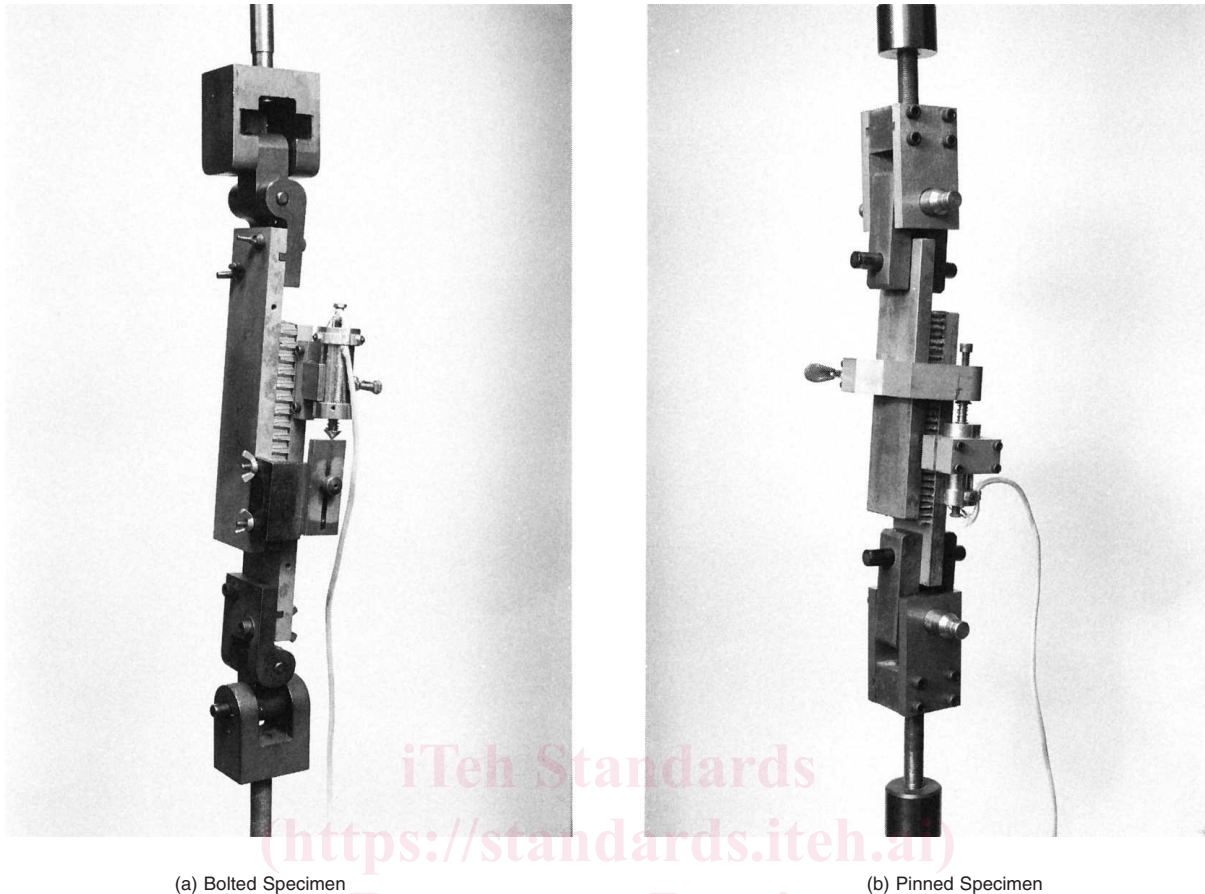

(a) Bolted Specimen

(b) Pinned Specimen

FIG. 23 Tensile Plate Shear Test Set Up

10.2 The pre-test specimen conditioning process, to include specified environmental exposure levels and resulting moisture content, shall be reported with the data.

10.3 If there is no explicit conditioning process, the conditioning process shall be reported as “unconditioned” and the moisture content as “unknown.”

11. Procedure

11.1 Parameters to Be Specified Before Test:

11.1.1 The specimen sampling method, specimen geometry, and conditioning travelers (if required).

11.1.2 The properties and data reporting format desired.

NOTE 4—Determine specific material property, accuracy, and data reporting requirements prior to test for proper selection of instrumentation and data recording equipment. Estimate the specimen strength to aid in transducer selection, calibration of equipment, and determination of equipment settings.

11.1.3 The environmental conditioning test parameters.

11.1.4 If performed, sampling method, specimen geometry, and test parameters used to determine facing density and reinforcement volume.

11.2 General Instructions:

11.2.1 Report any deviations from this test method, whether intentional or inadvertent.

11.2.2 If core density is to be reported, then obtain these samples from the same sheet of core being tested. Density may be evaluated in accordance with Test Method C271/C271M.

11.2.3 If specific gravity, density, facing reinforcement volume, or facing void volume are to be reported, then obtain these samples from the same panels being tested. Specific gravity and density may be evaluated in accordance with Test Methods D792. Volume percent of composite facing constituents may be evaluated by one of the matrix digestion procedures of Test Method Methods D3171, or, for certain reinforcement materials such as glass and ceramics, by the matrix burn-off technique in accordance with Test Method D2584. The void content equations of Test Method Methods D2734 are applicable to both Test Method D2584 and the matrix digestion procedures.