

INTERNATIONAL STANDARD



Magnetic materials –
Part 3: Methods of measurement of the magnetic properties of electrical steel strip and sheet by means of a single sheet tester.

iTeh Standards
Document Preview

[IEC 60404-3:2022](#)

<https://standards.iteh.ai/catalog/standards/iec/c1669eb3-9d7c-4aa5-9f26-bb9449afa74b/iec-60404-3-2022>



THIS PUBLICATION IS COPYRIGHT PROTECTED

Copyright © 2022 IEC, Geneva, Switzerland

All rights reserved. Unless otherwise specified, no part of this publication may be reproduced or utilized in any form or by any means, electronic or mechanical, including photocopying and microfilm, without permission in writing from either IEC or IEC's member National Committee in the country of the requester. If you have any questions about IEC copyright or have an enquiry about obtaining additional rights to this publication, please contact the address below or your local IEC member National Committee for further information.

IEC Secretariat
3, rue de Varembe
CH-1211 Geneva 20
Switzerland

Tel.: +41 22 919 02 11
info@iec.ch
www.iec.ch

About the IEC

The International Electrotechnical Commission (IEC) is the leading global organization that prepares and publishes International Standards for all electrical, electronic and related technologies.

About IEC publications

The technical content of IEC publications is kept under constant review by the IEC. Please make sure that you have the latest edition, a corrigendum or an amendment might have been published.

IEC publications search - webstore.iec.ch/advsearchform

The advanced search enables to find IEC publications by a variety of criteria (reference number, text, technical committee, ...). It also gives information on projects, replaced and withdrawn publications.

IEC Just Published - webstore.iec.ch/justpublished

Stay up to date on all new IEC publications. Just Published details all new publications released. Available online and once a month by email.

IEC Customer Service Centre - webstore.iec.ch/csc

If you wish to give us your feedback on this publication or need further assistance, please contact the Customer Service Centre: sales@iec.ch.

IEC Products & Services Portal - products.iec.ch

Discover our powerful search engine and read freely all the publications previews. With a subscription you will always have access to up to date content tailored to your needs.

Electropedia - www.electropedia.org

The world's leading online dictionary on electrotechnology, containing more than 22 300 terminological entries in English and French, with equivalent terms in 19 additional languages. Also known as the International Electrotechnical Vocabulary (IEV) online.

International Standards
Document Preview

[IEC 60404-3:2022](https://standards.iteh.ai/catalog/standards/iec/c1669eb3-9d7c-4aa5-9f26-bb9449afa74b/iec-60404-3-2022)

<https://standards.iteh.ai/catalog/standards/iec/c1669eb3-9d7c-4aa5-9f26-bb9449afa74b/iec-60404-3-2022>



IEC 60404-3

Edition 3.0 2022-11
REDLINE VERSION

INTERNATIONAL STANDARD



Magnetic materials –
Part 3: Methods of measurement of the magnetic properties of electrical steel strip and sheet by means of a single sheet tester

Document Preview

[IEC 60404-3:2022](https://standards.iteh.ai/catalog/standards/iec/c1669eb3-9d7c-4aa5-9f26-bb9449afa74b/iec-60404-3-2022)

<https://standards.iteh.ai/catalog/standards/iec/c1669eb3-9d7c-4aa5-9f26-bb9449afa74b/iec-60404-3-2022>

INTERNATIONAL
ELECTROTECHNICAL
COMMISSION

ICS 17.220.20; 29.030

ISBN 978-2-8322-6049-4

Warning! Make sure that you obtained this publication from an authorized distributor.

CONTENTS

| | |
|---|----|
| FOREWORD | 4 |
| 1 Object and field of application Scope | 6 |
| 2 Normative references | 7 |
| 3 Terms and definitions | 7 |
| 4 General principles of AC measurements | 7 |
| 4.1 General..... | 7 |
| 4.2 Principle of the single sheet tester method..... | 7 |
| 4.3 Test apparatus..... | 8 |
| 4.3.1 Yokes | 8 |
| 4.3.2 Windings | 10 |
| 4.4 Air flux compensation..... | 11 |
| 4.5 Test specimen | 11 |
| 4.6 Power supply | 12 |
| 5 Determination of the specific total loss | 12 |
| 5.1 Principle of measurement..... | 12 |
| 5.2 Apparatus | 12 |
| 5.2.1 Voltage measurement..... | 12 |
| 5.2.2 Frequency measurement | 13 |
| 5.2.3 Power measurement..... | 13 |
| 5.3 Measurement procedure of the specific total loss..... | 13 |
| 5.3.1 Preparation of measurement..... | 13 |
| 5.3.2 Source setting Adjustment of power supply..... | 13 |
| 5.3.3 Measurements..... | 14 |
| 5.3.4 Reproducibility of the measurement of the specific total loss | 15 |
| 6 Determination of magnetic field strength, excitation primary current and specific apparent power | 15 |
| 6.1 General..... | 15 |
| 6.2 Principle of measurement..... | 15 |
| 6.2.1 Peak value of the magnetic polarization..... | 15 |
| 6.2.2 RMS value the excitation primary current..... | 15 |
| 6.2.3 Peak value of the magnetic field strength | 16 |
| 6.3 Apparatus | 17 |
| 6.3.1 Average type voltmeter | 17 |
| 6.3.2 RMS current measurement | 17 |
| 6.3.3 Peak current measurement..... | 17 |
| 6.3.4 Power supply..... | 18 |
| 6.3.5 Resistor R_p R..... | 18 |
| 6.4 Measuring procedure | 18 |
| 6.4.1 Preparation for measurement | 18 |
| 6.4.2 Measurement..... | 18 |
| 6.4.3 Non-oriented material | 18 |
| 6.5 Determination of characteristics | 19 |
| 6.5.1 Determination of \hat{J} | 19 |
| 6.5.2 Determination of \tilde{H} | 19 |
| 6.5.3 Determination of \hat{H} | 20 |

| | | |
|--|---|----|
| 6.5.4 | Determination of S_S | 20 |
| 6.5.5 | Reproducibility of the measurement of the specific apparent power | 21 |
| 7 | Test report..... | 21 |
| Annex A (normative) | Requirements concerning the manufacture of yokes..... | 22 |
| Annex B (informative) – Calibration of the test apparatus with respect to the Epstein frame..... | | |
| Annex B (informative) | Check and verification of reliable performance of the SST set-up by the use of reference samples and impact of the loss dissipated in the yokes | 25 |
| Annex C (informative) | Epstein to SST relationship for grain-oriented steel sheet | 28 |
| Annex D (informative) | Digital sampling methods for the determination of the magnetic properties and numerical air flux compensation | 32 |
| D.1 | General..... | 32 |
| D.2 | Technical details and requirements | 32 |
| D.3 | Calibration aspects | 34 |
| D.4 | Numerical air flux compensation | 35 |
| Bibliography | | 36 |
| Figure 1 – Schematic diagrammes of the test apparatus | | 9 |
| Figure 2 – Yoke dimensions..... | | 10 |
| Figure 3 – Diagram of the connections of the five coils of the primary winding | | 10 |
| Figure 4 – Circuit for the determination of the specific total loss..... | | 11 |
| Figure 5 – Circuit for measuring the RMS value of the excitation primary current..... | | 16 |
| Figure 6 – Circuit for measuring the peak value of the magnetic field strength | | 17 |
| Figure B.1 – Specific total loss vs. peak flux density (after J.Sievert [3] and G. Bertotti [4]); straight line: $P_S \propto B^{1.85}$ approximation (after C.Ragusa). | | 26 |
| Figure C.1 – Epstein-SST conversion factor δP SST-Epstein relative difference δP for conventional grain-oriented material versus magnetic polarization $\downarrow J$ | | 30 |
| Figure C.2 – Epstein-SST conversion factor δHS SST-Epstein relative difference δHS for conventional grain-oriented material versus magnetic polarization $\downarrow J$ | | 31 |
| Table B.1 – Loss dissipated by the yokes of a standard SST, determined from the loss curves measured on 3 yoke pairs as shown in Figure B.1, and relevant quantities including the relative yokes' contribution, p_Y ; exemplified using 5 standard grades..... | | 27 |
| Table C.1 – Epstein-SST conversion factors δP and δHS SST-Epstein relative differences δP and δHS and the conversion factor F_C for conventional grain-oriented material in the polarization range 1,0 T to 1,8 T | | 30 |

INTERNATIONAL ELECTROTECHNICAL COMMISSION

MAGNETIC MATERIALS –

Part 3: Methods of measurement of the magnetic properties of electrical steel strip and sheet by means of a single sheet tester

FOREWORD

- 1) The International Electrotechnical Commission (IEC) is a worldwide organization for standardization comprising all national electrotechnical committees (IEC National Committees). The object of IEC is to promote international co-operation on all questions concerning standardization in the electrical and electronic fields. To this end and in addition to other activities, IEC publishes International Standards, Technical Specifications, Technical Reports, Publicly Available Specifications (PAS) and Guides (hereafter referred to as “IEC Publication(s)”). Their preparation is entrusted to technical committees; any IEC National Committee interested in the subject dealt with may participate in this preparatory work. International, governmental and non-governmental organizations liaising with the IEC also participate in this preparation. IEC collaborates closely with the International Organization for Standardization (ISO) in accordance with conditions determined by agreement between the two organizations.
- 2) The formal decisions or agreements of IEC on technical matters express, as nearly as possible, an international consensus of opinion on the relevant subjects since each technical committee has representation from all interested IEC National Committees.
- 3) IEC Publications have the form of recommendations for international use and are accepted by IEC National Committees in that sense. While all reasonable efforts are made to ensure that the technical content of IEC Publications is accurate, IEC cannot be held responsible for the way in which they are used or for any misinterpretation by any end user.
- 4) In order to promote international uniformity, IEC National Committees undertake to apply IEC Publications transparently to the maximum extent possible in their national and regional publications. Any divergence between any IEC Publication and the corresponding national or regional publication shall be clearly indicated in the latter.
- 5) IEC itself does not provide any attestation of conformity. Independent certification bodies provide conformity assessment services and, in some areas, access to IEC marks of conformity. IEC is not responsible for any services carried out by independent certification bodies.
- 6) All users should ensure that they have the latest edition of this publication.
- 7) No liability shall attach to IEC or its directors, employees, servants or agents including individual experts and members of its technical committees and IEC National Committees for any personal injury, property damage or other damage of any nature whatsoever, whether direct or indirect, or for costs (including legal fees) and expenses arising out of the publication, use of, or reliance upon, this IEC Publication or any other IEC Publications.
- 8) Attention is drawn to the Normative references cited in this publication. Use of the referenced publications is indispensable for the correct application of this publication.
- 9) Attention is drawn to the possibility that some of the elements of this IEC Publication may be the subject of patent rights. IEC shall not be held responsible for identifying any or all such patent rights.

This redline version of the official IEC Standard allows the user to identify the changes made to the previous edition IEC 60404-3:1992+AMD1:2002+AMD2:2009 CSV. A vertical bar appears in the margin wherever a change has been made. Additions are in green text, deletions are in strikethrough red text.

IEC 60404-3 has been prepared by IEC technical committee 68: Magnetic alloys and steels. It is an International Standard.

This third edition cancels and replaces the second edition published in 1992, Amendment 1:2002 and Amendment 2:2009. This edition constitutes a technical revision.

This edition includes the following significant technical changes with respect to the previous edition:

- a) Annex A was revised. The method of determining the yokes' lamination resistance was added to Annex A;
- b) Annex B of the consolidated version of 2010 referred to calibration of the SST using the Epstein method. It was cancelled;
- c) Annex B (new), Annex C and Annex D were revised, they are for information only;
- d) Annex C was modified taking account of the new situation regarding P and R grades;
- e) Annex D was amended by addition of Clause D.4 on the numerical air flux compensation.

The text of this International Standard is based on the following documents:

| Draft | Report on voting |
|------------|------------------|
| 68/699/CDV | 68/710/RVC |

Full information on the voting for its approval can be found in the report on voting indicated in the above table.

The language used for the development of this International Standard is English.

This document was drafted in accordance with ISO/IEC Directives, Part 2, and developed in accordance with ISO/IEC Directives, Part 1 and ISO/IEC Directives, IEC Supplement, available at www.iec.ch/members_experts/refdocs. The main document types developed by IEC are described in greater detail at www.iec.ch/publications.

A list of all parts in the IEC 60404 series, published under the general title *Magnetic materials*, can be found on the IEC website.

The committee has decided that the contents of this document will remain unchanged until the stability date indicated on the IEC website under webstore.iec.ch in the data related to the specific document. At this date, the document will be

- reconfirmed,
- withdrawn,
- replaced by a revised edition, or
- amended.

IMPORTANT – The "colour inside" logo on the cover page of this document indicates that it contains colours which are considered to be useful for the correct understanding of its contents. Users should therefore print this document using a colour printer.

MAGNETIC MATERIALS –

Part 3: Methods of measurement of the magnetic properties of electrical steel strip and sheet by means of a single sheet tester

1 ~~Object and field of application~~ Scope

This part of IEC 60404 is applicable to grain-oriented and non-oriented electrical steel strip and sheet for measurement of AC magnetic properties at power frequencies.

The object of this document is to define the general principles and the technical details of the measurement of the magnetic properties of ~~magnetic sheets~~ electrical steel strip and sheet by means of a single sheet tester (SST).

~~This part of IEC 60404 is applicable at power frequencies to:~~

~~a) grain-oriented magnetic sheet and strip:~~

~~for the measurement between 1,0 T and 1,8 T of:~~

~~— specific total loss;~~

~~— specific apparent power;~~

~~— r.m.s. value of the magnetic field strength;~~

~~for the measurement up to peak values of magnetic field strength of 1 000 A/m of:~~

~~— peak value of the magnetic polarization;~~

~~— peak value of the magnetic field strength.~~

~~b) non-oriented magnetic sheet and strip:~~

~~for the measurement between 0,8 T and 1,5 T of:~~

~~— specific total loss;~~

~~— specific apparent power;~~

~~— r.m.s. value of excitation current;~~

~~for the measurement up to peak values of magnetic field strength of 10 000 A/m of:~~

~~— peak value of the magnetic polarization;~~

~~— peak value of the magnetic field strength.~~

The single sheet tester is applicable to test specimens obtained from ~~magnetic sheets and strips of any quality~~ electrical steel strips and sheets of any grade. The AC magnetic characteristics are determined for sinusoidal induced voltages, for specified peak values of the magnetic polarization, for specific peak values of the magnetic field strength and for a specified frequency.

The measurements are made at an ambient temperature of $(23 \pm 5)^\circ\text{C}$ on test specimens which have first been demagnetized.

NOTE Throughout this document, the quantity "magnetic polarization" is used as defined in ~~IEC 60050(901)~~ IEC 60050-221. In some standards of the IEC 60404 series, the quantity "magnetic flux density" was used.

In order to support the long-term reliability of the performance of this set up and to understand better the relationship between the Epstein method and the SST method, the informative Annexes B and C, respectively, have been included.

2 Normative references

The following documents are referred to in the text in such a way that some or all of their content constitutes requirements of this document. For dated references, only the edition cited applies. For undated references, the latest edition of the referenced document (including any amendments) applies.

IEC 60050-121, *International Electrotechnical Vocabulary – Part 121: Electromagnetism*

IEC 60050-221, *International Electrotechnical Vocabulary – Part 221: Magnetic materials and components*

~~IEC 60404-2, *Magnetic materials – Part 2: Methods of measurement of the magnetic properties of electrical steel strip and sheet by means of an Epstein frame*~~

IEC 60404-13, *Magnetic materials – Part 13: Methods of measurement of resistivity, density and stacking factor of electrical steel strip and sheet*

3 Terms and definitions

For the purposes of this document, the terms and definitions given in IEC 60050-121 and IEC 60050-221 apply.

ISO and IEC maintain terminological databases for use in standardization at the following addresses:

- IEC Electropedia: available at <https://www.electropedia.org/>
- ISO Online browsing platform: available at <https://www.iso.org/obp>

4 General principles of AC measurements 2022

<https://standards.iteh.ai/catalog/standards/iec/c1669eb3-9d7c-4aa5-9f26-bb9449afa74b/iec-60404-3-2022>

4.1 General

Clause 4 specifies the general conditions for the determination of AC magnetic properties of electrical steel strip and sheet at power frequencies by means of a single sheet tester.

4.2 Principle of the single sheet tester method

The test specimen comprises a sample of ~~magnetic~~ electrical steel sheet and is placed ~~inside~~ in the center of two concentric windings:

- an exterior primary winding (magnetizing winding);
- an interior secondary winding (voltage winding).

The flux closure is made by a magnetic circuit consisting of two identical yokes, the cross-section of which is very large compared with that of the test specimen (see Figure 1).

~~To minimize the effects of pressure on the test specimen, the upper yoke shall be provided with a means of suspension which allows part of its weight to be counterbalanced in accordance with 3.2.1.~~

~~Care shall be taken to ensure that~~ The temperature changes of the specimen ~~are~~ shall be kept below a level likely to produce stress in the test specimen due to thermal expansion or contraction.

4.3 Test apparatus

4.3.1 Yokes

Each yoke is in the form of a U made up of insulated sheets of grain-oriented ~~silicon~~ electrical steel ~~or nickel iron alloy~~. It shall have a low reluctance and a low specific total loss ~~not greater than 1,0 W/kg at 1,5 T and 50 Hz~~ in the low magnetic polarization region below 0,2 T (see Annex A). It shall be manufactured in accordance with the requirements of Annex A.

In order to reduce the effect of eddy currents and give a more homogeneous distribution of the flux over the inside of the yokes, the ~~latter~~ yokes shall be made of a pair of wound cut C-cores or a glued stack of laminations in which case the corners shall have staggered butt joints (see Figure 1).

The yoke shall have pole faces having a width of 25 mm ± 1 mm.

The two pole faces of each yoke shall be coplanar to within 0,5 mm and the gap between the opposite pole faces of the yokes shall not exceed 0,005 mm at any point. Also, the yokes shall be rigid in order to avoid creating mechanical stresses such as twisting, tensioning and compression in the test specimen.

The height of each yoke shall be between 90 mm and 150 mm. Each yoke shall have a width of 500⁺⁵₀ mm and an inside length of 450 mm ± 1 mm (see Figure 2).

~~NOTE— It is recognized that other yoke dimensions can be used provided that the comparability of the results can be demonstrated.~~

There shall be a non-conducting, non-magnetic support on which the test specimen is placed, between the vertical limbs of the bottom yokes. This support shall be centered and located in the same plane as the bottom yoke pole faces so that the test specimen is in direct contact with the pole faces without any gap. Care shall be taken that in no case the upper surface of the support is positioned higher than the plane of the pole faces of the bottom yoke.

IEC 60404-3:2022

<https://standards.iteh.ai/catalog/standards/iec/c1669eb3-9d7c-4aa5-9f26-bb9449afa74b/iec-60404-3-2022>

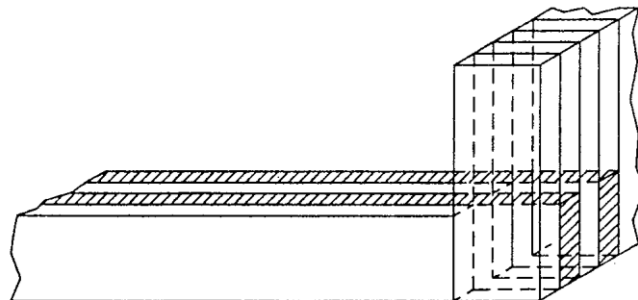
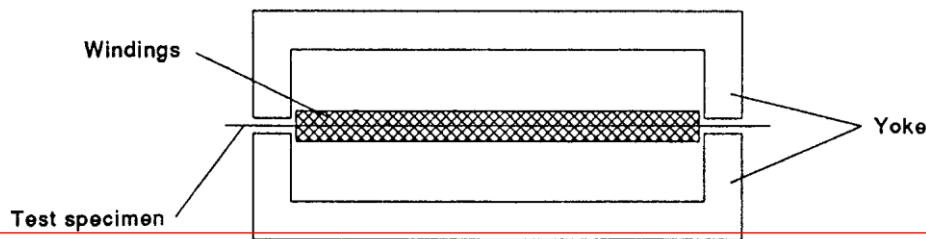

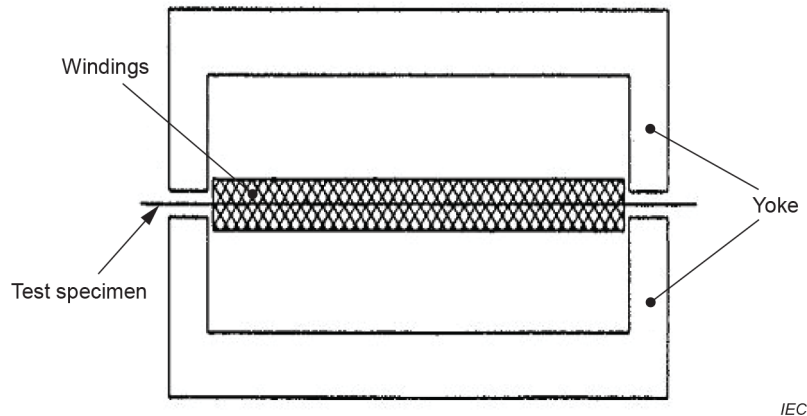

a) Cross-section of the SST

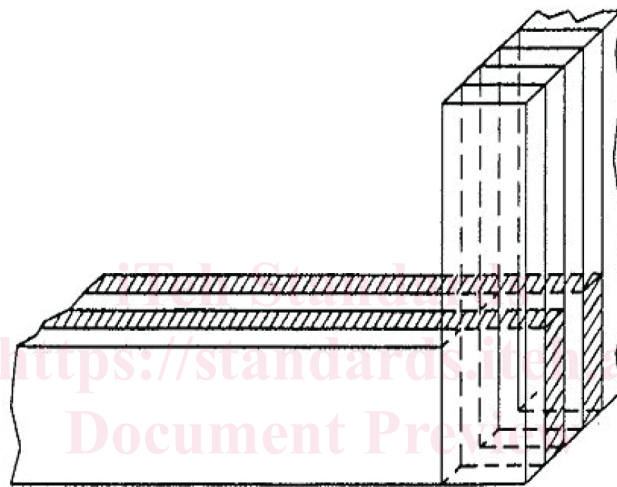

b) Schematic view of the corner of a yoke with stacked lamination

Figure 1 – Schematic diagrammes of the test apparatus

The upper yoke shall be movable upwards to permit insertion of the test specimen. ~~After insertion the upper yoke shall be realigned accurately with the bottom yoke.~~ After insertion of the test specimen, the upper yoke shall be lowered to close the magnetic circuit and, simultaneously, the pole faces of the bottom and upper yokes shall be aligned accurately. To minimize the effects of pressure on the test specimen, the upper yoke shall be provided with a means of suspension. The suspension of the upper yoke shall allow part of its weight to be counterbalanced so as to give a force on the test specimen of between 100 N and 200 N.

NOTE The square ~~shape~~ configuration of the yoke has been chosen in order to have only one test specimen for non-oriented material. By rotating the test specimen through 90°, it is possible to determine the characteristics in the rolling direction and perpendicular to the rolling direction.

Dimensions in millimetres

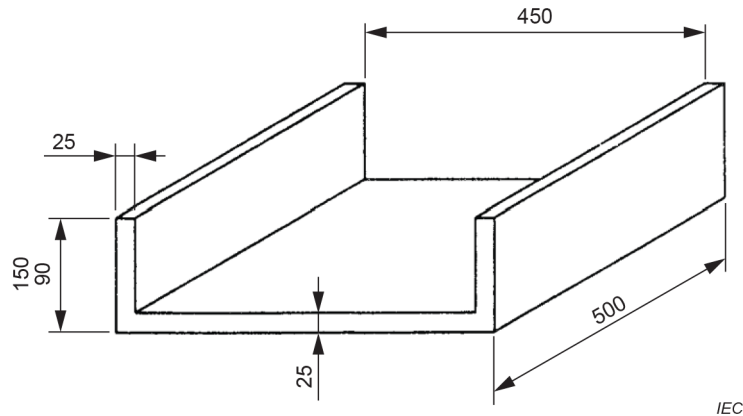

Figure 2 – Yoke dimensions

4.3.2 Windings

The coil system inside the yokes shall have two windings:

- a primary winding, on the outside (magnetizing winding);
- a secondary winding, on the inside (voltage winding);

The primary (outer) and secondary (inner) windings shall be at least 440 mm in length and shall be wound uniformly on a non-conducting, non-magnetic and rectangular former. The dimensions of the former shall be as follows:

- length: 445 mm ± 2 mm;
- internal width: 510 mm ± 1 mm;
- internal height: 5_{-2}^0 mm;
- height: ≤ 15 mm.

The primary winding can be made up of:

- either five or more coils having identical dimensions and the same number of turns connected in parallel and taking up the whole length (see Figure 3). For example, with five coils, each coil can be made up of 400 turns of copper wire 1 mm in diameter, wound in five layers;
- or a single continuous and uniform winding taking up the whole length. For example, this winding can be made up of 400 turns of copper wire 1 mm in diameter, wound in one ~~or~~ **more layers** layer.

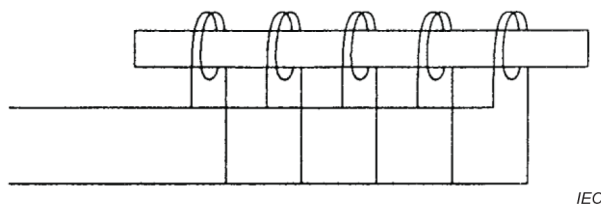
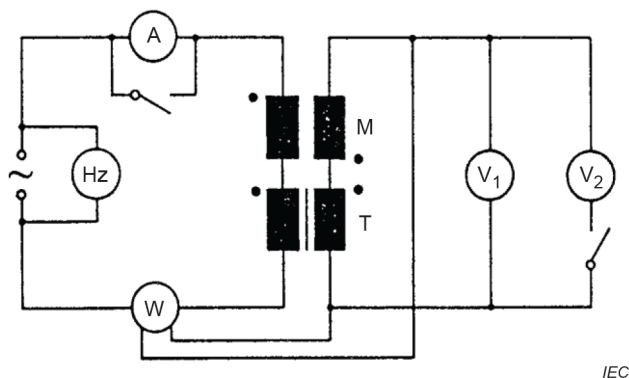

Figure 3 – Diagram of the connections of the five coils of the primary winding

The number of turns on the secondary winding will depend on the characteristics of the measuring instruments. In any case, the determination of the number of turns of the primary and secondary windings shall be made with greatest reliability because a mistake would mean a permanent error.

4.4 Air flux compensation

Compensation shall be made for the effect of air flux. This can be achieved, for example, by a mutual inductor M (see Figure 4). The primary winding of the mutual inductor is connected in series with the primary winding of the test apparatus, while the secondary winding of the mutual inductor is connected to the secondary winding of the test apparatus in series opposition.



IEC

Key

V_1 is the voltmeter that measures the average rectified voltage;

V_2 is the voltmeter that measures the RMS voltage;

A is the ammeter that measures the RMS value of the primary current;

Hz that measures the frequency;

W that measures the power;

M is the mutual inductor;

T is the test frame.

Figure 4 – Circuit for the determination of the specific total loss

The adjustment of the value of the mutual inductance shall be made so that when passing an alternating current through the primary windings in the absence of the test specimen in the test apparatus, the voltage measured between the non-common terminals of the secondary windings shall be no more than 0,1 % of the voltage appearing across the secondary winding of the test apparatus alone. Thus, the average value of the rectified voltage induced in the combined secondary windings is proportional to the peak value of the magnetic polarization in the test specimen.

NOTE 1 Alternatively, the air flux compensation can be executed by the numerical method (for details, see Annex D, Clause D.4).

NOTE 2 In the rest of this document, the term “compensated secondary voltage” is used to mean “voltage induced in the secondary winding compensated for the effect of air flux”.

4.5 Test specimen

The length of the test specimen shall be not less than 500 mm. Although the part of the test specimen situated outside the pole faces has no great influence on the measurement, this part shall not be longer than is necessary to facilitate insertion and removal of the test specimen.

The width of the test specimen shall be as large as possible and at its maximum equal to the width of the yokes.

For ~~maximum~~ optimum accuracy, the minimum width shall be not less than 60 % of the width of the yokes.

NOTE 1 Specific restrictions of the dimensions of the test specimens can be defined for special material grades in the respective product standards for magnetic materials.

NOTE 2 Information about application of the SST to strip samples of 50 mm to 250 mm width: Grain-oriented electrical steel used for distribution transformer (DT) cores is merchandized in the form of slit coils of 50 mm to 250 mm width cut from the as produced steel strips (parent coils) at the different positions across the original strips. The slit coils reflect the considerable variation of the material properties corresponding to the position on the original strip, where they have been cut from. These small strip specimens can be measured using this SST placing them side by side or with distributed gaps in the SST. In order to obtain a relevant measurement result, a minimum of 60 % of the 500 mm wide sample space needs to be filled with strips. The test strip samples can be taken successively from the start or the end of a slit coil. When preparing them taking care would avoid any damage which could influence the test result. Due to the cutting of the sheet into the small strips, the measured loss of narrow strips will be slightly increased compared to the original 500 mm.

The test specimen shall be cut without the formation of excessive burrs or mechanical distortion. The test specimen shall be plane. When a test specimen is cut, the edge of the parent ~~strip~~ coil is taken as the reference direction. ~~The following tolerances are allowed for~~ The angle between the direction of rolling and that of cutting shall not exceed:

- ±1° for grain oriented steel sheet;
- ±5° for non-oriented steel sheet.

For non-oriented steel sheet, two specimens shall be cut, one parallel to the direction of rolling and the other perpendicular unless the test specimen is square, in which case one test specimen only is necessary.

4.6 Power supply

The power supply shall be of low internal impedance and shall be highly stable in terms of voltage and frequency. During the measurement, the voltage and the frequency shall be maintained constant within ±0,2 %.

In addition, the waveform of the compensated secondary ~~induced~~ voltage shall be maintained as sinusoidal as possible. ~~It is preferable to maintain~~ The form factor of the compensated secondary voltage shall be maintained to within ±1 % of 1,111. This can be achieved by various means, for example by using an electronic feedback amplifier or by a computational digital feedback system.

5 Determination of the specific total loss

5.1 Principle of measurement

The ~~single sheet tester~~ test apparatus with the inserted test specimen represents an unloaded transformer the total loss of which is measured by the circuit shown in Figure 4.

5.2 Apparatus

5.2.1 Voltage measurement

~~NOTE—For the application of digital sampling methods, see Annex D.~~

5.2.1.1 Average type voltmeter

~~The secondary rectified voltage of the test apparatus~~ The average rectified value of the compensated secondary voltage shall be measured by an average type voltmeter. The preferred instrument is a digital voltmeter having an ~~accuracy~~ uncertainty of ±0,2 % or better.

NOTE 1 Instruments of this type are usually graduated in average rectified value multiplied by 1,111.

The load on the secondary circuit shall be as small as possible. Consequently, the internal resistance of the average type voltmeter should be at least 1 000 Ω/V.

NOTE 2 For the application of digital sampling methods, see Annex D.