



Designation: **C1809—16 C1809 – 19**

Standard Practice for Preparation of Specimens and Reporting of Results for Permeance Testing of Pressure Sensitive Adhesive Sealed Joints in Insulation Vapor Retarders¹

This standard is issued under the fixed designation C1809; the number immediately following the designation indicates the year of original adoption or, in the case of revision, the year of last revision. A number in parentheses indicates the year of last reappraisal. A superscript epsilon (ϵ) indicates an editorial change since the last revision or reappraisal.

1. Scope

1.1 This practice provides instruction for the preparation of test specimens of pressure sensitive adhesive (~~psa~~(PSA) sealed joints of the type employed in insulation vapor retarder systems, for subsequent testing per Test Methods E96/E96M to determine the water vapor permeance (“permeance”) of those joints. It does not cover preparation of other types of joints.

1.2 This practice ~~also~~ provides requirements for the content of reports issued in conjunction with Test Methods E96/E96M testing of these joints.

1.3 Joints are made with factory coated ~~psa~~PSA tapes or ~~psa~~PSA coated laminate jacket (vapor retarder cladding) materials.

1.3.1 The types of materials and joints to be tested are generally encountered in mechanical systems in commercial and industrial insulation applications, and in HVAC systems insulation.

1.3.2 Typical ~~psa~~PSA joints that are employed in vapor retarder systems for mechanical insulation include:

1.3.2.1 Overlap with double-sided tape.

1.3.2.2 Overlap with coated laminate jacket.

1.3.2.3 Butt with single-sided insulation tape.

1.3.2.4 Intersection of overlap and butt joint.

1.4 Test Methods E96/E96M ~~is~~are to be followed for specific testing instruction beyond the areas of guidance provided herein, that is, after the specimens are prepared in the desired test configuration.

1.5 The values stated in inch-pound units are to be regarded as standard. The values given in parentheses are mathematical conversions to SI units that are provided for information only and are not considered standard.

1.6 *This standard does not purport to address all of the safety concerns, if any, associated with its use. It is the responsibility of the user of this standard to establish appropriate ~~safety~~ safety, health, and ~~health~~ environmental practices and determine the applicability of regulatory limitations prior to use.*

1.7 *This international standard was developed in accordance with internationally recognized principles on standardization established in the Decision on Principles for the Development of International Standards, Guides and Recommendations issued by the World Trade Organization Technical Barriers to Trade (TBT) Committee.*

2. Referenced Documents

2.1 *ASTM Standards:*²

C1775 Specification for Laminate Protective Jacket and Tape for Use over Thermal Insulation for Outdoor Applications

E96/E96M Test Methods for Water Vapor Transmission of Materials

C168 Terminology Relating to Thermal Insulation

3. Terminology

3.1 *Definitions:*

3.1.1 *laminate jacket*—see Specification C1775.

¹ This practice is under the jurisdiction of ASTM Committee C16 on Thermal Insulation and is the direct responsibility of Subcommittee C16.40 on Insulation Systems. Current edition approved March 1, 2016; Sept. 1, 2019. Published April 2016; September 2019. Originally approved in 2015. Last previous edition approved in 2015 as C1809—15; C1809 – 16. DOI: 10.1520/C1809-16; 10.1520/C1809-19.

² For referenced ASTM standards, visit the ASTM website, www.astm.org, or contact ASTM Customer Service at service@astm.org. For *Annual Book of ASTM Standards* volume information, refer to the standard’s Document Summary page on the ASTM website.

3.1.2 *water vapor permeance, water vapor barrier*—see Terminology **C168**.

3.2 *Definitions of Terms Specific to This Standard:*

3.2.1 *pressure sensitive adhesive, n*—an adhesive that requires some degree of pressure, and only pressure, to adequately bond to a substrate.

3.2.2 *SSL tape, n*—A pressure sensitive, double-sided “Self Sealing Lap” tape that is commonly used to seal the longitudinal overlap joint in pipe insulation jacketing.

4. Summary of Practice

4.1 Specimen preparation as directed herein addresses configuration and sealing of psaPSA joints for subsequent permeance testing.

4.2 The permeance test ~~itself~~ is performed per Test Methods **E96/E96M**.

5. Significance and Use

5.1 PSA joints are a necessary and critical component of an insulation vapor retarder system and, in addition to knowing the permeance of the vapor retarder being used, assessing the permeance of the joints is necessary to indicate the expected performance of the system.

5.2 Test Methods **E96/E96M** ~~does do~~ not include instructions specific to preparing multiple-piece assemblies such as psaPSA joints. This practice provides those instructions.

5.3 There are a number of variables involved in making a psa joint, and those need to be considered in specimen preparation and data reporting. Such variables include:

5.3.1 Means of applying pressure to seal the joint,

5.3.2 Amount of pressure applied,

5.3.3 Dwell time prior to test,

5.3.4 Backing surface upon which joint is prepared,

5.3.5 Ambient conditions for specimen preparation,

5.3.6 Dimensions of materials,

5.3.7 Configuration of joint,

5.3.8 Dish size,

5.3.9 Test area of specimen, and

5.3.10 Area of joint.

5.4 It is not likely that field-installed joints will achieve as good a seal as those prepared in the laboratory. Field installations ~~can often~~ involve extremes in ambient conditions, surface contamination, limited space, varying pipe radii, varying pressure applied, and variation in base insulation density and rigidity.

5.4.1 Results obtained through application of this practice and Test Methods **E96/E96M** are best used to compare materials and configurations. It is urged not to equate actual field performance with the results obtained in a laboratory setting.

6. Procedure

6.1 ~~Use an aluminum~~ a test dish with nominal outside diameter of 6 in. (152 mm) and specimen template with nominal outside diameter of 5.75 in. (146 mm) of any dimension, circular or rectangular.

6.2 Use a wax damming plate that produces an exposed specimen test surface diameter of 5.25 in. (133.5 mm) surface. When using a circular dish, measure the diameter of the exposed portion of the specimen. Measure the length and the width of the exposed surface of the specimen when using a rectangular dish.

6.3 Prepare specimens on a flat, smooth, hard and rigid surface, such as laboratory bench top, under standard conditions of 73° ± 2°F (23° ± 0.7°C) and 50 ± 5% RH.

6.4 ~~Butt Joints:~~

6.4.1 ~~Position the tape centered over two adjacent sheets of vapor retarder (see Fig. 1):~~

6.4.2 ~~Separate the two sheets by a gap of 0.5 in. (12 mm) to duplicate a nominal field installation gap, centered in the dish.~~

6.4.3 ~~Apply a 3 in. (76 mm) wide tape, centered over the gap.~~

6.5 ~~Self-Sealing Overlap Joints:~~

6.5.1 ~~Position the tape and vapor retarder sheets, or cladding sheets, so that there is a 1 in. (25 mm) overlap (see Fig. 2):~~

6.5.2 ~~Center the exposed edge in the dish.~~

6.4 Overlap Seams with Single-Sided Tape Covering: See **Annex A1** for examples of butt joints, overlap seam with double sided taped joints, and overlap seam with single sided taped joints. The dimensions given in **Annex A1** are for information only. Specimen dimensions are determined by the user.

6.6.1 Overlap the vapor retarder by 1 in. (25 mm) with exposed lap edge centered in dish.

6.6.2 Center a 3 in. (75 mm) single-sided tape over the exposed lap edge (see Fig. 3).

6.5 In all cases, make the vapor retarder sheet somewhat larger than the test specimen dimensions, then trim to correct size after making joint(s).

6.6 To seal the joint, use a 4 in. (102 mm) wide plastic tape applicator squeegee, available from insulation tape suppliers.

6.6.1 Apply a manual force of nominally 5 lbs-lb (2.3 kg) when rubbing the joint with the squeegee.

6.6.1.1 Practice exerting this force by applying the rubbing motion on a flat digital scale of 10-20 lb. (4.5-9.0 kg) to 20 lb (4.5 to 9.0 kg) capacity.

6.6.2 Rub down the joint using two passes in one direction only.

6.7 Do not apply additional force or passes to any parts of the joint.

6.8 If one surface of the vapor retarder or tape is hygroscopic (such as standard ASJ with exposed paper), test with non-hygroscopic side up. (In this case the joint is “upside down”, but this should not affect moisture ingress.)

7. Test Methods

7.1 Test Methods E96/E96M is to be used, employing a wax/resin seal.

7.2 Test the vapor retarder material by itself (without joints) without joints to establish its permeance.

7.3 Test the specimens with joints.

NOTE 1—Per Test Methods E96/E96M, for a given configuration, three or four specimens, plus a dummy blank specimen, are tested.

7.4 Any test chamber conditions may be employed. The following are either commonly used, or may be appropriate for expected end use conditions or specification requirements:

7.4.1 Test Methods E96/E96M Procedure A, desiccant method at 73°F (23°C).

7.4.2 Test Methods E96/E96M Procedure B, water method at 73°F (23°C).

7.4.3 Test Methods E96/E96M Procedure E, desiccant method at 100°F (38°C).

8. Calculation of Result Calculations

8.1 Permeance of the PSA joint is based on the area of the joint. The calculation method for the area of the joint for circular specimen is contained in 8.1.1. The calculation method for the area of square or rectangular specimen is contained in 8.1.2.

8.1.1 Fig. 1 contains a drawing showing the various elements needed for calculating the areas of the circular segments.

8.1.1.1 The nomenclature used in the following equations for calculating the areas of the various circular segments is as follows:

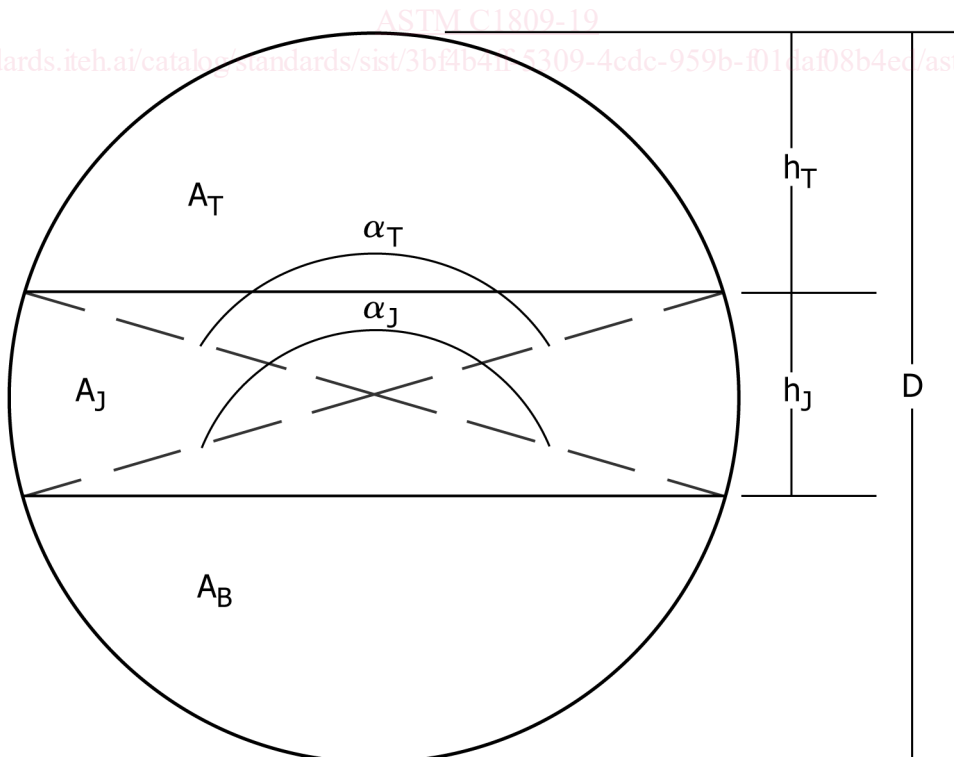

FIG. 1 Nomenclature of Specimen Circular Segments

- D ≡ Measured diameter of the exposed portion of the specimen (in.)
- r ≡ Radius of the exposed portion of the specimen (in.)
- A_{total} ≡ Total area of the exposed portion of the specimen (in.²)
- a_T ≡ Angle of the chord from the top portion of the taped joint (degrees)
- h_T ≡ Measured height of the top portion of the specimen to the joint (in.)
- A_T ≡ Area of the exposed portion of the top of the specimen (in.)
- a_J ≡ Angle of the chord from the bottom portion of the taped joint (degrees)
- h_J ≡ Measured height (width) of the taped joint of the specimen (in.)
- A_J ≡ Area of the exposed portion of the joint of the specimen (in.²)
- A_B ≡ Area of the exposed portion of the bottom of the specimen (in.²)

8.1.1.2 Calculation of segment areas for cylindrical specimen are given in the following equations:

$$r = 0.5 \cdot D \tag{1}$$

$$A_{total} = \pi r^2 \tag{2}$$

$$a_T = 2 \cdot \frac{180}{\pi} \cdot ACOS \left(1 - \left(\frac{h_T}{r} \right) \right) \tag{3}$$

$$A_T = 0.5 \cdot r^2 \cdot \left(\left(\frac{\pi}{180} \right) a_T - SIN \left(\left(\frac{\pi}{180} \right) a_T \right) \right) \tag{4}$$

$$a_J = 2 \cdot \frac{180}{\pi} \cdot ACOS \left(1 - \left(\frac{h_T + h_J}{r} \right) \right) \tag{5}$$

$$A_J = 0.5 \cdot r^2 \cdot \left(\left(\frac{\pi}{180} \right) a_J - SIN \left(\left(\frac{\pi}{180} \right) a_J \right) \right) - A_T \tag{6}$$

$$A_B = A_{total} - A_T - A_J \tag{7}$$

8.1.2 Fig. 2 contains a figure showing the various elements needed for calculating the areas of the rectangular segments.

8.1.2.1 The nomenclature used in the following equations for calculating the areas of the various rectangular segments is as follows:

- l ≡ Measured length of the exposed portion of the specimen (in.)
- A_{total} ≡ Total area of the exposed portion of the specimen (in.²)
- W_T ≡ Measured width of the exposed portion of the top of specimen to the joint (in.)
- W_J ≡ Measured width of the exposed portion of the specimen joint (in.)
- W_B ≡ Measured width of the exposed portion of the bottom of the specimen (in.)
- A_T ≡ Area of the top portion of the specimen (in.²)
- A_J ≡ Area of the taped joint portion of the specimen (in.²)
- A_B ≡ Area of the bottom portion of the specimen (in.²)

8.1.2.2 Calculation of segment areas for rectangular specimen are given in the following equations:

$$A_{total} = l \cdot (w_T + w_J + w_B) \tag{8}$$

$$A_T = l \cdot w_T \tag{9}$$

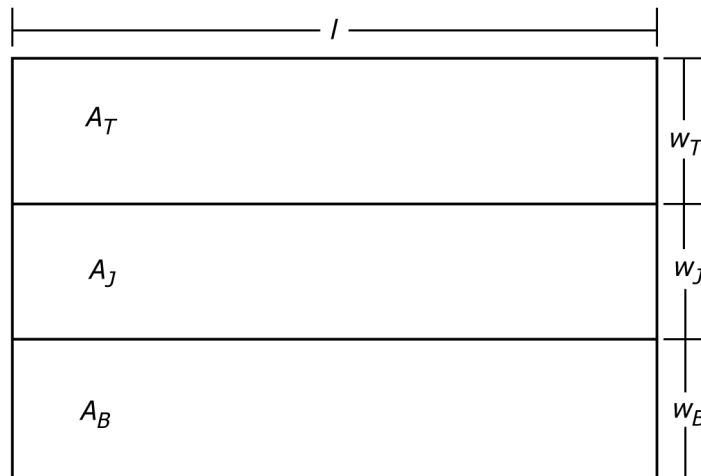

FIG. 2 Nomenclature for Rectangular Specimen