



Designation: **B108/B108M—18<sup>e1</sup>** **B108/B108M – 19**

## Standard Specification for Aluminum-Alloy Permanent Mold Castings<sup>1</sup>

This standard is issued under the fixed designation B108/B108M; the number immediately following the designation indicates the year of original adoption or, in the case of revision, the year of last revision. A number in parentheses indicates the year of last reappraisal. A superscript epsilon ( $\epsilon$ ) indicates an editorial change since the last revision or reappraisal.

*This standard has been approved for use by agencies of the U.S. Department of Defense.*

<sup>e1</sup> NOTE—Footnote B of Table 3 was revised editorially in August 2018.

### 1. Scope\*

- 1.1 This specification<sup>2</sup> covers aluminum-alloy permanent mold castings designated as shown in **Table 1**.
- 1.2 This specification is for aluminum-alloy permanent mold castings used in general purpose applications. It may not address the mechanical properties, integrity testing, and verification required for highly loaded or safety critical applications.
- 1.3 Alloy and temper designations are in accordance with ANSI H35.1/H35.1(M).
- 1.4 Unless the order specifies the “M” specification designation, the material shall be furnished to the inch-pound units.
- 1.5 For acceptance criteria for inclusion of new aluminum and aluminum alloys and their properties in this specification, see **Annex A1 and Annex A2**.
- 1.6 *Units*—The values stated in either SI units or inch-pound units are to be regarded separately as standard. The values stated in each system may not be exact equivalents; therefore, each system shall be used independently of the other. Combining values from the two systems may result in non-conformance with the standard.
- 1.7 *This standard does not purport to address all of the safety concerns, if any, associated with its use. It is the responsibility of the user of this standard to establish appropriate safety, health, and environmental practices and determine the applicability of regulatory limitations prior to use.*
- 1.8 *This international standard was developed in accordance with internationally recognized principles on standardization established in the Decision on Principles for the Development of International Standards, Guides and Recommendations issued by the World Trade Organization Technical Barriers to Trade (TBT) Committee.*

### 2. Referenced Documents

2.1 The following documents of the issue in effect on the date of casting purchase form a part of this specification to the extent referenced herein:

2.2 *ASTM Standards*:<sup>3</sup>

- B179** Specification for Aluminum Alloys in Ingot and Molten Forms for Castings from All Casting Processes
- B275** Practice for Codification of Certain Zinc, Tin and Lead Die Castings
- B557** Test Methods for Tension Testing Wrought and Cast Aluminum- and Magnesium-Alloy Products
- B557M** Test Methods for Tension Testing Wrought and Cast Aluminum- and Magnesium-Alloy Products (Metric)
- B660** Practices for Packaging/Packing of Aluminum and Magnesium Products
- B666/B666M** Practice for Identification Marking of Aluminum and Magnesium Products
- B881** Terminology Relating to Aluminum- and Magnesium-Alloy Products
- B917/B917M** Practice for Heat Treatment of Aluminum-Alloy Castings from All Processes
- B985** Practice for Sampling Aluminum Ingots, Billets, Castings and Finished or Semi-Finished Wrought Aluminum Products for Compositional Analysis

<sup>1</sup> This specification is under the jurisdiction of ASTM Committee **B07** on Light Metals and Alloys and is the direct responsibility of Subcommittee **B07.01** on Aluminum Alloy Ingots and Castings.

Current edition approved ~~May 15, 2018~~ ~~Sept. 1, 2019~~ ~~Published May 2018~~ ~~October 2019~~. Originally approved in 1936. Last previous edition approved in ~~2015~~ ~~2018~~ as ~~B108/B108M – 15~~ ~~B108/B108M – 18<sup>e1</sup>~~. DOI: ~~10.1520/B0108\_B0108M-18E01~~ ~~10.1520/B0108\_B0108M-19~~.

<sup>2</sup> For ASME Boiler and Pressure Code application see related SB-108.

<sup>3</sup> For referenced ASTM standards, visit the ASTM website, [www.astm.org](http://www.astm.org), or contact ASTM Customer Service at [service@astm.org](mailto:service@astm.org). For *Annual Book of ASTM Standards* volume information, refer to the standard's Document Summary page on the ASTM website.

\*A Summary of Changes section appears at the end of this standard

TABLE 1 Chemical Composition Limits<sup>A,B,C,D</sup>

Desig. <sup>I</sup>	Si	Fe	Cu	Mn	Mg	Cr	Ni	Zn	Ti	Ag	Be	Pb	Sn	Zr	FNS	Others <sup>E</sup>		Al. Min
																Each	Total <sup>F</sup>	
204.0	0.20	0.35	4.2–5.0	0.10	0.15–0.35	...	0.05	0.10	0.15–0.30	...	...	...	0.05	...	...	0.05	0.15	Rem.
242.0	0.7	1.0	3.5–4.5	0.35	1.2–1.8	0.25	1.7–2.3	0.35	0.25	...	...	...	...	...	...	0.05	0.15	Rem.
296.0	2.0–3.0	1.2	4.0–5.0	0.35	0.05	...	0.35	0.50	0.25	...	...	...	...	...	...	...	0.35	Rem.
308.0	5.0–6.0	1.0	4.0–5.0	0.50	0.10	...	...	1.0	0.25	...	...	...	...	...	...	...	0.50	Rem.
319.0	5.5–6.5	1.0	3.0–4.0	0.50	0.10	...	0.35	1.0	0.25	...	...	...	...	...	...	...	0.50	Rem.
332.0 <sup>H</sup>	8.5–10.5	1.2	2.0–4.0	0.50	0.50–1.5	...	0.50	1.0	0.25	...	...	...	...	...	...	...	0.50	Rem.
333.0	8.0–10.0	1.0	3.0–4.0	0.50	0.05–0.50	...	0.50	1.0	0.25	...	...	...	...	...	...	...	0.50	Rem.
336.0 <sup>H</sup>	11.0–13.0	1.2	0.50–1.5	0.35	0.7–1.3	...	2.0–3.0	0.35	0.25	...	...	...	...	...	...	0.05	...	Rem.
354.0	8.6–9.4	0.20	1.6–2.0	0.10	0.40–0.6	...	...	0.10	0.20	...	...	...	...	...	...	0.05	0.15	Rem.
355.0	4.5–5.5	0.6 <sup>G</sup>	1.0–1.5	0.50 <sup>G</sup>	0.40–0.6	0.25	...	0.35	0.25	...	...	...	...	...	...	0.05	0.15	Rem.
C355.0	4.5–5.5	0.20	1.0–1.5	0.10	0.40–0.6	...	...	0.10	0.20	...	...	...	...	...	...	0.05	0.15	Rem.
356.0	6.5–7.5	0.6 <sup>G</sup>	0.25	0.35 <sup>G</sup>	0.20–0.45	...	...	0.35	0.25	...	...	...	...	...	...	0.05	0.15	Rem.
A356.0	6.5–7.5	0.20	0.20	0.10	0.25–0.45	...	...	0.10	0.20	...	...	...	...	...	...	0.05	0.15	Rem.
357.0	6.5–7.5	0.15	0.05	0.03	0.45–0.6	...	...	0.05	0.20	...	...	...	...	...	...	0.05	0.15	Rem.
A357.0	6.5–7.5	0.20	0.20	0.10	0.40–0.7	...	...	0.10	0.04–0.20	0.04–0.07	...	...	...	...	...	0.05	0.15	Rem.
E357.0	6.5–7.5	0.10	...	0.10	0.55–0.6	...	...	...	0.10–0.20	0.002	...	...	...	...	...	0.05	0.15	Rem.
F357.0	6.5–7.5	0.10	0.20	0.10	0.40–0.7	...	...	0.10	0.04–0.20	0.002	...	...	...	...	...	0.05	0.15	Rem.
359.0	8.5–9.5	0.20	0.20	0.10	0.50–0.7	...	...	0.10	0.20	...	...	...	...	...	...	0.05	0.15	Rem.
443.0	4.5–6.0	0.8	0.6	0.50	0.05	0.25	...	0.50	0.25	...	...	...	...	...	...	...	0.35	Rem.
B443.0	4.5–6.0	0.8	0.15	0.35	0.05	...	...	0.35	0.25	...	...	...	...	...	...	0.05	0.15	Rem.
A444.0	6.5–7.5	0.20	0.10	0.10	0.05	...	...	0.10	0.20	...	...	...	...	...	...	0.05	0.15	Rem.
513.0 <sup>H</sup>	0.30	0.40	0.10	0.30	3.5–4.5	...	...	1.4–2.2	0.20	...	...	...	...	...	...	0.05	0.15	Rem.
535.0	0.15	0.15	0.05	0.10–0.25	6.2–7.5	...	...	...	0.10–0.25	0.003–0.007	...	...	...	0.005B	...	0.05	.15	Rem.
705.0	0.20	0.8	0.20	0.40–0.6	1.4–1.8	0.20–0.40	...	2.7–3.3	0.25	...	...	...	...	...	...	0.05	.15	Rem.
707.0	0.20	0.8	0.20	0.40–0.6	1.8–2.4	0.20–0.40	...	4.0–4.5	0.25	...	...	...	...	...	...	0.05	.15	Rem.
711.0 <sup>H</sup>	0.30	0.7–1.4	0.35–0.6	0.05	0.25–0.45	...	...	6.0–7.0	0.20	...	...	...	...	...	...	0.05	.15	Rem.
713.0	0.25	1.1	0.40–1.0	0.6	0.20–0.50	0.35	0.15	7.0–8.0	0.25	...	...	...	...	...	...	0.10	0.25	Rem.
850.0	0.7	0.7	0.7–1.3	0.10	0.10	...	0.7–1.3	0.20	...	...	...	...	5.5–7.0	...	...	...	0.30	Rem.
851.0 <sup>H</sup>	2.0–3.0	0.7	0.7–1.3	0.10	0.10	...	0.30–0.7	0.20	...	...	...	...	5.5–7.0	...	...	...	0.30	Rem.
852.0 <sup>H</sup>	0.40	0.7	1.7–2.3	0.10	0.6–0.9	...	0.9–1.5	...	0.20	...	...	...	5.5–7.0	...	...	...	0.30	Rem.

<sup>A</sup> When single units are shown, they indicate the maximum amounts permitted.

<sup>B</sup> Analysis shall be made for the elements for which limits are shown in this table.

<sup>C</sup> The following applies to all specified limits in this table: For purposes of determining conformance to these limits, an observed value or a calculated value obtained from analysis shall be rounded to the nearest unit in the last right-hand place of figures used in expressing the specified limit in accordance with the rounding-off method of Practice E29.

<sup>D</sup> In case of discrepancy between the values listed in Table 1 and those listed in the "Designations and Chemical Composition Limits for Aluminum Alloys in the Form of Castings and Ingot ('The Pink Sheets')" the composition limits registered with the Aluminum Association and published in the "Pink Sheets" shall be considered the controlling composition.

<sup>E</sup> "Others" includes listed elements for which no specific limit is shown as well as unlisted metallic elements. The producer may analyze samples for trace elements not specified in the registration or specification. However, such analysis is not required and may not cover all metallic "others" elements. Should any analysis by the producer or the purchaser establish that an "others" element exceeds the limit of "Each" or that the aggregate of several "others" elements exceeds the limit of "Total," the material shall be considered nonconforming.

<sup>F</sup> The sum of those "Others" metallic elements 0.010 percent or more each, expressed to the second decimal before determining the sum.

<sup>G</sup> If iron exceeds 0.45, manganese content shall not be less than one-half iron content.

<sup>H</sup> 336.0 formerly A332.0, 332.0 formerly F332.0, 513.0 formerly A514.0, 711.0 formerly C712.0, 851.0 formerly A850.0, 852.0 for merly B850.0.

<sup>I</sup> For a cross reference of current and former alloy designations see the Aluminum Association's "Designations and Chemical Composition Limits for Aluminum Alloys in the Form of Castings and Ingot ('The Pink Sheets')."



- D3951 Practice for Commercial Packaging
- E29 Practice for Using Significant Digits in Test Data to Determine Conformance with Specifications
- E34 Test Methods for Chemical Analysis of Aluminum and Aluminum-Base Alloys (Withdrawn 2017)<sup>4</sup>
- E94/E94M Guide for Radiographic Examination Using Industrial Radiographic Film
- E155 Reference Radiographs for Inspection of Aluminum and Magnesium Castings
- E165/E165M Practice for Liquid Penetrant Testing for General Industry
- E607 Test Method for Atomic Emission Spectrometric Analysis Aluminum Alloys by the Point to Plane Technique Nitrogen Atmosphere (Withdrawn 2011)<sup>4</sup>
- E716 Practices for Sampling and Sample Preparation of Aluminum and Aluminum Alloys for Determination of Chemical Composition by Spark Atomic Emission Spectrometry
- E1251 Test Method for Analysis of Aluminum and Aluminum Alloys by Spark Atomic Emission Spectrometry
- E2422 Digital Reference Images for Inspection of Aluminum Castings
- IEEE/ASTM SI 10 Standard for Use of the International System of Units (SI): The Modern Metric System
- 2.3 *ANSI Standard:*<sup>5</sup>
  - H35.1/H35.1(M) Alloy and Temper Designation Systems for Aluminum
- 2.4 *Military Standards:*<sup>6</sup>
  - MIL-STD-129 Marking for Shipment and Storage
  - MIL-STD-276 Impregnation of Porous Nonferrous Metal Castings
  - NAVSEA S9074-AR-GIB-010/278 Requirements for Fabrication Welding and Inspection, and Casting Inspection and Repair for Machinery, Piping, and Pressure Vessels
- 2.5 *AMS Specification:*
  - AMS 2771 Heat Treatment of Aluminum Alloy Castings<sup>7</sup>
- 2.6 *Federal Standard:*<sup>6</sup>
  - Fed Std. No. 123 Marking for Shipment (Civil Agencies)
- 2.7 *Aluminum Association Standard:*<sup>5</sup>
  - Designations and Chemical Composition Limits for Aluminum Alloys in the Form of Castings and Ingot (The Pink Sheets)
- 2.8 *Other Standards:*<sup>8</sup>
  - CEN EN 14242 Aluminum and Aluminum Alloys, Chemical Analysis, Inductively Coupled Plasma Optical Emission Spectral Analysis

### 3. Terminology

- 3.1 *Definitions*—Refer to Terminology B881 for definitions of product terms used in this specification.

### 4. Ordering Information

- 4.1 Orders for material under this specification shall include the following information (see 1.4 and 1.5):
  - 4.1.1 This specification designation (which includes the number, the year, and the revision letter, if applicable),

NOTE 1—For inch-pound application, specify Specification B108 and for metric application specify Specification B108M. Do not mix units.

- 4.1.2 Alloy (see Section 7 and Table 1),
- 4.1.3 Temper (see Section 10 and Table 2 [Table 3]),
- 4.1.4 Applicable drawing or part number, and
- 4.1.5 The quantity in either pieces or pounds [kilograms].
- 4.2 Additionally, orders for material to this specification shall include the following information when required by the purchaser.
  - 4.2.1 Whether foundry control is required (see Section 9),
  - 4.2.2 Whether yield strength tests are required (see 10.1 and Table 2, Footnote C, [Table 4, Footnote D]),
  - 4.2.3 Whether castings or test bars, or both, are to be artificially aged for Alloys 705.0-T5, 707.0-T5, and 713.0-T5 (see 10.3),
  - 4.2.4 Whether test specimens cut from castings are required in addition to or instead of separately cast specimens (see Sections 10, 12.2, 13.2, and 15),
  - 4.2.5 Whether heat treatment is to be performed in accordance with AMS 2771 (see Section 16),
  - 4.2.6 Whether repairs are permissible (see Section 17),
  - 4.2.7 Whether inspection is required at the producer's works (see Section 18),
  - 4.2.8 Whether certification is required (see Section 22),

<sup>4</sup> The last approved version of this historical standard is referenced on [www.astm.org](http://www.astm.org).

<sup>5</sup> Available from Aluminum Association, Inc., 1400 Crystal Drive Suite 430 Arlington, VA 22202 <http://www.aluminum.org>.

<sup>6</sup> Available from Standardization Documents Order Desk, DODSSP, Bldg. 4, Section D, 700 Robbins Ave., Philadelphia, PA 19111-5098, <http://www.dodssp.daps.mil>.

<sup>7</sup> Available from Society of Automotive Engineers (SAE), 400 Commonwealth Dr., Warrendale, PA 15096-0001, <http://www.sae.org>.

<sup>8</sup> Available from European Committee for Standardization (CEN), 36 Rue de Stassart, B-1050, Brussels, Belgium, <http://www.cenorm.be>.

TABLE 2 Tensile Requirements<sup>A,B</sup> (Inch-Pound Units)

Designation <sup>F</sup>	Temper <sup>C</sup>	Tensile Strength, min, ksi	Yield Strength <sup>D</sup> (0.2 % offset), min, ksi (MPa)	Elongation in 2 in. or 4x diameter, min, %	Typical Brinell Hardness, <sup>E</sup> 500 kgf, 10 mm
204.0	T4 separately cast specimens	48.0	29.0	8.0	...
242.0	T571	34.0	...	<sup>G</sup>	105
	T61	40.0	...	<sup>G</sup>	110
296.0	T4	33.0	15.0	4.5	75
	T6	35.0	...	2.0	90
	T7	33.0	16.0	3.0	...
308.0	F	24.0	...	...	70
319.0	F	27.0	14.0	2.5	95
332.0 <sup>H</sup>	T5	31.0	...	<sup>G</sup>	105
333.0	F	28.0	...	<sup>G</sup>	90
	T5	30.0	...	<sup>G</sup>	100
	T6	35.0	...	<sup>G</sup>	105
	T7	31.0	...	<sup>G</sup>	90
336.0 <sup>H</sup>	T551	31.0	...	<sup>G</sup>	105
	T65	40.0	...	<sup>G</sup>	125
354.0	T61				
	separately cast specimens	48.0	37.0	3.0	
	casting, designated area <sup>I</sup>	47.0	36.0	3.0	
	castings, no location designated <sup>I</sup>	43.0	33.0	2.0	
	T62				
	separately cast specimens	52.0	42.0	2.0	
	castings, designated area <sup>I</sup>	50.0	42.0	2.0	
	castings, no location designated <sup>I</sup>	43.0	33.0	2.0	
355.0	T51	27.0	...	<sup>G</sup>	75
	T62	42.0	...	<sup>G</sup>	105
	T7	36.0	...	<sup>G</sup>	90
	T71	34.0	27.0	<sup>G</sup>	80
C355.0	T61				
	separately cast specimens	40.0	30.0	3.0	85–90
	castings, designated area <sup>I</sup>	40.0	30.0	3.0	
	castings, no location designated <sup>I</sup>	37.0	30.0	1.0	85
356.0	F	21.0	10.0	3.0	
	T6	33.0	22.0	3.0	85
	T71	25.0	...	3.0	70
A356.0	T61				
	separately cast specimens	38.0	26.0	5.0	80–90
	castings, designated area <sup>I</sup>	33.0	26.0	5.0	
	castings, no location designated <sup>I</sup>	28.0	26.0	3.0	
357.0	T6	45.0	...	3.0	...
A357.0	T61				
	separately cast specimens	45.0	36.0	3.0	100
	castings, designated area <sup>I</sup>	46.0	36.0	3.0	
	castings, no location designated <sup>I</sup>	41.0	31.0	3.0	
E357.0 <sup>J</sup>	T61				
	separately cast specimens	45.0	36.0	3.0	100
	castings, designated area <sup>I</sup>	46.0	36.0	3.0	
	castings, no location designated <sup>I</sup>	41.0	31.0	3.0	
F357.0 <sup>K</sup>	T6	45.0	...	3.0	
359.0	T61				
	separately cast specimens	45.0	34.0	4.0	90
	castings, designated area <sup>I</sup>	45.0	34.0	4.0	
	castings, no location designated <sup>I</sup>	40.0	30.0	3.0	
	T62				
	separately cast specimens	47.0	38.0	3.0	100
	castings, designated area <sup>I</sup>	47.0	38.0	3.0	
	castings, no location designated <sup>I</sup>	40.0	30.0	3.0	
443.0	F	21.0	7.0	2.0	45
B443.0	F	21.0	6.0	2.5	45
A444.0	T4				
	separately cast specimens	20.0	...	20	...
	castings, designated area <sup>I</sup>	20.0	...	20	...
513.0 <sup>H</sup>	F	22.0	12.0	2.5	60
535.0	F	35.0	18.0	8.0	...
705.0	T1 or T5	37.0	17.0	10.0	
707.0	T1	42.0	25.0	4.0	
	T7	45.0	35.0	3.0	
711.0 <sup>H</sup>	T1	28.0	18.0	7.0	70
713.0	T1 or T5	32.0	22.0	4.0	
850.0	T5	18.0	...	8.0	
851.0 <sup>H</sup>	T5	17.0	...	3.0	
	T6	18.0	...	8.0	
852.0 <sup>H</sup>	T5	27.0	...	3.0	



- <sup>A</sup> If agreed upon by manufacturer and the purchaser, other mechanical properties may be obtained by other heat treatments such as annealing, aging, or stress relieving.
- <sup>B</sup> For purposes of determining conformance with this specification, each value for tensile strength and yield strength shall be rounded to the nearest 0.1 ksi, and each value for elongation shall be rounded to the nearest 0.5 %, both in accordance with the rounding method of Practice E29.
- <sup>C</sup> Refer to ANSI H 35.1/H35.1(M) for description of tempers.
- <sup>D</sup> Yield strength to be evaluated only when specified in contract or purchase order.
- <sup>E</sup> Hardness values given for information only, not required for acceptance.
- <sup>F</sup> ASTM alloy designations are recorded in Practice B275.
- <sup>G</sup> Not required.
- <sup>H</sup> 332.0 formerly F332.0, 336.0 formerly A332.0, 513.0 formerly A514.0, 711.0 formerly C712.0, 851.0 formerly A850.0, 852.0 formerly B850.0.
- <sup>I</sup> These properties apply only to castings having section thicknesses not greater than 2 in. except that section thicknesses of ¾ in., max, shall apply to Alloy A444.0.
- <sup>J</sup> Properties copied from A357.0–T61.
- <sup>K</sup> Properties copied from 357.0–T6.

4.2.9 Whether surface requirements will be checked visually or by observational standards where such standards are established (see 19.1),

4.2.10 Whether liquid penetrant inspection is required (see 19.2),

4.2.11 Whether radiographic inspection is required and, if so, the radiographic grade of casting required (19.3, Table 4), and

4.2.12 Whether Practices B660 applies and, if so, the levels of preservation, packaging, and packing required (see 24.4).

## 5. Responsibility for Quality Assurance

5.1 Unless otherwise specified in the contract or purchase order, the producer shall be responsible for the performance of all inspections and test requirements specified herein. Unless otherwise agreed upon, the producer may use his own or any other suitable facilities for the performance of the inspection and test requirements specified herein. The purchaser shall have the right to perform any of the inspections and tests set forth in the specification where such inspections are deemed necessary to confirm that the material conforms to prescribed requirements.

## 6. Manufacture

6.1 The responsibility of furnishing castings that can be laid out and machined to the finished dimensions within the permissible variations specified, as shown on the blueprints or drawings, shall rest with the producer, except where mold equipment is furnished by the purchaser.

## 7. Chemical Composition

7.1 The product shall conform to the chemical composition limits prescribed in Table 1. Conformance shall be determined by the producer by taking samples at the time castings are poured in accordance with Practice E716 and analyzed in accordance with Test Methods E34, E607, or E1251, or CEN EN 14242. If the producer has determined the composition of the material during casting, they shall not be required to sample and analyze the finished product.

7.1.1 A sample for determination of chemical composition shall be taken to represent one of the following:

7.1.2 Not more than 4000 lb [2000 kg] of clean castings or a single casting poured from one furnace. The maximum elapsed time between determinations shall be established for each alloy, but in any case the maximum elapsed time shall not exceed 8 h.

7.1.3 The maximum elapsed time between determinations shall be established for each alloy, but in any case the maximum elapsed time shall not exceed 8 h.

7.2 If it becomes necessary to analyze castings for conformance to chemical composition limits, the method used to sample castings for the determination of chemical composition shall be accordance with Practice B985. Analysis shall be performed in accordance with Practice E716, Test Methods E34, E607, or E1251, or CEN EN 14242 (ICP method).

## 8. Material Requirements—Castings Produced for Governmental and Military Agencies

8.1 Unless otherwise specified, only aluminum alloy conforming to the requirements of Specification B179 or producers foundry scrap, identified as being made from alloy conforming to Specification B179, shall be used in the remelting furnace from which molten metal is taken for pouring directly into castings. Additions of small amounts of modifying and grain refining elements or alloys are permitted.

8.2 Pure materials, recycled materials, and master alloys may be used to make alloys conforming to this specification, provided chemical analysis can be taken and adjusted to conform to Table 1 prior to pouring any castings.

## 9. Foundry Control—Castings Produced for Governmental or Military Agencies, or Both

9.1 When specified, castings shall be produced under foundry control approved by the purchaser. Foundry control shall consist of examination of castings by radiographic or other approved methods for determining internal discontinuities until the gating, pouring, and other foundry practices have been established to produce castings meeting the quality standards furnished by the purchaser or agreed upon between the purchaser and the producer. When foundry practices have been so established, the production

TABLE 3 Tensile Requirements (SI Units)—[Metric]<sup>A,B,C</sup>

Designation <sup>H</sup>	Temper <sup>D</sup>	Tensile Strength, min, MPa <sup>E</sup>	Yield Strength <sup>F</sup> (0.2 % offset), min, MPa <sup>E</sup>	Elongation in 5D, min, %	Typical Brinell Hardness <sup>G</sup> 500-kgf load, 10-mm ball
204.0	T4 separately cast specimens	330	200	7.0	...
242.0	T571	235	...	/	105
	T61	275	...	/	110
296.0	T4	230	105	4.5	75
	T6	240	...	2.0	90
	T7	230	110	3.0	...
308.0	F	165	...	...	70
319.0	F	185	95	2.5	95
332.0 <sup>J</sup>	T5	215	...	/	105
333.0	F	195	...	/	90
	T5	205	...	/	100
	T6	240	...	/	105
	T7	215	...	/	90
336.0 <sup>J</sup>	T551	215	...	/	105
	T65	275	...	/	125
354.0	T61				
	separately cast specimens	330	255	3.0	
	castings, designated area <sup>K</sup>	325	250	3.0	
	castings, no location designated <sup>K</sup>	295	230	2.0	
	T62				
	separately cast specimens	360	290	2.0	
	castings, designated area <sup>K</sup>	345	290	2.0	
	castings, no location designated <sup>K</sup>	295	230	2.0	
355.0	T51	185	...	/	75
	T62	290	...	/	105
	T7	250	...	/	90
	T71	235	185	/	80
C355.0	T61				
	separately cast specimens	275	205	3.0	85–90
	castings, designated area <sup>K</sup>	275	205	3.0	
	castings, no location designated <sup>K</sup>	255	205	1.0	85
356.0	F	145	70	3.0	
	T6	230	150	3.0	85
	T71	170	...	3.0	70
A356.0	T61				
	separately cast specimens	260	180	4.0	80–90
	castings, designated area <sup>K</sup>	230	180	4.0	
	castings, no location designated <sup>K</sup>	195	180	3.0	
357.0	T6	310	...	3.0	...
A357.0	T61				
	separately cast specimens	310	250	3.0	100
	castings, designated area <sup>K</sup>	315	250	3.0	...
	castings, no location designated <sup>K</sup>	285	215	3.0	...
E357.0 <sup>L</sup>	T61				
	separately cast specimens	310	250	3.0	100
	castings, designated area <sup>K</sup>	315	250	3.0	
	castings, no location designated <sup>K</sup>	285	215	3.0	
F357.0 <sup>M</sup>	T6	310	...	3.0	
359.0	T61				
	separately cast specimens	310	235	4.0	90
	castings, designated area <sup>K</sup>	310	235	4.0	
	castings, no location designated <sup>K</sup>	275	205	3.0	
	T62				
	separately cast specimens	325	260	3.0	100
	castings, designated area <sup>K</sup>	325	260	3.0	
	castings, no location designated <sup>K</sup>	275	205	3.0	
443.0	F	145	50	2.0	45
B443.0	F	145	40	2.5	45
A444.0	T4				
	separately cast specimens	140	...	18.0	...
	castings, designated area <sup>K</sup>	140	...	18.0	...
513.0 <sup>J</sup>	F	150	80	2.5	60
535.0	F	240	125	7.0	...
705.0	T1 or T5	255	115	9.0	
707.0	T1	290	170	4.0	
	T7	310	240	3.0	
711.0 <sup>J</sup>	T1	195	125	6.0	70
713.0	T1 or T5	220	150	4.0	
850.0	T5	125	...	7.0	
851.0 <sup>J</sup>	T5	115	...	3.0	
	T6	125	...	7.0	
852.0 <sup>J</sup>	T5	185	...	3.0	



- <sup>A</sup> If agreed upon by manufacturer and the purchaser, other mechanical properties may be obtained by other heat treatments such as annealing, aging, or stress relieving.
- <sup>B</sup> For purposes of determining conformance with this specification, each value for tensile strength and yield strength shall be rounded to the nearest 1 MPa and each value for elongation shall be rounded to the nearest 0.5 %, both in accordance with the rounding method of Practice E29.
- <sup>C</sup> Guidelines for metric conversion from the "Tempers for Aluminum and Aluminum Alloys, Metric Edition ("Tan Sheets")," Appendix A, were used to convert the tensile and yield values to SI units.<sup>6</sup>
- <sup>D</sup> Refer to ANSI H 35.1/H35.1(M) for description of tempers.
- <sup>E</sup> For explanation of the SI Unit "MPa" see Appendix X2.
- <sup>F</sup> Yield strength to be evaluated only when specified in contract or purchase order.
- <sup>G</sup> Hardness values given for information only, not required for acceptance.
- <sup>H</sup> ASTM alloy designations are recorded in Practice B275.
- <sup>I</sup> Not required.
- <sup>J</sup> 332.0 formerly F332.0, 336.0 formerly A332.0, 513.0 formerly A514.0, 711.0 formerly C712.0, 851.0 formerly A850.0, 852.0 formerly B850.0.
- <sup>K</sup> These properties apply only to castings having section thicknesses not greater than 2 in. except that section thicknesses of 19-mm max, shall apply to Alloy A444.0.
- <sup>L</sup> Properties copied from A357.0–T61.
- <sup>M</sup> Properties copied from 357.0–T6.

TABLE 4 Discontinuity—Level Requirements for Aluminum Castings in Accordance with Film Reference Radiographs E155 or Digital Reference Radiographs E2422

Discontinuity	Grade A <sup>A</sup>	Grade B		Grade C		Grade D		
	Section Thickness, in. (mm)							
	1/4 to 3/4 (6.4 to 19.0)	1/4 (6.4)	3/4 (19.0)	1/4 (6.4)	3/4 (19.0)	1/4 (6.4)	3/4 (19.0)	
Gas holes	none	1	1	2	2	5	5	
Gas porosity (round)	none	1	1	3	3	7	7	
Gas porosity (elongated)	none	1	1	3	4	5	5	
Shrinkage cavity	none	1	<sup>B</sup>	2	<sup>B</sup>	3	<sup>B</sup>	
Shrinkage porosity or sponge	none	1	1	2	2	4	3	
Foreign material (less dense material)	none	1	1	2	2	4	4	
Foreign material (more dense material)	none	1	1	2	1	4	3	
Segregation	none		none		none		none	
Cracks	none		none		none		none	
Cold shuts	none		none		none		none	
Surface irregularity			not to exceed drawing tolerance					
Core shaft			not to exceed drawing tolerance					

<sup>A</sup> Caution should be exercised in requesting grade A because of the difficulty in obtaining this level.

<sup>B</sup> No radiographs available. Use 1/4-in. [6-mm] for all thicknesses.

method shall not be significantly changed without demonstrating to the satisfaction of the purchaser that the change does not adversely affect the quality of the castings. Minor changes in pouring temperature of ±50°F [±28°C] from the established nominal temperature are permissible.

### 10. Tensile Requirements

10.1 The separately cast tension test specimens representing the castings shall meet the mechanical properties prescribed in Table 2 [Table 3].

10.2 When specified, the tensile strength and elongation of test specimens cut from castings shall be in accordance with Table 2 [Table 3] for Alloys 354.0, C355.0, A356.0, A357.0, E357.0, 359.0, and A444.0. For other alloys a minimum of 75 % of the tensile and yield strength values and not less than 25 % of the elongation values specified in Table 2 [Table 3] are required. The measurement of elongation is not required for test specimens cut from castings if 25 % of the specified minimum elongation value published in Table 2 [Table 3] is 0.5 % or less. If grade D quality castings as described in Table 4 are specified, no tensile tests shall be specified nor tensile requirements be met on specimens cut from castings.

10.3 Although Alloys 705.0, 707.0, and 713.0 are most frequently used in the naturally aged condition, by agreement of the producer and the purchaser, the castings may be artificially aged. The producer and the purchaser may also agree to base the acceptance of castings on artificially aged test bars. The conditions of artificial aging shown in Practice B917/B917M or AMS 2771 shall be employed unless other conditions are accepted by mutual consent.

### 11. Workmanship, Finish, and Appearance

11.1 The finished castings shall be uniform in composition and free of blowholes, cracks, shrinks, and other discontinuities in accordance with standards designated and agreed upon as acceptable by the purchaser.

### 12. Test Specimens

12.1 Separately cast test specimens shall be cast in iron molds. A recommended gating method is shown in Fig. 1 [Fig. 2] and Fig. 3 [Fig. 4]. An alternative gating design is shown in Appendix X4. The test section of the tension test specimen shall be cast

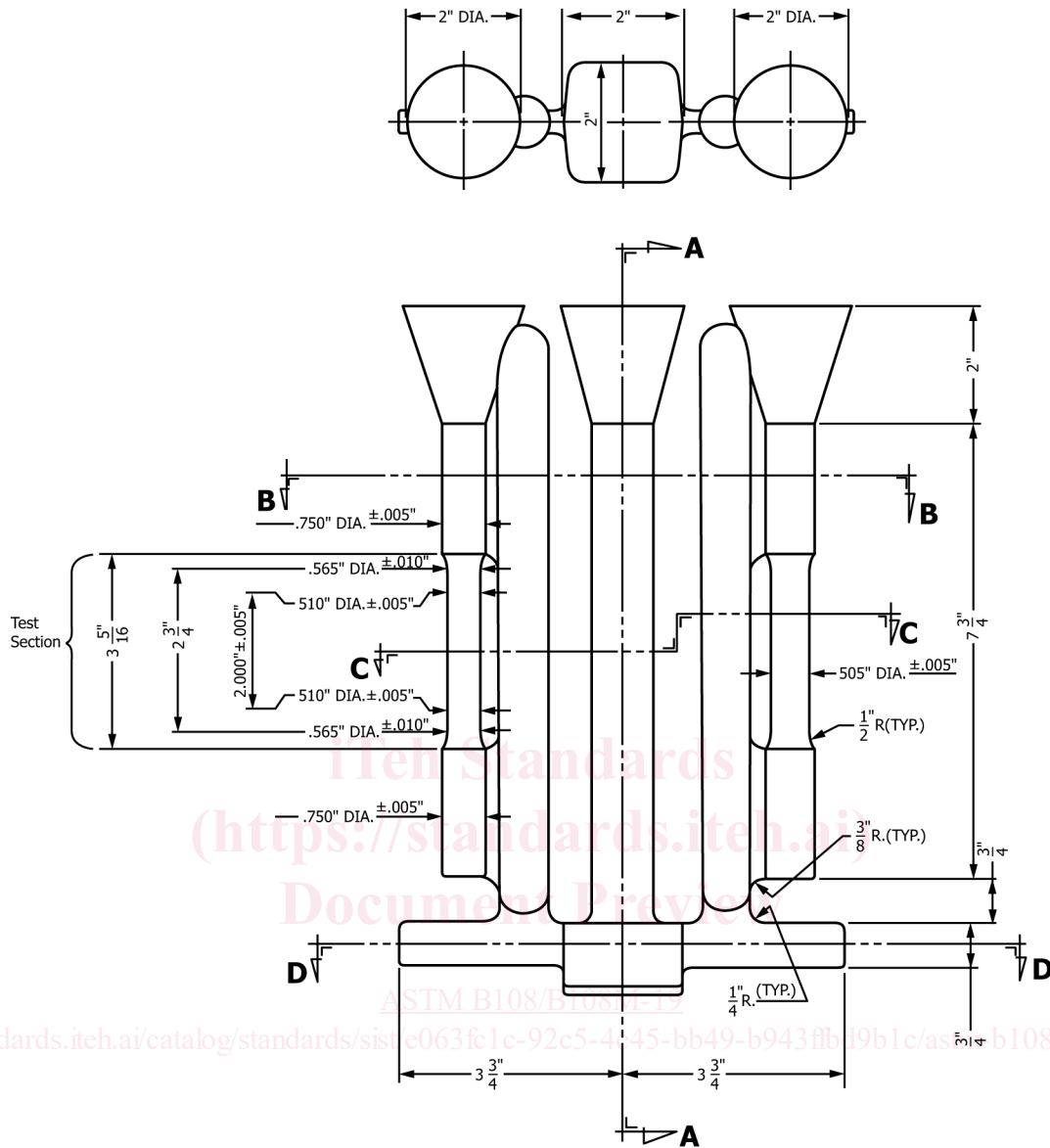

Nominal draft angle to be 20° on all square or rectangular sections in direction transverse to parting line.

NOTE 1—Test section of test bar: this section to be gradually tapered from the ends towards the center.

**FIG. 1 Tension Test Specimen Casting (Inch-Pounds)**

to size in accordance with the dimensions shown in Fig. 1 [Fig. 2] and Fig. 3 [Fig. 4], and not machined prior to test. Grip ends may be machined to adapt them in such a manner as to ensure axial loading.

12.2 When properties of castings are to be determined, tension test specimens shall be cut from the locations designated on the drawings, unless otherwise negotiated. If no locations are designated, one or more specimens shall be taken to include locations having significant variation in casting thickness, except that specimens shall not be taken from areas directly under risers. The tension test specimens shall be the standard 0.500-in. [12.5 mm] diameter specimens shown in Fig. 9 of Test Methods B557 [B557M] or a round specimen of smaller size proportional to the standard specimens. In no case shall the dimensions of the smallest specimen be less than the following:

	in.	mm
Diameter of reduced section.	0.250	[6.00]
Length of reduced section	1/4	[32]
Radius of fillet	3/16	[5]
Diameter of end section	3/8	[10]
Overall length:		
With shouldered ends	2 3/8	[60]
With threaded ends	3	[75]
With plain cylindrical ends	4	[100]



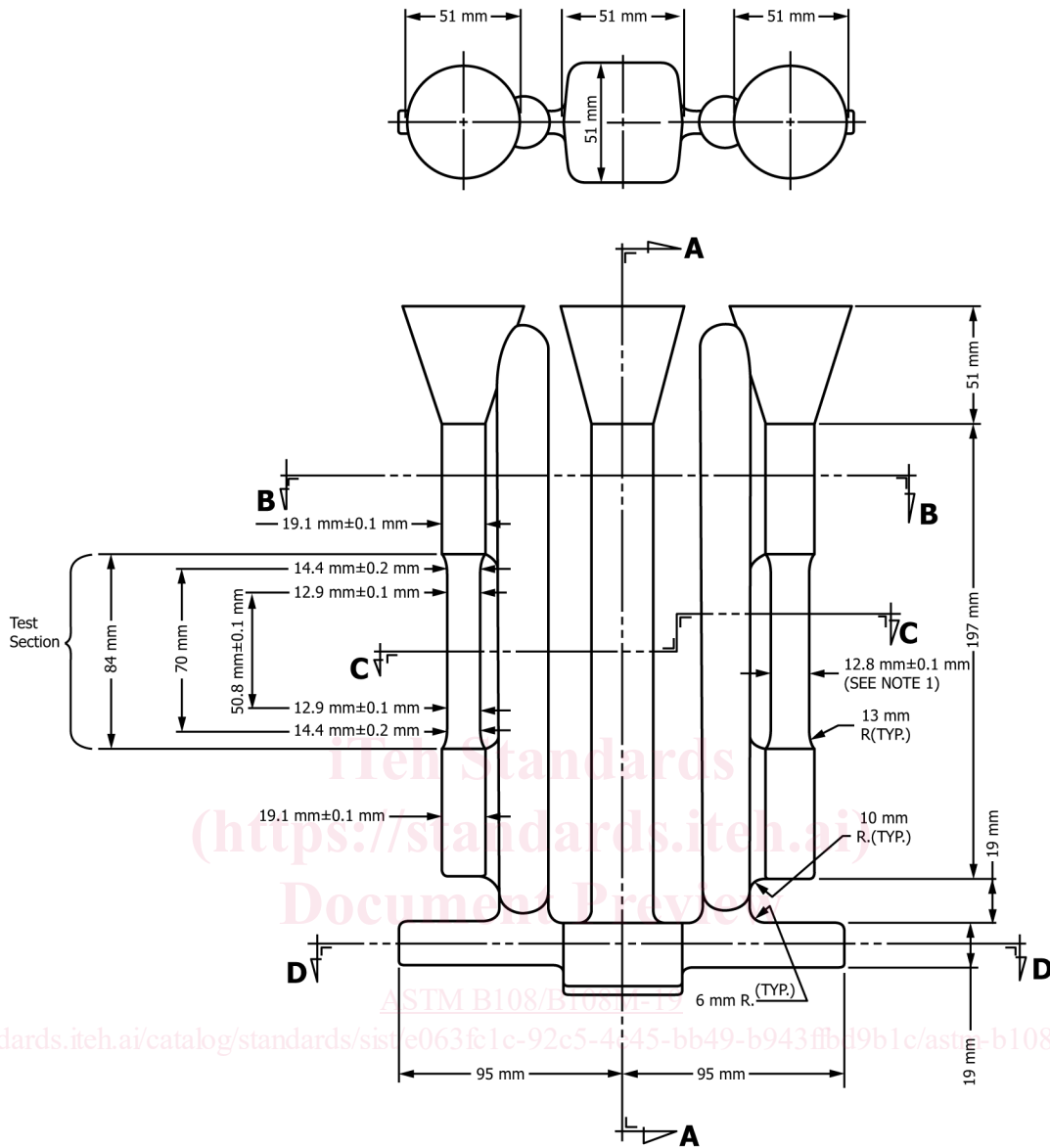

Nominal draft angle to be 20° on all square or rectangular sections in direction transverse to parting line.

NOTE 1—Test section of test bar: this section to be gradually tapered from the ends towards the center.

**FIG. 2 Tension Test Specimen Casting [Metric]**

12.3 When necessary, a rectangular specimen may be used proportional to that shown for the 0.500 in. [12.5 mm] wide specimen in Fig. 6 of Test Methods B557 [B557M], but in no case shall its dimensions be less than the following:

	in.	mm
Width of reduced section,	¼	[6]
Length of reduced section,	1¼	[32]
Radius of fillet,	¼	[6]
Overall length,	4	[100]

The specified elongation values shall not apply to tests of rectangular specimens.

12.4 If the castings are to be heat treated and separately cast specimens are to be used, the specimens representing such castings shall be heat treated with the castings they represent. If castings are to be heat treated and tests are to be obtained on the castings, the test specimens shall be taken from the castings after heat treatment.

### 13. Number of Tests

13.1 Unless otherwise agreed upon by the purchaser and producer, two tension test specimens shall be separately cast and tested to represent the following:

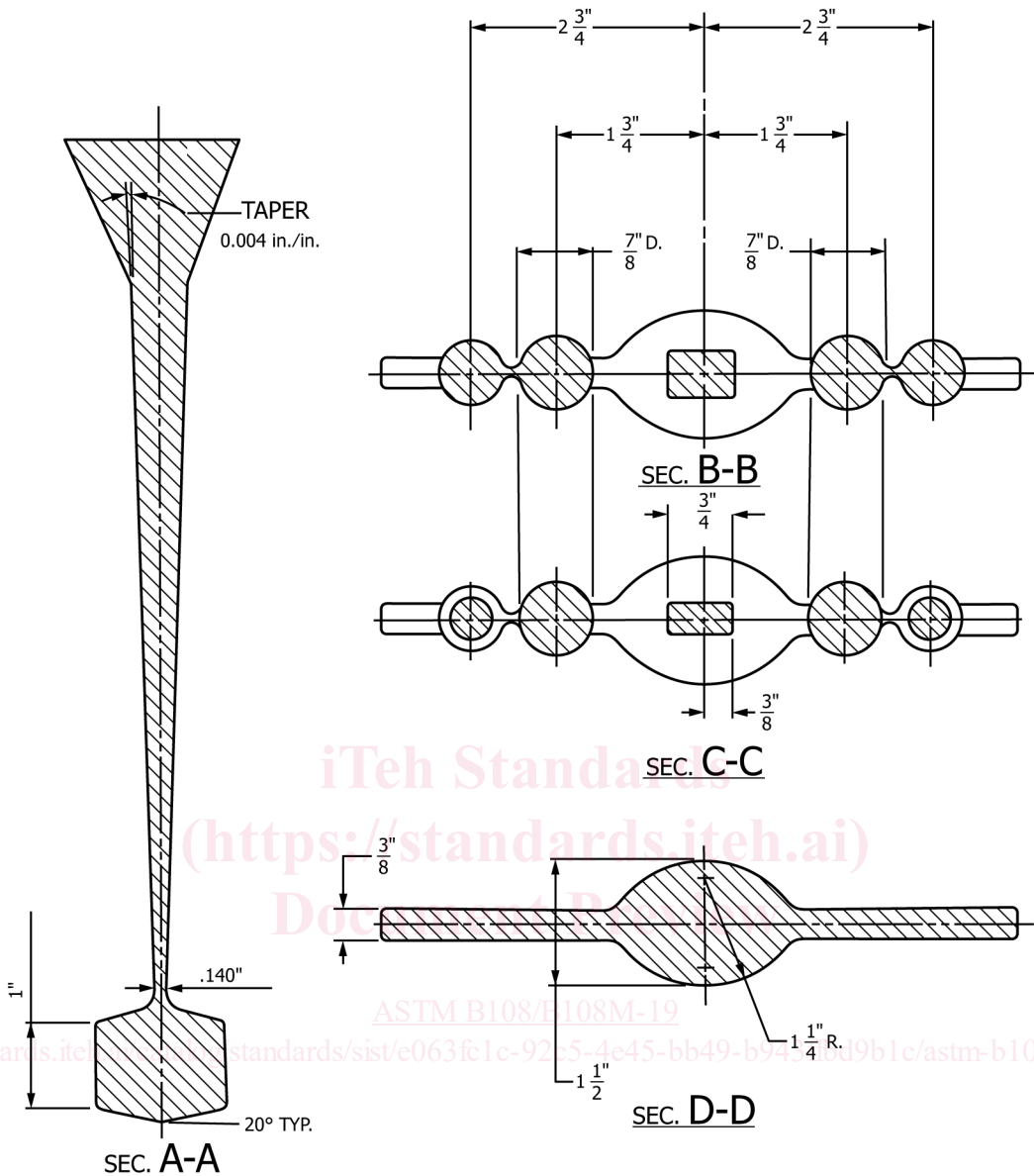

FIG. 3 Tension Test Specimen Casting (Cross Section) (Inch-Pounds)

- 13.1.1 Not more than 4000 lb [2000 kg] of clean castings (gates and risers removed) or a single casting poured from one furnace.
- 13.1.2 The castings poured continuously from one furnace in not more than eight consecutive hours.

13.2 When tensile properties of castings are to be determined, one per melt-heat combination shall be tested unless otherwise shown on the drawing or specified in the purchase order.

13.3 If any test specimen shows defective machining or flaws, it may be discarded, in which case the purchaser and the producer shall agree upon the selection of a replacement specimen.

#### 14. Test Methods

- 14.1 The tensile properties shall be determined in accordance with Test Methods B557 [B557M].

#### 15. Retests

15.1 If the results of the tension test do not conform to the requirements prescribed in Table 2 [Table 4], test bars representative of the castings may be retested in accordance with the replacement tests and retest provisions of Test Methods B557 [B557M] and the results of retests shall conform to the requirements as to mechanical properties specified in Table 2 [Table 4].