



Designation: D1816 – 12 (Reapproved 2019)

# Standard Test Method for Dielectric Breakdown Voltage of Insulating Liquids Using VDE Electrodes<sup>1</sup>

This standard is issued under the fixed designation D1816; the number immediately following the designation indicates the year of original adoption or, in the case of revision, the year of last revision. A number in parentheses indicates the year of last reapproval. A superscript epsilon ( $\epsilon$ ) indicates an editorial change since the last revision or reapproval.

## 1. Scope\*

1.1 This test method covers the determination of the dielectric breakdown voltage of insulating liquids (oils of petroleum origin, silicone fluids, high fire-point mineral electrical insulating oils, synthetic ester fluids and natural ester fluids). This test method is applicable to insulating liquids commonly used in cables, transformers, oil circuit breakers, and similar apparatus as an insulating and cooling medium. Refer to Terminology [D2864](#) for definitions used in this test method.

1.2 This test method is sensitive to the deleterious effects of moisture in solution especially when cellulosic fibers are present in the liquid. It has been found to be especially useful in diagnostic and laboratory investigations of the dielectric breakdown strength of insulating liquid in insulating systems.<sup>2</sup>

1.3 This test method is used to judge if the VDE electrode breakdown voltage requirements are met for insulating liquids. This test method should be used as recommended by professional organization standards such as IEEE C57.106.

1.4 This test method may be used to obtain the dielectric breakdown of silicone fluid as specified in Test Method [D2225](#), Specification [D4652](#), or Specification [D6871](#), provided that the discharge energy into the sample is less than 20 mJ (milli joule) per breakdown for five consecutive breakdowns.

1.5 Both the metric and the alternative inch-pound units are acceptable.

1.6 *This standard does not purport to address all of the safety concerns, if any, associated with its use. It is the responsibility of the user of this standard to establish appropriate safety, health, and environmental practices and determine the applicability of regulatory limitations prior to use.*

1.7 *This international standard was developed in accordance with internationally recognized principles on standardization established in the Decision on Principles for the*

<sup>1</sup> This test method is under the jurisdiction of ASTM Committee [D27](#) on Electrical Insulating Liquids and Gases and is the direct responsibility of Subcommittee [D27.05](#) on Electrical Test.

Current edition approved Oct. 1, 2019. Published October 2019. Originally approved in 1960 as D1816 – 60 T. Last previous edition approved in 2012 as D1816 – 12. DOI: 10.1520/D1816-12R19.

<sup>2</sup> Supporting data is available from ASTM Headquarters. Request RR:D27-1006.

*Development of International Standards, Guides and Recommendations issued by the World Trade Organization Technical Barriers to Trade (TBT) Committee.*

## 2. Referenced Documents

### 2.1 ASTM Standards:<sup>3</sup>

[D235](#) Specification for Mineral Spirits (Petroleum Spirits) (Hydrocarbon Dry Cleaning Solvent)

[D923](#) Practices for Sampling Electrical Insulating Liquids

[D2225](#) Test Methods for Silicone Fluids Used for Electrical Insulation

[D2864](#) Terminology Relating to Electrical Insulating Liquids and Gases

[D3487](#) Specification for Mineral Insulating Oil Used in Electrical Apparatus

[D4652](#) Specification for Silicone Fluid Used for Electrical Insulation

[D6871](#) Specification for Natural (Vegetable Oil) Ester Fluids Used in Electrical Apparatus

### 2.2 IEEE Standard:

[Standard 4](#) IEEE Standard Techniques for High Voltage Testing<sup>4</sup>

[C57.106](#) Guide for Acceptance and Maintenance of Insulating Oil in Equipment<sup>4</sup>

## 3. Significance and Use

3.1 The dielectric breakdown voltage of an insulating liquid is of importance as a measure of the liquid's ability to withstand electric stress without failure. The dielectric breakdown voltage serves to indicate the presence of contaminating agents such as water, dirt, cellulosic fibers, or conducting particles in the liquid, one or more of which may be present in significant concentrations when low breakdown voltages are obtained. However, a high dielectric breakdown voltage does not necessarily indicate the absence of all contaminants; it may merely indicate that the concentrations of contaminants that are

<sup>3</sup> For referenced ASTM standards, visit the ASTM website, [www.astm.org](http://www.astm.org), or contact ASTM Customer Service at [service@astm.org](mailto:service@astm.org). For Annual Book of ASTM Standards volume information, refer to the standard's Document Summary page on the ASTM website.

<sup>4</sup> Available from the Institute of Electrical and Electronic Engineers, Inc., PO Box 1331, Piscataway, NJ 08855.

\*A Summary of Changes section appears at the end of this standard

present in the liquid between the electrodes are not large enough to deleteriously affect the average breakdown voltage of the liquid when tested by this test method (see Appendix X1.)

3.2 This test method is used in laboratory or field tests. For field breakdown results to be comparable to laboratory results, all criteria including room temperature (20 to 30 °C) must be met.

**4. Electrical Apparatus**

4.1 In addition to this section, use IEEE Standard 4 to determine other requirements necessary for conducting test measurements, and maintaining error limits using alternating voltages. Procedures to ensure accuracy should follow the requirements of IEEE Standard 4. Calibration(s) shall be traceable to national standards and calibration should be verified annually or more often to ensure accuracy requirements. IEEE Standard 4 is required during the manufacturing of the test apparatus and utilized during calibration of the equipment.

4.1.1 *Test Voltage*—The test voltage shall be an alternating voltage having a frequency in the range from 45 to 65 Hz, normally referred to as power-frequency voltage. The voltage wave shape should approximate a sinusoid with both half cycles closely alike, and it should have a ratio of peak-to-rms values equal to the square root of 2 within ±5 %.

4.1.2 *Generation of the Test Voltage*— The test voltage is generally supplied by a transformer or resonant circuit. The voltage in the test circuit should be stable enough to be unaffected by varying current flowing in the capacitive and resistive paths of the test circuit. Non-disruptive discharges in the test circuit should not reduce the test voltage to such an extent, and for such a time, that the disruptive discharge (breakdown) voltage of the test specimen is significantly affected. In the case of a transformer, the short-circuit current delivered by the transformer should be sufficient to maintain the test voltage within 3 % during transient current pulses or discharges, and a short circuit current of 0.1 A may suffice.

4.1.3 *Disruptive Voltage Measurement*— Design the measurement circuit so the voltage recorded at the breakdown is the maximum voltage across the test specimen immediately prior to the disruptive breakdown, with an error no greater than 3 %.

4.2 *Circuit-Interrupting Equipment*— Design the circuit used to interrupt the disruptive discharge through the specimen to operate when the voltage across the specimen has collapsed to less than 100 V. It is recommended that the circuit design limit the disruptive current duration and magnitude to low values that will minimize damage to the electrodes and limit formation of non-soluble materials resulting from the breakdown, but consistent with the requirements of 4.1.2, but in no case should the short-circuit current exceed 1 mA/kV of applied voltage.

4.3 *Voltage Control Equipment*—Use a rate of voltage rise of 0.5 kV/s. The tolerance of the rate of rise should be 5 % for any new equipment manufactured after the year 2000. Automatic equipment should be used to control the voltage rate of

rise because of the difficulty of maintaining a uniform voltage rise manually. The equipment should produce a straight-line voltage-time curve over the operating range of the equipment. Calibrate and label automatic controls in terms of rate-of-rise.

4.4 *Measuring Systems*—The voltage shall be measured by a method that fulfills the requirements of IEEE Standard No. 4, giving rms values.

4.5 Connect the electrode such that the voltage measured from each electrode with respect to ground during the test is equal within 5 %.

4.6 *Accuracy*—The combined accuracy of the voltmeter and voltage divider circuit shall be such that measurement error does not exceed 3 % at the rate-of-voltage rise specified in 4.3. For equipment manufactured prior to 1995 the maximum allowable error is 5 %.

**5. Electrodes**

5.1 The electrodes shall be polished brass spherically-capped electrodes of the VDE (Verband Deutscher Elektrotechniker, Specification 0370) type having the dimensions shown in Fig. 1 ±1 %, mounted with axes horizontal and coincident within ±1 mm.

**6. Test Cell**

6.1 The test cell shall be designed to permit easy removal of the electrodes for cleaning and polishing, verification that the shape is within the specified tolerance, and to permit easy adjustment of the gap spacing. The vector sum of the resistive and capacitive current of the cup, when filled with oil meeting the requirements of Specification D3487, shall be less than 200 µA at 20 kV, at power frequency. Mount the electrodes rigidly from opposite sides with the spacing axially centered within ±1 mm. Clearance from the electrodes to all sides, bottom, cover or baffle, and any part of the stirring device is at least

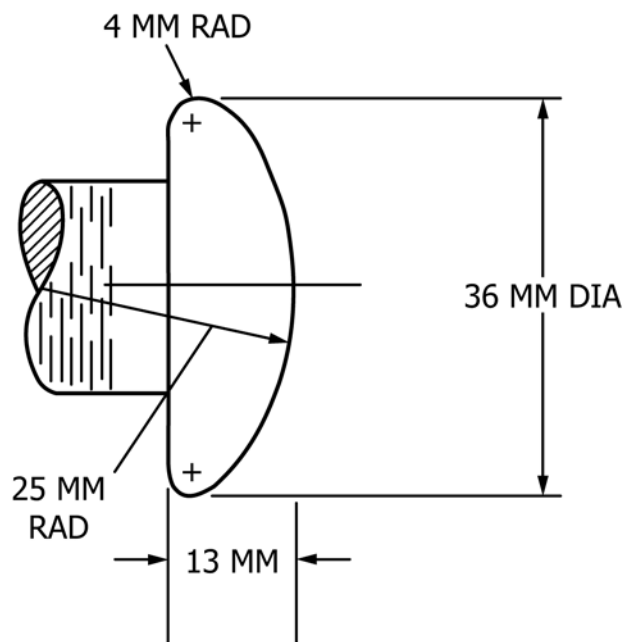

FIG. 1 VDE Electrode