



Designation: B956 – 19<sup>ε</sup>1

# Standard Specification for Welded Copper and Copper-Alloy Condenser and Heat Exchanger Tubes with Integral Fins<sup>1</sup>

This standard is issued under the fixed designation B956; the number immediately following the designation indicates the year of original adoption or, in the case of revision, the year of last revision. A number in parentheses indicates the year of last reapproval. A superscript epsilon ( $\epsilon$ ) indicates an editorial change since the last revision or reapproval.

<sup>ε</sup>1 NOTE—Footnote 1 was editorially corrected in November 2019.

## 1. Scope\*

1.1 This specification establishes the requirements for heat exchanger tubes manufactured from forge-welded copper and copper alloy tubing in straight lengths on which the external or internal surface, or both, has been modified by cold forming process to produce an integral enhanced surface for improved heat transfer.

1.2 The tubes are typically used in surface condensers, evaporators, and heat exchangers.

1.3 The product shall be produced of the following coppers or copper alloys, as specified in the ordering information.

Copper or Copper Alloy UNS No.	Type of Metal
C12000 <sup>A</sup>	DLP Phosphorized, low residual phosphorus
C12200 <sup>A</sup>	DHP Phosphorized, high residual phosphorus
C19200	Phosphorized, 1 % iron
C19400	Copper-Iron Alloy
C23000	Red Brass
C44300	Admiralty, arsenical
C44400	Admiralty, antimonial
C44500	Admiralty, phosphorized
C68700	Aluminum Brass
C70400	95-5 Copper-Nickel
C70600	90-10 Copper-Nickel
C70620	90-10 Copper-Nickel (Modified for Welding)
C71000	80-20 Copper-Nickel
C71500	70-30 Copper-Nickel
C71520	70-30 Copper-Nickel (Modified for Welding)
C72200	Copper-Nickel

<sup>A</sup> Copper UNS Nos. C12000 and C12200 are classified in Classification B224.

NOTE 1—Designations listed in Classification B224.

1.4 *Units*—The values stated in inch-pound units are to be regarded as standard. The values given in parentheses are mathematical conversions to SI units that are provided for information only and are not considered standard.

<sup>1</sup> This specification is under the jurisdiction of ASTM Committee B05 on Copper and Copper Alloys and is the direct responsibility of Subcommittee B05.04 on Pipe and Tube.

Current edition approved Oct. 1, 2019. Published October 2019. Originally approved in 2007. Last previous edition approved in 2010 as B956/B956M–10<sup>1</sup> which was withdrawn January 2019 and reinstated in October 2019. DOI: 10.1520/B0956–19E01.

1.5 The following safety hazard caveat pertains only to the test methods described in this specification. *This standard does not purport to address all of the safety concerns, if any, associated with its use. It is the responsibility of the user of this standard to establish appropriate safety, health, and environmental practices and determine the applicability of regulatory limitations prior to use.*

1.6 **Warning**—Mercury has been designated by many regulatory agencies as a hazardous substance that can cause serious medical issues. Mercury, or its vapor, has been demonstrated to be hazardous to health and corrosive to materials. Use caution when handling mercury and mercury-containing products. See the applicable product Safety Data Sheet (SDS) for additional information. The potential exists that selling mercury or mercury-containing products, or both, is prohibited by local or national law. Users must determine legality of sales in their location.

1.7 *This international standard was developed in accordance with internationally recognized principles on standardization established in the Decision on Principles for the Development of International Standards, Guides and Recommendations issued by the World Trade Organization Technical Barriers to Trade (TBT) Committee.*

## 2. Referenced Documents

### 2.1 ASTM Standards:<sup>2</sup>

- B153 Test Method for Expansion (Pin Test) of Copper and Copper-Alloy Pipe and Tubing
- B154 Test Method for Mercurous Nitrate Test for Copper Alloys
- B224 Classification of Coppers
- B359/B359M Specification for Copper and Copper-Alloy Seamless Condenser and Heat Exchanger Tubes With Integral Fins
- B543/B543M Specification for Welded Copper and Copper-Alloy Heat Exchanger Tube

<sup>2</sup> For referenced ASTM standards, visit the ASTM website, www.astm.org, or contact ASTM Customer Service at service@astm.org. For *Annual Book of ASTM Standards* volume information, refer to the standard's Document Summary page on the ASTM website.

\*A Summary of Changes section appears at the end of this standard

- B601 Classification for Temper Designations for Copper and Copper Alloys—Wrought and Cast
- B846 Terminology for Copper and Copper Alloys
- B858 Test Method for Ammonia Vapor Test for Determining Susceptibility to Stress Corrosion Cracking in Copper Alloys
- B968/B968M Test Method for Flattening of Copper and Copper-Alloy Pipe and Tube
- E8/E8M Test Methods for Tension Testing of Metallic Materials
- E29 Practice for Using Significant Digits in Test Data to Determine Conformance with Specifications
- E53 Test Method for Determination of Copper in Unalloyed Copper by Gravimetry
- E54 Test Methods for Chemical Analysis of Special Brasses and Bronzes (Withdrawn 2002)<sup>3</sup>
- E62 Test Methods for Chemical Analysis of Copper and Copper Alloys (Photometric Methods) (Withdrawn 2010)<sup>3</sup>
- E112 Test Methods for Determining Average Grain Size
- E118 Test Methods for Chemical Analysis of Copper-Chromium Alloys (Withdrawn 2010)<sup>3</sup>
- E243 Practice for Electromagnetic (Eddy Current) Examination of Copper and Copper-Alloy Tubes
- E255 Practice for Sampling Copper and Copper Alloys for the Determination of Chemical Composition
- E478 Test Methods for Chemical Analysis of Copper Alloys
- 2.2 ASME Code:<sup>4</sup>
- ASME Boiler and Pressure Vessel Code

3.2.1 *enhanced tube*—tube having a series of metallic ribs on the outside or inside surface, or both, either parallel to the longitudinal axis or circumferentially extended from the tube to increase the effective surface for heat transfer (Figs. 1-3).

3.2.2 *unenanced tube*—tube made by processing strip into a tubular shape and forge welding the edges to make a longitudinal seam with no enhancements on the O.D. or I.D.

**4. Types of Welded Tube**

4.1 Reference Specification B543/B543M for the types of forge welded tube products that will be supplied for the enhancing operation (Section 6).

**5. Ordering Information**

5.1 Include the following information when placing orders for product under this specification as applicable:

- 5.1.1 ASTM designation and year of issue;
- 5.1.2 Copper UNS No. designation (for example, Copper UNS No. C12000);
- 5.1.3 Tube type (Section 4);
- 5.1.4 Temper (Section 8);
- 5.1.5 Dimensions, the diameter, wall thickness, whether minimum or nominal wall, and length (Section 14);
- 5.1.6 Configuration of enhanced surfaces shall be agree upon between the manufacturer and the purchaser (Figs. 1-3); and
- 5.1.7 Quantity.

5.2 The following options are available but may not be included unless specified at the time of placing of the order when required:

- 5.2.1 Heat identification or traceability details (6.1.2);
- 5.2.2 Electromagnetic (eddy current) examination;
- 5.2.3 Embrittlement test (12.1);
- 5.2.4 Expansion test (11.1);
- 5.2.5 Flattening test (11.2);
- 5.2.6 Reverse bend test (11.3);
- 5.2.7 Certification (Section 23);
- 5.2.8 Mill Test Reports;

**3. Terminology**

3.1 For the definitions of terms related to copper and copper alloys, refer to Terminology B846.

3.2 *Definitions of Terms Specific to This Standard:*

<sup>3</sup> The last approved version of this historical standard is referenced on www.astm.org.

<sup>4</sup> Available from American Society of Mechanical Engineers (ASME), ASME International Headquarters, Two Park Ave., New York, NY 10016-5990, http://www.asme.org.

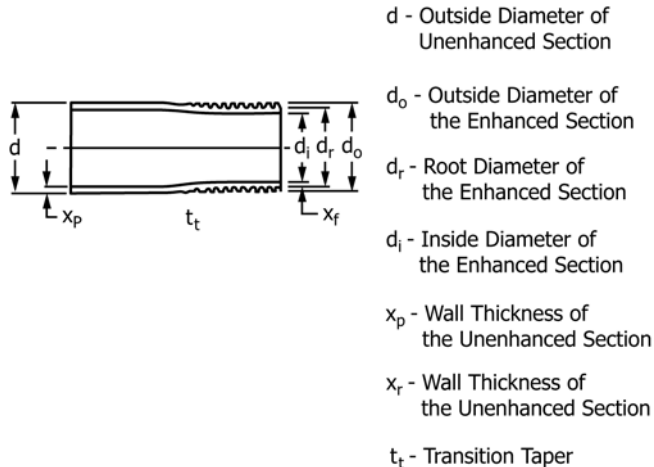

NOTE 1—The outside diameter over the enhanced section will not normally exceed the outside diameter of the unenhanced section.  
**FIG. 1 Outside Diameter Enhanced Tube Nomenclature**

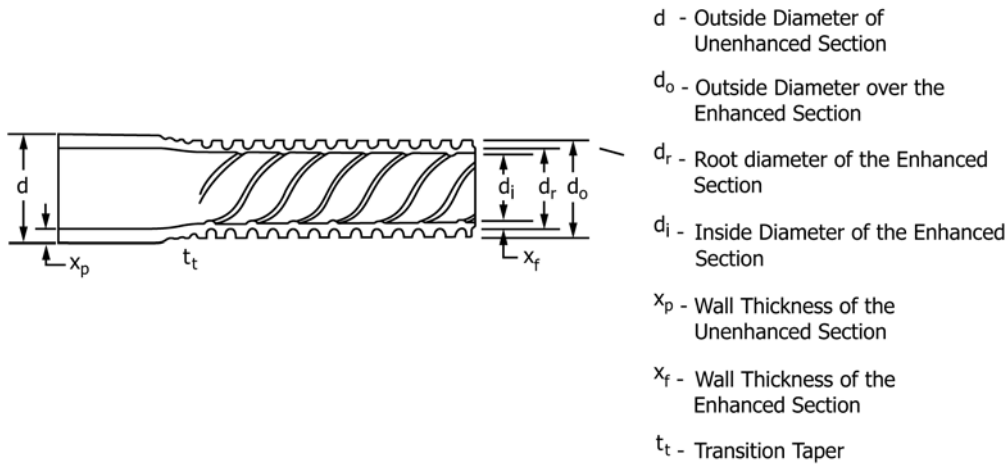

FIG. 2 Outside Diameter and Inside Diameter Enhanced Tube Nomenclature

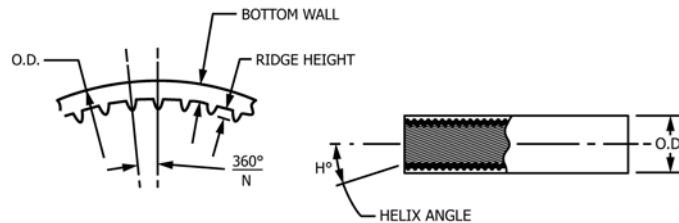

FIG. 3 Inside Diameter Enhanced Tube Nomenclature

5.2.9 If product is purchased for agencies of the U.S. Government (see the Supplementary Requirements section of {this specification or the general requirements section} for additional requirements, if specified); and

5.2.10 If product is ordered for ASME Boiler and Pressure Vessel Code Application (see Certification Section 23).

**6. Materials and Manufacture**

**6.1 Material:**

6.1.1 The material of manufacture shall be welded tube of one of the Copper Alloy UNS Nos. listed in 1.1 of such purity and soundness as to be suitable for processing into the products prescribed herein.

6.1.2 When specified in the contract or purchase order that heat identification or traceability is required, the purchaser shall specify the details desired.

**6.2 Manufacture:**

6.2.1 The product shall be manufacture by cold forming the enhancement of the heat transfer surfaces.

6.3 Product described by this specification shall typically be furnished with unenhanced ends, but may be furnished with enhanced ends or stripped ends from which the O.D. enhancement has been removed by machining.

6.3.1 The enhanced sections of the tube in the as-fabricated temper are in the cold formed condition produced by the enhancing operation.

6.3.2 The unenhanced sections of the tube shall be in the annealed or as-welded temper, and shall be suitable for rolling-in operations.

**7. Chemical Composition**

7.1 The material shall conform to the chemical compositional requirements in Table 1 for Copper UNS No. designation specified in the ordering information.

7.2 The composition limits do not preclude the presence of other elements. By agreement between the manufacturer and purchaser, limits may be established and analysis required for unnamed elements.

7.2.1 *Copper Alloy C19200 and C19400*—Copper may be taken as the difference between the sum of results for all specified elements and 100 %. When all elements specified, including copper, are determined, their sum shall be 99.8 % minimum.

7.2.2 For alloys in which copper is specified as the remainder, copper may be taken as the difference between the sum of the results for all specified elements and 100 % for the particular alloy.

7.2.2.1 When analyzed, copper plus the sum of results for specified elements shall conform with the requirements shown in the following table:

Copper Alloy UNS No.	Copper Plus Named Elements, % min
C70400	99.5
C70600	99.5
C70620	99.5
C71000	99.5
C71500	99.5
C71520	99.5
C72200	99.8

**TABLE 1 Chemical Requirements**

Copper or Copper Alloy UNS No.	Composition, %												
	Copper	Tin	Aluminum	Nickel, incl Cobalt	Lead, max	Iron	Zinc	Manganese	Arsenic	Antimony	Phosphorus	Chromium	Other Named Elements
C12000	99.90 min <sup>A</sup>	...	...	...	...	...	...	...	...	...	0.004–0.012	...	...
C12200	99.9 min <sup>A</sup>	...	...	...	...	...	...	...	...	...	0.015–0.040	...	...
C19200	98.5 min <sup>B</sup>	...	...	...	...	0.8–1.2	0.20 max	...	...	...	0.01–0.04	...	...
C19400	97.0 min <sup>B</sup>	...	...	...	0.03	2.1–2.6	0.05–0.20	...	...	...	0.015–0.15	...	...
C23000	84.0–86.0 <sup>B</sup>	...	...	...	0.05	0.05 max	remainder	...	...	...	...	...	...
C44300	70.0–73.0 <sup>C</sup>	0.9–1.2	...	...	0.07	0.06 max	remainder	...	0.02–0.06	...	...	...	...
C44400	70.0–73.0 <sup>C</sup>	0.9–1.2	...	...	0.07	0.06 max	remainder	...	...	0.02–0.10	...	...	...
C44500	70.0–73.0 <sup>C</sup>	0.9–1.2	...	...	0.07	0.06 max	remainder	...	...	...	0.02–0.10	...	...
C68700	76.0– 79.0 <sup>A,D</sup>	...	1.8–2.5	...	0.07	0.06 max	remainder	...	0.02–0.06	...	...	...	...
C70400	remain- der <sup>A,D</sup>	...	...	4.8–6.2	0.05	1.3–1.7	1.0 max	0.30–0.8	...	...	...	...	...
C70600	remain- der <sup>A,D</sup>	...	...	9.0–11.0	0.05	1.0–1.8	1.0 max	1.0 max	...	...	...	...	...
C70620	86.5 min <sup>A,D</sup>	...	...	9.0–11.0	0.02	1.0–1.8	0.50 max	1.0 max	...	...	0.02 max	...	0.05 C max 0.02 S max
C71000	remain- der <sup>A,D,E</sup>	...	...	19.0–23.0	0.05	1.0 max	1.0 max	1.0 max	...	...	...	...	...
C71500	remain- der <sup>A,D</sup>	...	...	29.0–33.0	0.05	0.40–1.0	1.0 max	1.0 max	...	...	...	...	...
C71520	65.0 min <sup>A,D</sup>	...	...	29.0–33.0	0.02	0.40–1.0	0.50 max	1.0 max	...	...	0.02 max	...	0.05 C max 0.02 S max
C72200	remain- der <sup>A,B,E</sup>	...	...	15.0–18.0	0.05	0.50–1.0	1.0 max	1.0 max	...	...	...	0.30–0.7	0.03 Si max 0.03 Ti max

<sup>A</sup> Copper (including silver).

<sup>B</sup> Cu + Sum of Named Elements, 99.8 % min.

<sup>C</sup> Cu + Sum of Named Elements, 99.6 % min.

<sup>D</sup> Cu + Sum of Named Elements, 99.5 % min.

<sup>E</sup> When the product is for subsequent welding applications, and so specified in the contract or purchase order, zinc shall be 0.50 % max, lead 0.02 % max, phosphorus 0.02 % max, sulfur 0.02 % max, and carbon 0.05 % max.

iTech Standards  
(<https://standards.iteh.ai>)

7.2.3 For alloys in which zinc is specified as the remainder, either copper or zinc may be taken as the difference between the sum of the results of specified elements analyzed and 100 %.

7.2.3.1 When all specified elements are determined, the sum of results plus copper shall be as follows:

Copper Alloy UNS No.	Copper Plus Named Elements, % min
C23000	99.8
C44300, C44400, C44500	99.6
C68700	99.5

## 8. Temper

8.1 Tempers, as defined in Classification **B601** and this specification, are as follows:

8.1.1 The tube, after enhancing, shall be supplied, as specified, in the annealed (061) or as-fabricated temper.

8.1.1.1 The enhanced sections of tubes in the as-fabricated temper are in the cold formed condition produced by the fabricating operation.

8.1.1.2 The unenhanced sections of tubes in the as-fabricated temper are in the temper of the tube prior to enhancing, welded and annealed (WO61), welded and light cold-worked (WC55), and suitable for rolling-in operations.

8.2 Tubes of Copper Alloy UNS Nos. C23000, C44300, C44400, C44500, and C68700 shall be furnished in the annealed temper or the stress relieved condition as specified in the purchase order unless otherwise agreed upon between the purchaser and the manufacturer.

8.3 Tubes of Copper Alloy UNS Nos. C12200, C19200, C19400, C70400, C70600, C71000, C71500, and C72200 are normally supplied in the temper specified in the purchase order without stress relief treatment.

NOTE 2—Some tubes, when subjected to aggressive environments, may be subject to stress-corrosion cracking because of the residual tensile stresses developed in the enhancing process. For such applications, it is suggested that tubes of Copper Alloy UNS Nos. C23000, C44300, C44400, C44500, and C68700 are subjected to a stress-relieving thermal treatment subsequent to the enhancement process. In Specification **B359/B359M**, the stress relief anneal is mandatory for brass alloys.

## 9. Grain Size for Annealed Tempers

9.1 Samples of annealed temper tubes shall be examined at a magnification of 75 diameters. The grain size shall be determined in the wall beneath the internal enhancement. While there is not grain size range, the microstructure shall show complete recrystallization and the weld zone shall have a structure typical of hot-forged welds.

## 10. Mechanical Property Requirements

### 10.1 Tensile Strength and Yield Strength Requirements:

10.1.1 Product furnished under this specification shall conform to the tensile and yield strength requirements prescribed in **Table 2** when tested in accordance with Test Methods **E8/E8M**.

10.1.2 Acceptance or rejection based upon mechanical properties shall depend only on tensile strength and yield strength.

**TABLE 2 Tensile Requirements**

Copper or Copper Alloy UNS No.	Temper Designation		Tensile Strength min ksi <sup>A</sup> (MPa)	Yield Strength <sup>B</sup> min ksi <sup>A</sup> (MPa)
	Standard	Former		
C12000, C12200,	WO61	annealed	30 (205)	9 (62) <sup>C</sup>
	C19200	annealed	38 (260)	12 (85)
C19400	WO61	annealed	45 (310)	15 (105)
	WC55	light cold-worked	45 (310)	22 (152)
C23000	WO61	annealed	40 (275)	12 (85)
	WC55	light cold-worked	42 (290)	20 (138)
C44300, C44400, C44500	WO61	annealed	45 (310)	15 (105)
	WC55	light cold-worked	50 (345)	35 (241)
C44300, C44400, C44500	WO61	annealed	50 (345)	18 (125)
	WC55	light cold-worked	<sup>D</sup>	<sup>D</sup>
C68700	WO61	annealed	38 (260)	12 (85)
C68700	WC55	light cold-worked	40 (275)	30 (207)
C70400	WO61	annealed	40 (275)	15 (105)
C70400	WC55	light cold-worked	45 (310)	35 (241)
C70600	WO61	annealed	40 (275)	15 (105)
C70600	WC55	light cold-worked	45 (310)	35 (241)
C70620	WO61	annealed	40 (275)	15 (105)
C70620	WC55	light cold-worked		
C71000	WO61	annealed	45 (310)	16 (110)
C71000	WC55	light cold-worked	50 (345)	35 (241)
C71500	WO61	annealed	52 (360)	18 (125)
C71500	WC55	light cold-worked	54 (372)	35 (241)
C71520	WO61	annealed	52 (360)	18 (125)
C71520	WC55	light cold-worked		
C72200	WO61	annealed	45 (310)	16 (110)
C72200	WC55	light cold-worked	50 (345)	30 (207)

<sup>A</sup> ksi = 1000 psi.

<sup>B</sup> At 0.5 % extension under load.

<sup>C</sup> Light straightening operation is permitted.

<sup>D</sup> Where no properties are shown, strength requirements shall be as agreed upon between the purchaser and the manufacturer.

## 11. Performance Requirements

### 11.1 Expansion Test Requirements:

11.1.1 When specified in the contract or purchase order, product in the annealed tempers and the light cold-worked temper shall withstand expansion in accordance with Test Method **B153** and to the extent in **Table 3**.

<https://standards.iteh.ai/catalog/standards/sist/b6e4d187-a111-4140-9000-5b474cc2dac/astm-b956-19e1>

**TABLE 3 Expansion Requirements**

Temper	Copper or Copper Alloy UNS No.	Expansion of Tube Outside Diameter, in Percent of Original Outside Diameter	
Annealed	C12000	30	
	C12200	30	
	C19200	20	
	C19400	20	
	C23000	20	
	C44300, C44400, C44500	20	
	C68700	20	
	C70400	30	
	C70600, 70620	30	
	C71000	30	
	C71500, C71520	30	
	C72200	30	
	Light cold-worked	C12200	20
		C19400	20
C70400		20	
C70600		20	
C71000		20	
C71500		20	
C71640		20	
C72200		20	

11.1.2 The expanded tube area shall be free of defects, but blemishes of nature that do not interfere with the intended application are acceptable.

### 11.2 Flattening Test:

11.2.1 When specified in the contract or purchase order, the flattening test in accordance with Test Method **B968/B968M** shall be performed.

11.2.1.1 During inspection, the flattened areas of the test specimen shall be free of defects, but blemishes of a nature that do not interfere with the intended application are acceptable.

### 11.3 Reverse Bend Test:

11.3.1 When specified in the contract or purchase order, the reverse bend test described in the test method section in **19.2.7** shall be performed on unenhanced tubes.

11.3.2 The sample shall be free of defects, but blemishes of nature that do not interfere with the intended application are acceptable.

## 12. Other Requirements

### 12.1 Mercurous Nitrate Test or Ammonia Vapor Test:

12.1.1 When specified in the contract or purchase order, product in drawn tempers shall be tested for residual stress in accordance with the requirements of Test Method **B154** or Test Method **B858**, and show no signs of cracking only for Copper Alloys Nos. C23000, C44300, C44400, C44500, C60800, and C68700. (**Warning**—Mercury is a definite health hazard. With the Mercurous Nitrate Test, equipment for the detection and removal of mercury vapor produced in volatilization, and the use of protective gloves is recommended.)

12.1.2 The test specimens, cut 6 in. (150 mm) in length from the enhanced section shall withstand, without cracking, an immersion in the standard mercurous nitrate solution in Test Method B154 or immersion in the ammonia vapor solution as defined in Test Method B858.

12.1.3 Unless otherwise agreed upon between the manufacturer, or supplier, and the purchaser, the manufacturer shall have the option of using either the mercurous nitrate test or the ammonia vapor test. If agreement cannot be reached, the mercurous nitrate test standard shall be utilized.

12.1.4 If the ammonia vapor test, Test Method B858 is selected, the appropriate risk level pH value for the test solution shall be agreed upon by the manufacturer and purchaser, or alternately, if the purchaser defers to the manufacturer's expertise for the selection of the test pH value, the minimum value selected shall be 9.8.

### 13. Nondestructive Testing

13.1 Each tube shall be subjected to an eddy-current test in 13.2. Fully finished tube (see 4.1) may be tested in the as-fabricated or annealed tempers, unless otherwise agreed upon between the manufacturer or supplier and the purchaser. The purchaser may specify either of the tests in 13.3 or 13.4 as an alternative to the eddy-current test.

13.2 *Eddy Current Test*—Each tube shall be passed through an eddy-current testing unit adjusted to provide information on the suitability of the tube for the intended application. Testing shall follow the procedures of Practice E243, except as modified in 19.2.8.1.

13.2.1 Tubes that do not actuate the signaling device of the eddy-current tester shall be considered as conforming to the requirements of this test. Tubes causing irrelevant signals because of moisture, soil, and like effects may be reconditioned and retested. Such tubes, when retested to the original test parameters, shall be considered to conform if they do not cause output signals beyond the acceptable limits. Tubes causing irrelevant signals because of visible and identifiable handling marks may be retested by the hydrostatic test prescribed in 13.3, or the pneumatic test prescribed in 13.4. Tubes meeting requirements of either test shall be considered to conform if the tube dimensions are within the prescribed limits, unless otherwise agreed to by the manufacturer or supplier and the purchaser.

13.3 *Hydrostatic Test*—(If required on the purchase order), each tube, without showing evidence of leakage, shall withstand an internal hydrostatic pressure sufficient to subject the material in the unenhanced region of the tube to a fiber stress of 7000 psi (48 MPa), as determined by the following equation for thin hollow cylinders under tension:

$$P = \frac{2St}{(D - 0.8t)} \quad (1)$$

where:

- $P$  = hydrostatic pressure, psig (MPa);
- $t$  = thickness of tube wall, in. (mm);
- $D$  = outside diameter of tube, in. (mm); and
- $S$  = allowable fiber stress of the material, psi (MPa).

13.3.1 The tube need not be tested at a hydrostatic pressure over 1000 psi (6.9 MPa) unless so specified.

13.4 *Pneumatic Test*—(If required on the purchase order), each tube, after enhancing, shall withstand a minimum internal air pressure of 250 psig (1.7 MPa) for 5 s and any evidence of leakage shall be cause for rejection. The test method used shall permit easy visual detection of any leakage, such as having the tube under water, or by the pressure differential method.

#### 13.5 ASME Pressure Vessel Code:

13.5.1 When tubes are specified to meet the requirements of the ASME Boiler and Pressure Vessel Code, eddy current testing as described in 13.2 is required on enhanced tube, and a pressure test as described in 13.3 or 13.4 is required.

### 14. Dimensions, Mass, and Permissible Variations

14.1 *Diameters*—The outside diameter of the tubes shall not vary from that specified by more than the amounts shown in Table 4 as measured by “go” and “no-go” ring gauges. Where no values are shown in the table, diameters shall be as agreed upon between the manufacturer and the purchaser.

#### 14.2 Wall Thickness Tolerances:

14.2.1 *Tubes Ordered to Minimum Wall*—No tube at its thinnest point shall be less than the specified wall thickness or greater the specified wall thickness plus twice the tolerances shown in Table 5 and Table 6.

14.2.2 *Tubes Ordered to Nominal Wall*—The maximum plus and minus deviation from the nominal wall at any point shall not exceed the values shown in Table 5 and Table 6.

14.3 *Length*—The length of the tubes shall not be less than that specified when measured at a temperature of 20 °C, but may exceed the specified value by the amounts given in Table 7.

14.4 *Squareness of Cut*—The departure from squareness of the end of any tube shall not exceed the values shown in Table 8.

NOTE 3—For the purpose of determining conformance with the dimensional requirements prescribed in this specification, any measured value outside the specified limiting values for any dimension may be cause for rejection.

### 15. Workmanship, Finish, and Appearance

15.1 Roundness, straightness, uniformity of the wall thickness, and inner and outer surface of the tube shall be such as to make it suitable for the intended application. Unless otherwise specified on the purchase order, the cut ends of the tubes shall be deburred by use of a rotating wire wheel or other suitable tool.

15.2 Welded and annealed, fully finished annealed shall be clean and smooth but may have a superficial, dull iridescent film on both the inside and the outside surfaces. All other tubes shall be clean and smooth but may have a superficial film of

**TABLE 4 Diameter Tolerances**

Specified Diameter, in. (mm)	Tolerance, in. (mm)
0.500 (12.0) and under	±0.002 (0.050)
Over 0.500–0.740 (12.0–18.0), incl	±0.0025 (0.063)
Over 0.740–1.000 (18.0–25.0), incl	±0.003 (0.076)