



Standard Test Methods for Bicycle Frames¹

This standard is issued under the fixed designation F2711; the number immediately following the designation indicates the year of original adoption or, in the case of revision, the year of last revision. A number in parentheses indicates the year of last reapproval. A superscript epsilon (ϵ) indicates an editorial change since the last revision or reapproval.

1. Scope

1.1 These test methods establish procedures for conducting tests to determine the structural performance properties of bicycle frames.

1.2 These test methods describe mechanical tests for determining the following performance properties:

1.2.1 ~~Frame Fatigue—Horizontal Loading~~; Fatigue – Horizontal Loading

1.2.2 ~~Frame Fatigue—Vertical Loading~~, and Fatigue – Vertical Loading

1.2.3 Falling Mass – Horizontal Loading

1.2.4 ~~Frame Impact Strength~~; Falling Frame – Vertical Loading

1.3 The values stated in SI units are to be regarded as standard. No other units of measurement are included in this standard.

1.4 *This standard does not purport to address all of the safety concerns, if any, associated with its use. It is the responsibility of the user of this standard to establish appropriate safety, health, and ~~health~~ environmental practices and determine the applicability of regulatory limitations prior to use.*

1.5 *This international standard was developed in accordance with internationally recognized principles on standardization established in the Decision on Principles for the Development of International Standards, Guides and Recommendations issued by the World Trade Organization Technical Barriers to Trade (TBT) Committee.*

2. Referenced Documents

2.1 *ASTM Standards:*²

E4 Practices for Force Verification of Testing Machines

3. Terminology

3.1 *Definitions of Terms Specific to This Standard:*

3.1.1 *bicycle, n*—two-wheeled, single track, articulated vehicle that is solely human powered.

3.1.1 *bicycle fork, n*—structural connection between the front wheel and the frame.

3.1.1.1 *Discussion*—

The fork transmits steering torque from the handlebars to the front wheel.

3.1.2 *bicycle frame, n*—structural member that supports the seat with rear connection for the rear wheel, front connection via the head tube for the fork and lower connection for the crank/pedal assembly.

3.1.3 *bottom bracket shell, n*—structural member of the frame that houses the assembly that supports the bearings, which support the cranks.

3.1.4 *crank, n*—lever arm that receives human energy as torque to convert into bicycle motion.

3.1.5 *crown race seat, n*—position on the fork where the lower steering axis bearing sits.

3.1.6 *down tube, n*—lower structural connection between the head tube and the bottom bracket shell.

¹ ~~This~~ These test method ~~is~~ methods are under the jurisdiction of ASTM Committee F08 on Sports Equipment, Playing Surfaces, and Facilities and ~~is~~ are the direct responsibility of Subcommittee F08.10 on Bicycles.

Current edition approved Nov. 1, 2012 Oct. 1, 2019, Published December 2012 November 2019. Originally approved in 2008. Last previous edition approved in 2008 2012 as F2711 – 08. DOI: 10.1520/F2711-08- 08 (2012). DOI: 10.1520/F2711-19.

² For referenced ASTM standards, visit the ASTM website, www.astm.org, or contact ASTM Customer Service at service@astm.org. For *Annual Book of ASTM Standards* volume information, refer to the standard's Document Summary page on the ASTM website.

3.1.7 *dropout centerline, n*—hub-mounting axis that passes through both right and left dropouts.

3.1.8 *front dropout, n*—area where the front wheel hub connects to the fork.

3.1.9 *head tube, n*—forward most structural member of the frame, which provides an interface through top, and bottom bearings for the fork.

3.1.9.1 *Discussion*—

The head tube is connected to the seat tube through the top tube and the down tube.

3.1.10 *initial running displacement, n*—average displacement between approximately 500 and 1000 cycles during a durability fatigue test.

3.1.11 *normal attitude, n*—intended position of the bicycle frame when in continuous straight-line motion on a flat surface.

3.1.12 *rake, n*—straight-line distance from the front axle center to the perpendicular of the steering axis.

3.1.13 *rear dropout, n*—area where the rear wheel hub connects to the lower rear and the upper rear frame members.

3.1.14 *sag, n*—amount of compression in a suspension unit, given in a percentage.

3.1.15 *seat post, n*—structural component that connects the seat to the seat tube.

3.1.16 *seat tube, n*—structural member of the frame into which the seat post inserts.

3.1.17 *steerer tube, n*—section of the bicycle fork that is housed within the head tube and bearing assemblies.

3.1.18 *top tube, n*—upper structural connection between the head tube and the seat tube.

3.2 *Acronyms:*

3.2.1 *OEM, n*—original equipment from manufacturer

3.3 *Symbols:*

L = fork length, a straight-line measure from the crown race seat to the center of the front axle.

δ = deflection of test fork.

4. Summary of Test Methods

4.1 *Horizontal Loading Durability Fatigue Test*—This test method restrains the frame at the rear dropouts (see Fig. 1). A cyclic load is applied along the x-axis at the front dropouts. The number of cycles is measured. The magnitude of the load, and the minimum number of cycles, are determined by the specification standard.

4.2 *Vertical Loading Durability Fatigue Test*—This test method restrains the frame at the rear dropouts, and allows free rolling at the fork (see Fig. 2). A cyclic load is applied along the Z-axis behind the seat post. The number of cycles is measured. The magnitude of the load, and the minimum number of cycles, are determined by the specification standard.

4.3 *Impact Strength Falling Mass Test*—This test method restrains the frame vertically at the rear dropouts (see Fig. 3). A mass is dropped onto a roller assembly attached to the fork. Permanent set is measured. The height of the drop is determined by the specification standard.

4.4 *Falling Frame Test*—This test method pins the frame at the rear dropouts (see Fig. 4), weight is loaded on the frame, the frame rotates to drop onto a roller in the front dropouts.

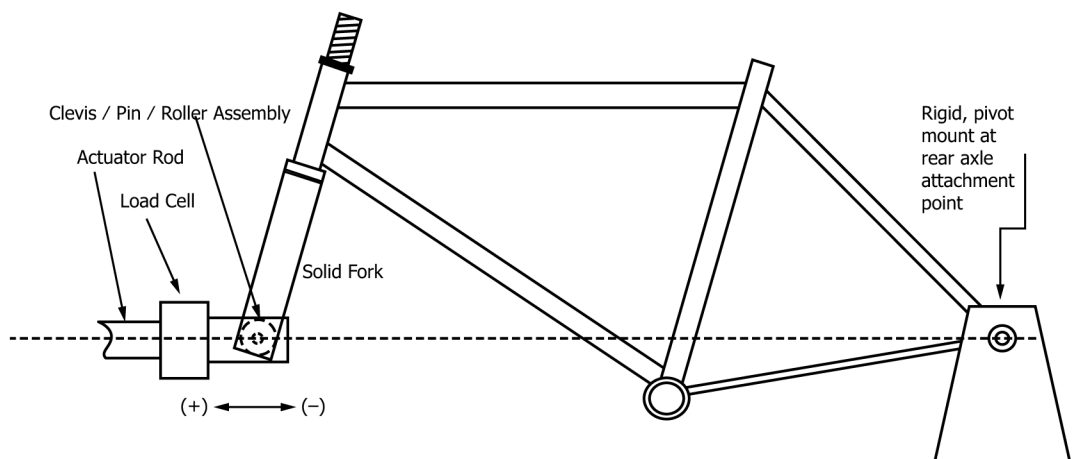

FIG. 1 Horizontal Fatigue Test

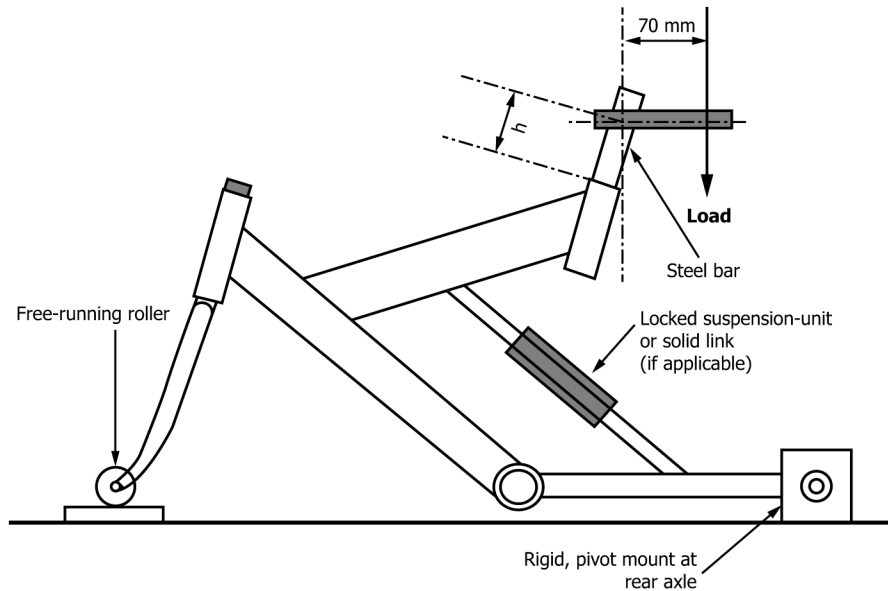

FIG. 2 Vertical Fatigue Test

5. Significance and Use

5.1 These tests are used to verify the durability and strength of a bicycle frame.

6. Apparatus

6.1 Requirements for Test Forks:

6.1.1 The test forks shall be designed to mount in a manner similar to the OEM fork, or in a manner using typical bicycle assembly procedures.

6.1.2 The test forks, when mounted, shall be the same length, L , as the longest fork designed for use with the frame and have a rake of 45 ± 6 mm. When the test fork is used in place of an OEM Suspension fork, the length is determined by the dropout position when the suspension fork is compressed no more than 20 % of its maximum amount of travel.

6.1.3 The deflection of a test fork is measured at the front axle center, resulting from the application of a vertical 1200 N load at that point. The fork is fixed in position only at the steerer tube by a v-block with minimum length of 76 mm. The steerer tube is fixed horizontally with the crown race seat adjacent to the v-block.

6.1.4 The deflection ratio for the Test fork for the Horizontal Loading Fatigue test and the Vertical Loading Fatigue test shall not exceed the value of 1.0 when computed as follows:

$$\text{Deflection ratio} = \frac{K \times 10\,000 \times \delta}{L^3}$$

Where:

K (a constant) = 1417 for L and δ in millimetres.

(For example, a fork length of 460 mm, the maximum acceptable fork deflection (δ) would be 6.9 mm. Similarly for a fork length of 330 mm, the maximum deflection is 2.5 mm.)

6.1.5 The deflection ratio for the Test fork for the Impact test shall not exceed the value of 1.0 when computed as follows:

$$\text{Deflection ratio} = \frac{K \times 10\,000 \times \delta}{L^3}$$

Where:

K = 709 for L and δ in millimetres.

6.2 Horizontal Loading Durability Fatigue Test:

6.2.1 A fixture is required to restrain the frame at the rear dropouts, while allowing free rotation about the axle (see Fig. 1). In the case of a suspension frame, the suspension must be locked in a position equivalent to the manufacturer's recommendation for sag, sag for an 80 kg rider, or 25 % sag if none was recommended. If the suspension does not permit locking, then replace the suspension unit with a solid link providing the equivalent sag geometry.

6.2.2 A test fork meeting the requirements for this test (see 6.1) shall be used.

6.2.3 The fork shall be attached to the bicycle frame head tube using typical bicycle assembly practices.

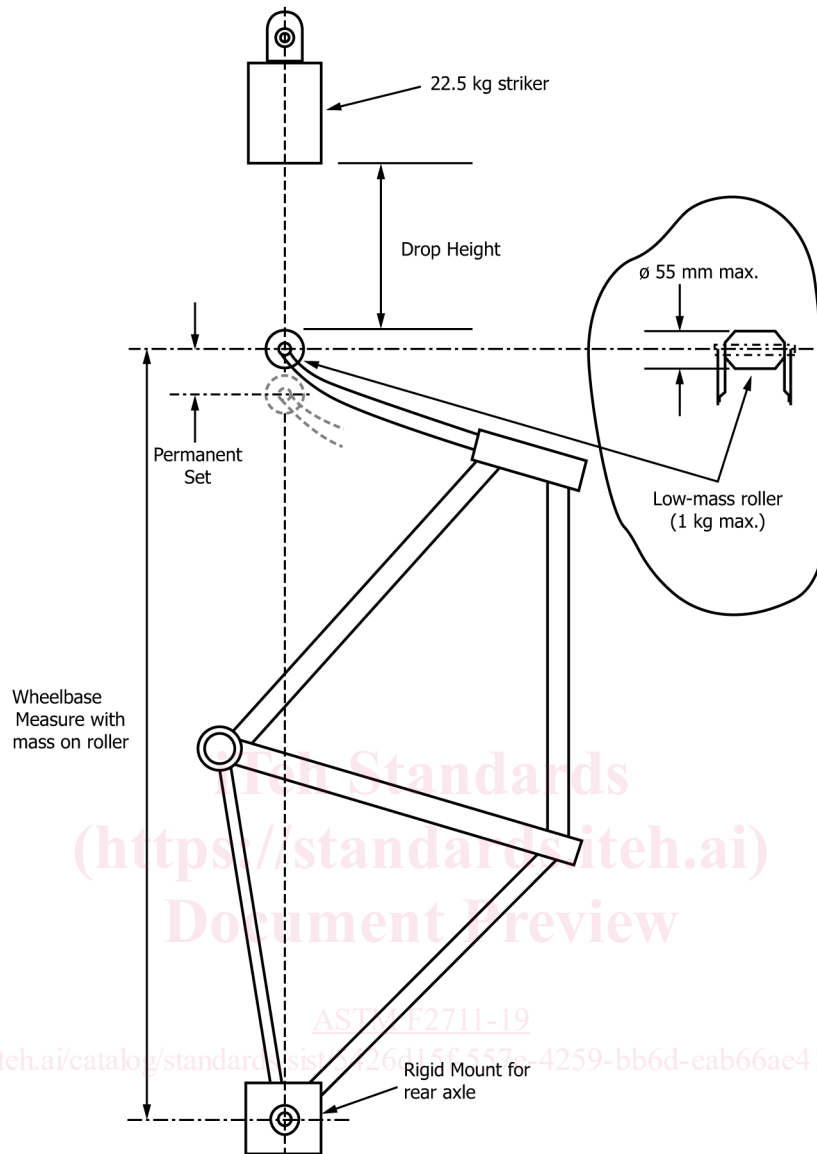

FIG. 3 Frame Impact Falling Mass Test

6.2.4 The fork assembly shall be restrained at the dropouts in such a way that allows translation along the X-axis, and rotation about the Y-axis.

6.2.5 The front and rear dropouts are to be equal in height when the frame and fork assembly is fixtured.

6.2.6 An actuator mounted load cell or equivalent apparatus that is capable of providing a reversible load of constant amplitude shall be attached to the front dropouts or front axle, without constricting the rotational freedom of the fork assembly.

6.2.7 This apparatus shall allow cyclic load application to the front dropouts in a longitudinal direction along the bicycle centerline.

6.3 Vertical Loading Durability Fatigue Test:

6.3.1 A fixture is required to restrain the frame at the rear dropouts, while allowing free rotation about the rear axle (Fig. 2). In the case of a suspension frame, the suspension must be locked in a position equivalent to the manufacturer's recommendation for sag, sag for an 80 kg rider, or 25 % sag if none was recommended. If the suspension does not permit locking, then replace the suspension unit with a solid link providing the equivalent sag geometry.

6.3.2 A test fork meeting the requirements for this test (see 6.1) shall be used.

6.3.3 The fork shall be attached to the bicycle frame head tube using typical bicycle assembly practices.

6.3.4 The fork assembly shall be restrained at the dropouts in such a way that allows translation along the X-axis (see Fig. 45); and free rotation of the fork assembly about the front axle; while movement in the Y-axis and Z-axis is constrained.

6.3.5 The front and rear dropouts are to be equal height when the frame and fork assembly is fixtured.