



Designation: F319 – 19

Standard Practice for Polarized Light Detection of Flaws in Aerospace Transparency Heating Elements¹

This standard is issued under the fixed designation F319; the number immediately following the designation indicates the year of original adoption or, in the case of revision, the year of last revision. A number in parentheses indicates the year of last reapproval. A superscript epsilon (ϵ) indicates an editorial change since the last revision or reapproval.

INTRODUCTION

Electrically conductive coatings used in aerospace transparencies for heating purposes often contain flaws resulting from imperfections of materials, imperfections of manufacturing techniques, handling damage, or contamination. Flaws develop before, during, or after coating and processing and usually appear as hairline cracks, scratches, or pin holes. When these flaws are of sufficient size, hot spots occur as a result of disruption and concentration of the flow of electrical current adjacent to the flaws. These hot spots may result in reduced service life of the transparency. Hot spot flaws in the transparency may also produce undesirable temporary distortion of vision during powered operation of the heater and permanent vision distortion after repeated cycling of the heater.

Polarized light is widely used to detect electrically conductive coating flaws during aerospace transparency processing.

1. Scope

1.1 This practice covers a standard procedure for detecting flaws in the conductive coating (heater element) by the observation of polarized light patterns.

1.2 This practice applies to coatings on surfaces of monolithic transparencies as well as to coatings imbedded in laminated structures.

1.3 The values stated in SI units are to be regarded as standard. No other units of measurement are included in this standard.

1.4 *This standard does not purport to address all of the safety concerns, if any, associated with its use. It is the responsibility of the user of this standard to establish appropriate safety, health, and environmental practices and determine the applicability of regulatory limitations prior to use.* For specific precautionary statements, see Section 6.

1.5 *This international standard was developed in accordance with internationally recognized principles on standardization established in the Decision on Principles for the Development of International Standards, Guides and Recommendations issued by the World Trade Organization Technical Barriers to Trade (TBT) Committee.*

2. Terminology

2.1 Definitions:

2.1.1 *transparent conductive coating, n*—a transparent thin film of electrically conductive material such as gold, silver, tin oxide, or indium tin oxide applied to plastic or glass which, when bounded by connecting bus-bars energized by electricity, becomes a resistance type heating element.

2.1.2 *electrically conductive coating flaw, n*—an electrical discontinuity in the coating, caused generally by coating cracks, pin holes, fine threads, scratches, and so forth.

3. Summary of Practice

3.1 Flaws in electrically powered conductive coatings produce local concentrations of current, which result in temperature gradients and stresses. Since glass and plastic transparencies are birefringent when stressed, flaws are detectable by optical methods, and in this case by the use of polarized light.

3.2 This practice consists of directing polarized light through a heated transparent test specimen and reading the transmitted light with a polarizing screen or filter. Diffracted light from the region of the flaw will become visible, in the form of a brighter or more intense local image, usually shaped like a butterfly.

4. Significance and Use

4.1 This practice is useful as a screening basis for acceptance or rejection of transparencies during manufacturing so that units with identifiable flaws will not be carried to final inspection for rejection at that time.

¹ This practice is under the jurisdiction of ASTM Committee F07 on Aerospace and Aircraft and is the direct responsibility of Subcommittee F07.08 on Transparent Enclosures and Materials.

Current edition approved Nov. 1, 2019. Published November 2019. Originally approved in 1977. Last previous edition approved in 2014 as F319 – 09(2014). DOI: 10.1520/F0319-19.

4.2 This practice may also be employed as a go-no go technique for acceptance or rejection of the finished product.

4.3 This practice is simple, inexpensive, and effective. Flaws identified by this practice, as with other optical methods, are limited to those that produce temperature gradients when electrically powered. Any other type of flaw, such as minor scratches parallel to the direction of electrical flow, are not detectable.

5. Apparatus

5.1 The elements of the apparatus are detailed below in their physical relationship as shown in Fig. 1. The minimum size and spacing of the elements of the apparatus are determined by the size and curvature of the part. The size of light source, light diffuser, and polarizing screen shall be large enough so that every portion of the electrically coated area of the test specimen is in the light path and is uniformly back-lit. If the

test specimen is curved severely, its position may have to be adjusted during inspection so that the light path is within 20° of normal to the location being viewed. Since specimen size and curvature vary considerably, a dimensionally fixed standard is not given.

5.2 The apparatus, in the order of assembly, consists of the following:

5.2.1 *Uniform Light Source*, such as a bank of fluorescent lamps.

5.2.2 *Translucent Light Diffusion Plate*, such as milk-white glass located so as to provide a uniform light distribution.

5.2.3 *Polarizing Screen*, which converts the diffused light to polarized light.

5.2.4 *Transparent Dust Shield* (optional).

5.2.5 *Support* for the specimen.

5.2.6 *Polarizing Viewer*, hand-held or mounted so it can be rotated to give maximum contrast as an analyzer.

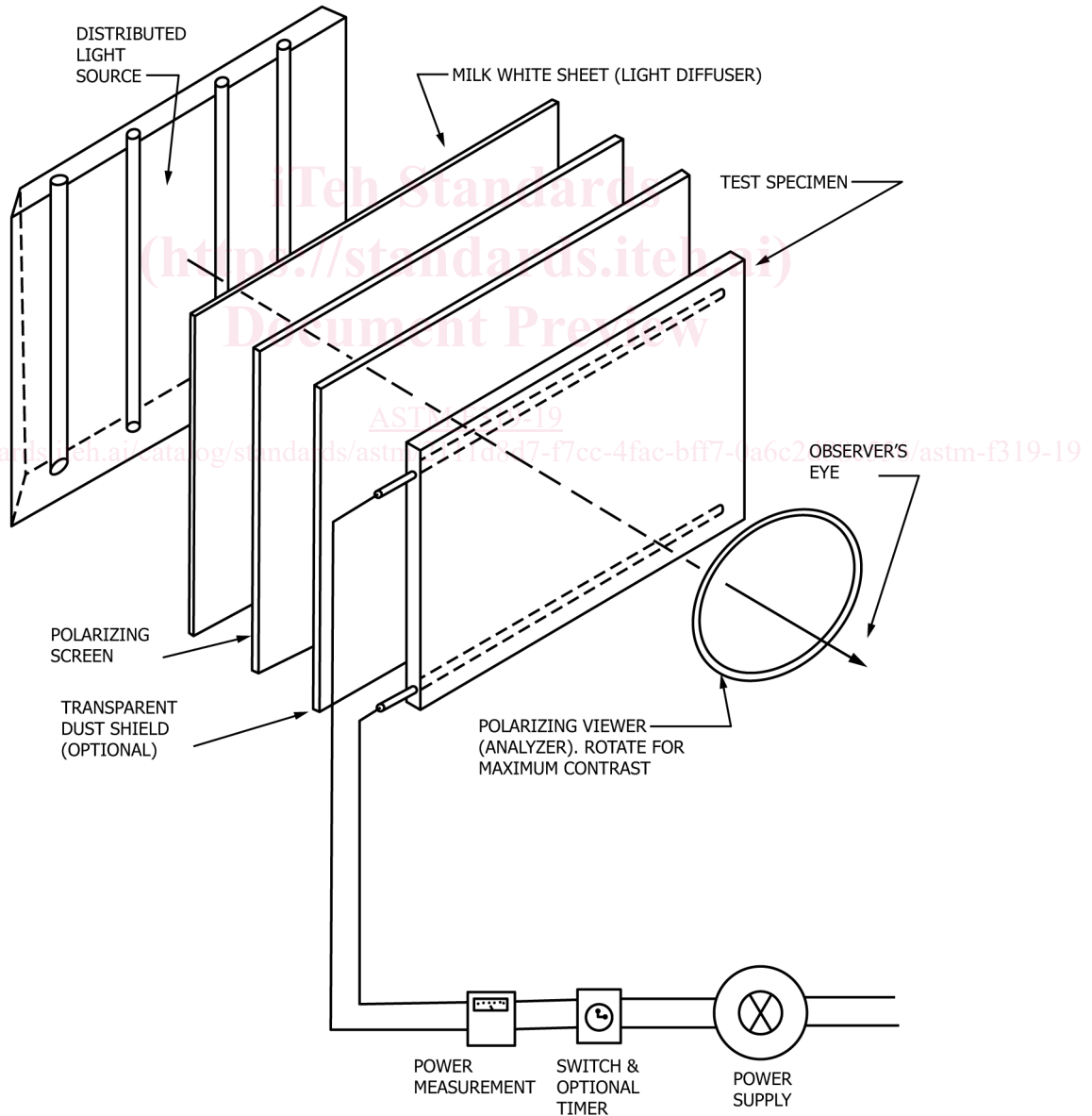

FIG. 1 Typical Arrangement for Polarized Light Method