



Designation: **F1164 – 97 (Reapproved 2014) F1164 – 19**

## Standard Test Method for Evaluation of Transparent Plastics Exposed to Accelerated Weathering Combined with Biaxial Stress<sup>1</sup>

This standard is issued under the fixed designation F1164; the number immediately following the designation indicates the year of original adoption or, in the case of revision, the year of last revision. A number in parentheses indicates the year of last reapproval. A superscript epsilon ( $\epsilon$ ) indicates an editorial change since the last revision or reapproval.

### 1. Scope

1.1 This test method covers the resistance of transparent plastics exposed to environmental conditioning (accelerated weathering) under a biaxial stress state induced by a pressure cell/test fixture.

1.2 *Units*—The values stated in ~~acceptable metric~~ SI units are to be regarded as ~~the standard~~. The values given in parentheses after SI units are provided for information only and are not considered standard.

1.3 *This standard does not purport to address all of the safety concerns, if any, associated with its use. It is the responsibility of the user of this standard to establish appropriate safety, health, and ~~health~~ environmental practices and determine the applicability of regulatory limitations prior to use.*

1.4 *This international standard was developed in accordance with internationally recognized principles on standardization established in the Decision on Principles for the Development of International Standards, Guides and Recommendations issued by the World Trade Organization Technical Barriers to Trade (TBT) Committee.*

### 2. Referenced Documents

2.1 *ASTM Standards:*<sup>2</sup>

D1003 Test Method for Haze and Luminous Transmittance of Transparent Plastics

D3359 Test Methods for Rating Adhesion by Tape Test

G26 Practice for Operating Light-Exposure Apparatus (Xenon-Arc Type) With and Without Water for Exposure of Nonmetallic Materials (Discontinued 2001) (Withdrawn 2000)<sup>3</sup>

G53 Practice for Operating Light-and Water-Exposure Apparatus (Fluorescent UV-Condensation Type) for Exposure of Nonmetallic Materials (Withdrawn 2000)<sup>3</sup>

G90 Practice for Performing Accelerated Outdoor Weathering of Materials Using Concentrated Natural Sunlight

### 3. Summary of Test Method

3.1 This test method consists of measuring and recording the haze and light transmittance of an unexposed circular plate test specimen; specimen, mounting the specimen in the test fixture; fixture, pressurizing the fixture to induce the desired biaxial stress in the specimen; specimen, and exposing the stressed specimen to specific accelerated weathering conditions. After conditioning, the specimen is removed and haze/transmittance are measured to determine any changes in value. Coating adhesion is measured when applicable.

3.2 The resistance of the plastic to stress-during-weathering is determined by the onset of crazing, the change in haze and luminous transmittance, and adhesion of coating.

### 4. Significance and Use

4.1 The degradation of optical properties of transparent plastics is the single greatest cause for in-service removal and replacement. Some optical qualities are inherent in the geometry, manufacturing process, and materials, and remain relatively unchanged after manufacture, while others are subject to gradual change during exposure to the service environment. Factors

<sup>1</sup> This test method is under the jurisdiction of ASTM Committee F07 on Aerospace and Aircraft and is the direct responsibility of Subcommittee F07.08 on Transparent Enclosures and Materials.

Current edition approved Dec. 1, 2014 Nov. 1, 2019. Published December 2014 November 2019. Originally approved in 1988. Last previous edition approved in 2009 2014 as F1164 – 97 F1164(2009) – 97(2014).<sup>2</sup> DOI: 10.1520/F1164-97R14.10.1520/F1164-19.

<sup>2</sup> For referenced ASTM standards, visit the ASTM website, www.astm.org, or contact ASTM Customer Service at service@astm.org. For *Annual Book of ASTM Standards* volume information, refer to the standard's Document Summary page on the ASTM website.

<sup>3</sup> The last approved version of this historical standard is referenced on www.astm.org.

having an influence on the crazing of transparent plastics include stress, ultraviolet (UV), moisture, and temperature. Sufficient data has been generated to make it evident that real-world conditioning must be experienced by developmental test specimens, as opposed to testing new unexposed material to determine durability, prior to in-service usage. However, the laboratory simulation of natural weathering, and especially accelerated simulation, is imprecise and correlation of results obtained for different plastics or from using different exposure apparatus ~~should~~must not be attempted until a valid database has been generated for such cross-correlation.

## 5. Apparatus

5.1 *Manifold Test Fixture*—An exploded view of the pressure-cell/test-fixture used to induce a biaxial stress state in a clamped specimen is illustrated in Fig. 1. The mounting plate and clamping ring for a 76.2-mm (30-in.) wide three-cell test fixture are detailed in Fig. 2. A 254-mm (10-in.) wide single-cell fixture or a 508-mm (20-in.) wide double-cell fixture is also acceptable.

### 5.2 Accelerated Weathering Apparatus:

5.2.1 Operating procedures for using water- or light-exposure apparatus, or both, employing a Xenon-arc light source to simulate the deterioration caused by accelerated weathering exposure, shall comply with Practice G26.

5.2.2 Operating procedures for using fluorescent UV and condensation apparatus to simulate the deterioration caused by accelerated weathering exposure shall comply with Practice G53.

5.2.3 Operating procedures for using Fresnel-reflecting concentrators employing the sun as a source, with or without water spray cycles, to simulate the deterioration caused by accelerated weathering exposure, shall comply with Practice G90.

5.3 *Hazemeter*—The Hazemeter shall conform to the requirements of Test Method D1003.

## 6. Test Specimens

6.1 Use at least three specimens for each material being tested and for each specified exposure. The specimens shall be as follows: clean, transparent circular plates, 0.216 m (8.500 in.) in diameter, having both sides substantially plane and parallel; specimen nominal thickness being 0.00508 m (0.200 in.).

## 7. Conditioning

7.1 Conduct tests in the standard laboratory atmosphere.

## 8. Procedure

8.1 Code mark each specimen. Measure and record haze and transmittance at the plate center prior to exposure.

8.2 Circumferentially clamp specimens in the manifold test fixture using 2.825 J (25 in.-lb) bolt torque, and pressurize to induce an outer surface (tensile) strain of  $13.8 \times 10^6 (1-\nu)/E$  metre/metre (2000 (1- $\nu$ )/ $E$  inch/inch) in the center of the specimen (note that this strain corresponds to a tensile stress of  $13.8 \times 10^6$  Pa or 2000 psi), where  $\nu$  = Poisson's ratio at room temperature and  $E$  = modulus of elasticity (Pa or psi) at room temperature for the test material. For coated material, the outer tensile test/exposure side of each specimen shall be the coated surface.

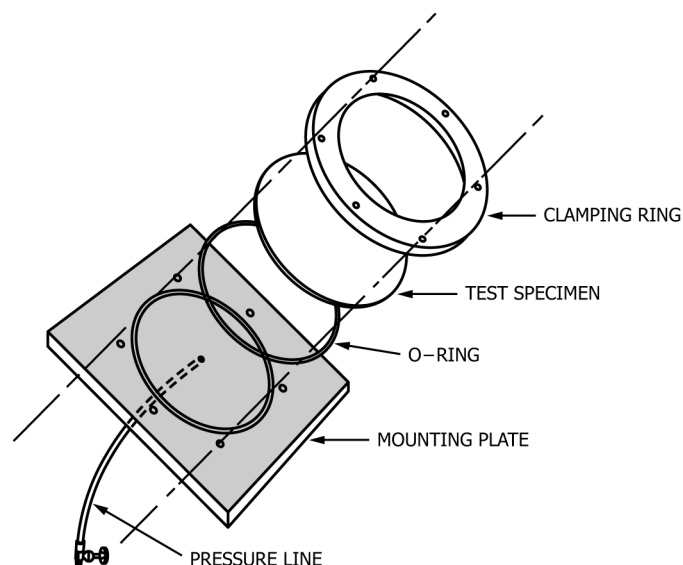

FIG. 1 Stress Weathering Test Apparatus