

INTERNATIONAL STANDARD

ISO
4532

First edition
1991-12-01

Vitreous and porcelain enamels — Determination of the resistance of enamelled articles to impact — Pistol test

iTeh STANDARD PREVIEW

*Émaux vitrifiés — Détermination de la résistance au choc des pièces
émaillées — Essai au pistolet*

ISO 4532:1991

<https://standards.itih.ai/catalog/standards/sist/48321ee5-b08f-488f-b041-10202c4682f8/iso-4532-1991>



Reference number
ISO 4532:1991(E)

Foreword

ISO (the International Organization for Standardization) is a worldwide federation of national standards bodies (ISO member bodies). The work of preparing International Standards is normally carried out through ISO technical committees. Each member body interested in a subject for which a technical committee has been established has the right to be represented on that committee. International organizations, governmental and non-governmental, in liaison with ISO, also take part in the work. ISO collaborates closely with the International Electrotechnical Commission (IEC) on all matters of electrotechnical standardization.

Draft International Standards adopted by the technical committees are circulated to the member bodies for voting. Publication as an International Standard requires approval by at least 75 % of the member bodies casting a vote.

International Standard ISO 4532 was prepared by Technical Committee ISO/TC 107, *Metallic and other inorganic coatings*, Sub-Committee SC 6, *Vitreous and porcelain enamels*.

<https://standards.iteh.ai/catalog/standards/sist/48321ee5-b08f-488f-b041-1042c4982181/iso-4532-1991>

It is based on a test method developed by a committee of the VDEfa. The VDEfa Technical Report No. 4 [1] describes the development of the pistol test and gives comprehensive information on numerous pistol tests carried out on different shapes of test specimens.

Annexes A and B of this International Standard are for information only.

© ISO 1991

All rights reserved. No part of this publication may be reproduced or utilized in any form or by any means, electronic or mechanical, including photocopying and microfilm, without permission in writing from the publisher.

International Organization for Standardization
Case Postale 56 • CH-1211 Genève 20 • Switzerland

Printed in Switzerland

Vitreous and porcelain enamels — Determination of the resistance of enamelled articles to impact — Pistol test

1 Scope

This International Standard specifies a test method for determining the resistance of enamelled articles to impact.

The method is used as a factory production control test.

NOTE 1 The pistol test is not intended to be used for testing the adhesion of the enamel.

2 Normative reference

The following standard contains provisions which, through reference in this text, constitute provisions of this International Standard. At the time of publication, the edition indicated was valid. All standards are subject to revision, and parties to agreements based on this International Standard are encouraged to investigate the possibility of applying the most recent edition of the standard indicated below. Members of IEC and ISO maintain registers of currently valid International Standards.

ISO 2746:1973, *Vitreous and porcelain enamels — Enamelled articles for service under highly corrosive conditions — High voltage test.*

3 Principle

Shooting of a ball-tipped striking bolt of an apparatus operated by adjustable spring tension, against the surface of the test specimen. Evaluation of the point of impact.

The load applied to the striking bolt, which with one blow produces visible damage to the enamel, is inversely proportional to the sensitivity of the enamelled article to impact.

4 Apparatus

The test apparatus (see figure 1) consists of a striking bolt with a 5 mm steel ball tip which is shot once against the surface under test by means of a pressure spring (100 mm long, unloaded). The spring load can be continuously adjusted from 0 to 90 N by the power-adjusting sleeve.

NOTE 2 The newton-metre scale provided on the outside of the apparatus shall only be used as a guide because a non-linear scale can lead to significant errors.

The pressure spring is loaded by means of a clamp. The spring constant is $20 \text{ N/cm} \pm 0,5 \text{ N/cm}$. When the spring is loaded, it is kept stationary by a holder on the striking bolt and released by the trigger for striking. For testing, a tripod can be fixed at the front of the apparatus in order to keep the apparatus vertical against the test surface. The front of the tool is convex-shaped for testing concave articles. For testing articles with small radii, it is supplied with a cross-groove. In the range of application of the apparatus, the error in reading shall not be greater than 3 %.

See annex A for the calibration and determination of the zero point of the apparatus.

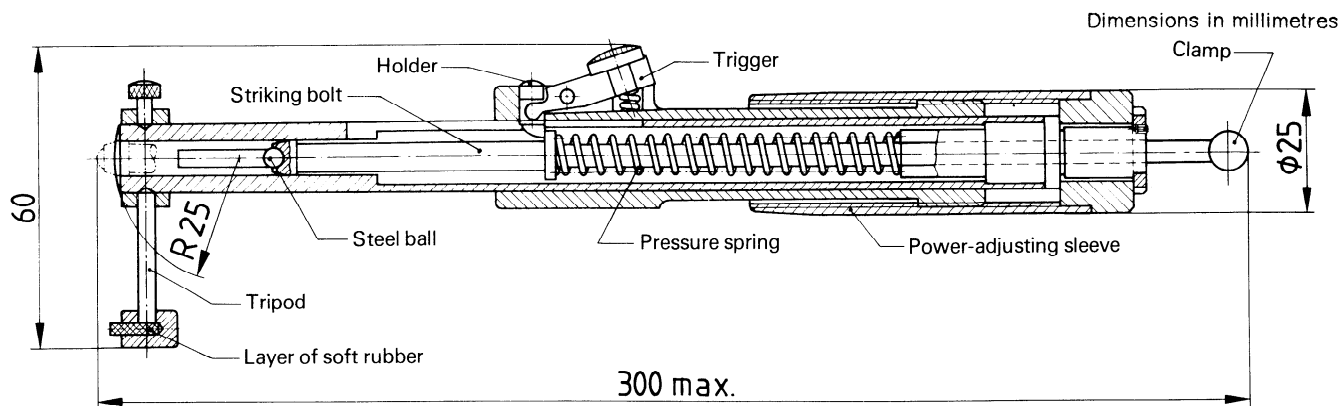

Figure 1 — Test apparatus (The pressure spring is shown loaded)

5 Test specimens

The enamelled articles are the test specimens. The sampling of the test specimens and their number shall be agreed upon between the supplier and the customer. If no agreement had been made, test at least two test specimens.

6 Procedure

The test specimens shall be tested in conditions identical to those used in practice. For testing, the apparatus may be fixed in a strong support and the test specimens fixed with the surfaces to be tested against the front of the apparatus.

Carry out the pistol test at various places with increasing loads.

In a preliminary test, starting with a load of 10 N and increasing by 10 N each time, establish the integer of 10 N at which the enamel is not visibly damaged. From this value onwards, increase the spring load by 2 N each time until the first visible damage is noticed (see clause 7).

The distance between two points of impact, or the distance between a point of impact and a sign of damage on the enamel, shall be at least 20 mm.

The parts of the enamelled articles which shall be submitted to the pistol tests and their conditions of support shall be agreed upon for each case.

Carry out at least five pistol tests.

7 Expression of results

After each pistol test, observe the point of impact from a distance of 250 mm by normal sight and note the type of damage. The final valuation shall be made after 24 h.

The first visible sign of damage of enamel at the point of impact shall be used as a criterion of the impact sensitivity of the enamelled article, for example cracking, powdering off, spalling and chipping. The mark of the striking bolt shall not be considered as sign of damage.

After the pistol test, it is permitted to rub the test specimen with an alcoholic dye solution, an ink or a similar colouring solution, to make the damage more easily visible.

In addition, it can be advantageous to use the high-voltage test (according to ISO 2746) for certain articles, especially those used under highly corrosive conditions.

NOTE 3 Test results can only be compared if

- the test specimens are similar, especially considering the thickness of the basis metal and of the enamel coat;
- the same kind of support was used;
- the pistol tests were applied to similar points on the test specimens.

8 Test report

The test report shall include the following information:

- a reference to this International Standard;
- a description of the articles tested (especially their dimensions and mass, and if possible a sketch; or also the thickness of the basis metal and of the enamel coat);
- the number of specimens tested;
- the type of support used;

- e) the position of the points of impact on the article (for example in the case of pots: rim, bottom, inside or outside);
- f) the number of pistol tests per test specimen;
- g) the spring load used, in newtons, rounded to the nearest 2 N, necessary to damage the enamel;
- h) the appearance of the damaged places, if necessary with photographs;
- i) whether the high-voltage test was used and, if so, the voltage applied.

iTeh STANDARD PREVIEW
(standards.iteh.ai)

[ISO 4532:1991](#)

<https://standards.iteh.ai/catalog/standards/sist/48321ee5-b08f-488f-b041-10202c4682f8/iso-4532-1991>

Annex A
(informative)

Calibration and determination of the zero point of the apparatus

A.1 Calibration

Clamp the striking bolt with its barrel in a vertical position in a support so that the bolt can be loaded and unloaded.

The loading of the striking bolt is effected by dismantling the clamp, thus freeing a hole into which a rod with a length of about 15 cm can be inserted, corresponding to pre-defined striking bolt load.

If the apparatus is supplied with a bolt on the back of the apparatus, dismantling is not necessary as the calibration weights can be fixed there.

Submit the striking bolt to a load of 10 N. Determine, by reading the scale, the position in which the load is neutralized by checking that the striking bolt is just unloaded. Repeat this procedure with increasing loads.

Plot a graph of the readings adjusted as a function of the weight of the rod against the loads. Read the zero-point deviation from the graph (see examples in A.2).

The spring constant is correct when the graph makes an angle of 45° with the axes. If this is not the case, the apparatus is not suitably calibrated and a correction shall be made using the graph.

A.2 Examples for the determination of the zero point of two different apparatuses

The values given in table A.1 were obtained for two different apparatuses, when tested according to A.1.

Table A.1 — Values obtained for two different apparatuses when tested according to A.1

Values in newtons

Load applied	Apparatus reading	
	Apparatus No. 1	Apparatus No. 2
10,0	12,5	17,5
15,0	17,5	23,0
20,0	23,0	27,5
50,0	54,0	57,5

According to figure A.1, the zero deviation of apparatus No. 1 is 3 N, that of apparatus No. 2 is 7 N.

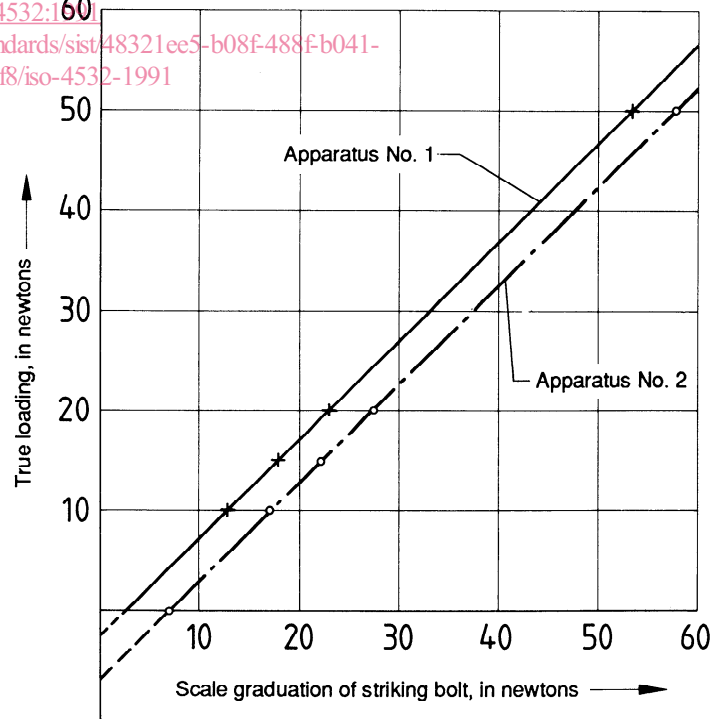

Figure A.1 — Graph for the determination of the zero point of two different apparatuses

Annex B
(informative)

Bibliography

- [1] Fachausschuß-Bericht Nr. 4 des Vereins Deutscher Emailfachleute e.V. *Prüfung von Email: Schlagversuch*. [Technical Report No. 4 of the Society of German Enamel Specialists: *Testing of enamel — Pistol test*]. Publisher Brunke Garrels, Hamburg, 1958. [Available from: Verlag des Vereins Deutscher Emailfachleute e.V., Zehlendorfer Straße 24, D - 5800 Hagen 1.]

iTeh STANDARD PREVIEW
(standards.iteh.ai)

[ISO 4532:1991](#)

<https://standards.iteh.ai/catalog/standards/sist/48321ee5-b08f-488f-b041-10202c4682f8/iso-4532-1991>

iTeh STANDARD PREVIEW
(standards.iteh.ai)

ISO 4532:1991

<https://standards.iteh.ai/catalog/standards/sist/48321ee5-b08f-488f-b041-10202c4682f8/iso-4532-1991>

UDC 666.293:620.178.7

Descriptors: coatings, non metallic coatings, vitreous enamels, porcelain enamels, tests, impact tests.

Price based on 5 pages
