



Designation: ~~D7895/D7895M – 14 (Reapproved 2018)~~ D7895/D7895M – 19

# Standard Test Method for Thermal Endurance of Coating Powders Used for Powder Coating Insulation Systems<sup>1</sup>

This standard is issued under the fixed designation D7895/D7895M; the number immediately following the designation indicates the year of original adoption or, in the case of revision, the year of last revision. A number in parentheses indicates the year of last reapproval. A superscript epsilon ( $\epsilon$ ) indicates an editorial change since the last revision or reapproval.

## 1. Scope

1.1 This test method provides a procedure for evaluating thermal endurance of coating powders by determining the length of aging time at selected elevated temperatures required to achieve dielectric breakdown at room temperature at a pre-determined proof voltage. Thermal endurance is expressed in terms of a temperature index.

1.2 This test method is applicable to insulating powders used over a substrate material of steel.

1.3 *Units*—The values stated in either SI units or inch-pound units are to be regarded separately as standard. The values stated in each system are not necessarily exact equivalents; therefore, each system shall be used independently of the other. Combining values from the two systems is likely to result in non-conformance with the standard.

1.4 *This standard does not purport to address all of the safety concerns, if any, associated with its use. It is the responsibility of the user of this standard to establish appropriate safety, health, and environmental practices and determine the applicability of regulatory limitations prior to use.* Specific precautionary statements are given in Section 7.

1.5 *This international standard was developed in accordance with internationally recognized principles on standardization established in the Decision on Principles for the Development of International Standards, Guides and Recommendations issued by the World Trade Organization Technical Barriers to Trade (TBT) Committee.*

## 2. Referenced Documents

2.1 *ASTM Standards:*<sup>2</sup>

[D149 Test Method for Dielectric Breakdown Voltage and Dielectric Strength of Solid Electrical Insulating Materials at Commercial Power Frequencies](#)

[D1711 Terminology Relating to Electrical Insulation](#)

[D5423 Specification for Forced-Convection Laboratory Ovens for Evaluation of Electrical Insulation](#)

2.2 *IEEE Document*<sup>3</sup>

[IEEE 101A Simplified Method for Calculation of the Regression Line](#)

## 3. Terminology

3.1 *Definitions:*

3.1.1 For definitions of terms used in this test method refer to Terminology [D1711](#).

3.2 *Definitions of Terms Specific to This Standard:*

3.2.1 *thermal endurance, n*—an expression for the stability of an electrical insulating material, or a simple combination of materials, when maintained at elevated temperatures for extended periods of time.

3.3 *Definitions*—For definitions of terms used in this test method refer to Terminology [D1711](#).

## 4. Summary of Test Method

4.1 Specimens are aged in air at a minimum of three temperatures above the expected use temperature of the material. Exposure to ambient stress conditions, followed by dielectric proof voltage tests in an electrically conductive solution, are periodically

<sup>1</sup> This test method is under the jurisdiction of ASTM Committee [D09](#) on Electrical and Electronic Insulating Materials and is the direct responsibility of Subcommittee [D09.01](#) on Electrical Insulating Products.

Current edition approved Nov. 1, 2018/Nov. 1, 2019. Published November 2018/November 2019. Originally approved in 2014. Last previous edition approved in 2014 as [D7895/D7895M – 14](#)/[D7895/D7895M – 14](#) (2018). DOI: [10.1520/D7895\\_D7895M-14R18-10.1520/D7895\\_D7895M-19](#).

<sup>2</sup> For referenced ASTM standards, visit the ASTM website, [www.astm.org](#), or contact ASTM Customer Service at [service@astm.org](#). For *Annual Book of ASTM Standards* volume information, refer to the standard's Document Summary page on the ASTM website.

<sup>3</sup> Available from Institute of Electrical and Electronics Engineers, Inc. (IEEE), 445 Hoes Ln., P.O. Box 1331, Piscataway, NJ 08854-1331, [http://www.ieee.org](#).

conducted to determine the time of aging at each elevated temperature required to reduce the breakdown voltage to a preselected percentage of the original breakdown value. These thermal life values are used to construct a thermal endurance graph by means of which it is possible to estimate a temperature index, corresponding to a thermal life as specified in the material specification or as agreed upon between the user and the supplier. It is possible that a material will have multiple indices, each corresponding to a different thermal life as required by a given application.

## 5. Significance and Use

5.1 A major factor affecting the life of insulating materials is thermal degradation. It is possible that other factors, such as moisture and vibration, will cause failures after the material has been weakened by thermal degradation.

5.2 Electrical insulation is effective in electrical equipment only as long as it retains its physical and electrical integrity. The following are potential indicators of thermal degradation: weight change, porosity, crazing, and generally a reduction in flexibility. Thermal degradation is usually accompanied by an ultimate reduction in dielectric breakdown.

5.3 This test method is useful in determining the thermal endurance of coating powders applied over a steel substrate material.

## 6. Apparatus

6.1 *Dielectric Breakdown Test Set*—The set shall meet the requirements of Test Method D149.

6.2 *Ovens*—Ovens shall meet the requirements of Specification D5423, Type I.

6.3 *Electrically Conductive Solution:*

6.3.1 An appropriate container shall be selected for the electrically conductive solution.

6.3.2 Prepare a solution having a conductivity of at least 2.5 mS (millisiemens).

NOTE 1—A solution comprised of tap water and a solute such as NaCl or NH<sub>4</sub>Cl has been found to be acceptable. Since the water solution is used to detect (not cause) material decomposition/breakdown, the solution is acceptable for use as long as it meets the minimum conductivity requirements. It is recommended to change the solution when it becomes difficult to observe breakdown due to cloudiness or other contamination.

6.3.3 During testing, the conductive solution is at ground potential. The ground connection, using an immersed electrode, is made using Nichrome, stainless steel, or other non-corrosive metal.

6.3.4 Fit the container with a cover to prevent evaporation of the solution when not in use.

## 7. Hazards

7.1 **Warning**—Lethal voltages are a potential hazard during the performance of this test. It is essential that the test apparatus, and all associated equipment electrically connected to it, be properly designed and installed for safe operation. Solidly ground all electrically conductive parts which are possible for a person to contact during the test. Provide means for use at the completion of any test to ground any parts which were at high voltage during the test, or have the potential for acquiring an induced charge during the test, or retaining a charge even after disconnection of the voltage source. Thoroughly instruct all operators as to the correct procedures for performing tests safely. When making high voltage tests, particularly in compressed gas or in oil, it is possible for the energy released at breakdown to be sufficient to result in fire, explosion, or rupture of the test chamber. Design test equipment, test chambers, and test specimens so as to minimize the possibility of such occurrences and to eliminate the possibility of personal injury. If the potential for fire exists, have fire suppression equipment available.

## 8. Test Specimens

8.1 The substrate material to be used for evaluating integral bus-bar insulation systems shall be steel. It is preferred that the configuration of the substrate material be representative of the end application. One configuration that has been found to be useful is shown in Fig. 1. Alternative configurations are acceptable if agreed to by all interested parties.

8.2 The substrate shall be coated with the powder and cured using the manufacturer's standard process. One end of the specimens shall be left uncoated for making an electrical connection during the dielectric strength tests.

## 9. Number of Test Specimens

9.1 A set of specimens for thermal aging shall consist of at least ten specimens. Prepare one set for each aging temperature chosen.

9.2 The initial value (unaged) set shall consist of at least twenty specimens.

9.3 The minimum number of test specimens is 50. It is recommended to prepare extra specimens for situations such as the need to add additional aging temperatures, or to have replacement specimens available for any specimens that are found during the screening test to be unsuitable for use in thermal aging.

## 10. Calibration and Standardization

10.1 Expose the test material to at least three aging temperatures. The preferred number of aging temperatures is four.

10.2 Minimum thermal life target values for the high and low temperatures shall be selected based on application.

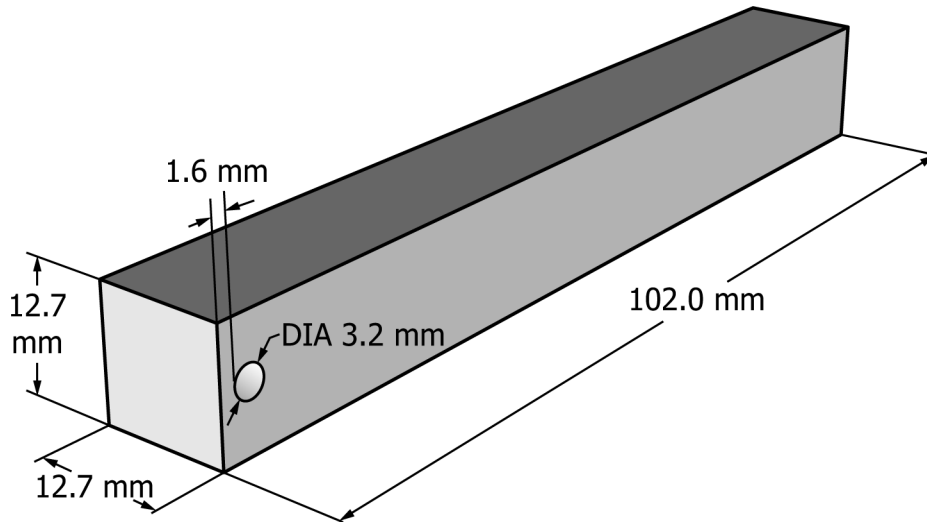

FIG. 1 Example Specimen Dimensions

10.3 Aging temperatures shall differ by at least  $\pm 10^{\circ}\text{C}$ .  $\pm 10^{\circ}\text{C}$ .

NOTE 2—Experience has shown that the suggested target thermal life values listed in Table 1 are generally satisfactory.

### 11. Selection of Aging Cycles

11.1 To provide approximately equal exposures to the other conditionings, and to more accurately determine the property endpoint, the heat aging time per cycle shall be shorter for the higher aging temperatures and longer for the lower aging temperatures.

11.2 Cycle times shall be selected such that each set undergoes an adequate (but not excessive) number of cycles before completion. In order to obtain an appropriate number of cycles, the following adjustments to the cycle time are recommended:

- 11.2.1 If no specimens in a set fail by the end of the 4<sup>th</sup> cycle, double the heat aging period of the test cycle.
- 11.2.2 If three or more specimens in a set fail by the end of the 4<sup>th</sup> cycle, halve the heat aging period of the test cycle.
- 11.2.3 Use observations in the highest temperature set to select appropriate adjustments to the other temperature sets.

NOTE 3—Experience has shown that the suggested cycle times in Table 1 are generally satisfactory.

### 12. Initial Value Test

12.1 To determine an initial dielectric strength level, at least twenty specimens shall be selected at random from the sample and subjected to a voltage breakdown test.

12.2 Connect one electrode of the tester to the uncoated end of the specimen. Suspend the coated end of the specimen in the electrically conductive solution described in 6.3.2 (see Fig. 2). The total surface area to be tested shall be sufficient to be representative of the intended application.

12.3 Apply voltage uniformly to the test electrode in accordance with the guidelines of the Short-Time Test described in 12.2.1 of Test Method D149, unless another rate is specified, until breakdown occurs.

12.4 Make one measurement on each specimen and compute the average dielectric breakdown voltage for the set. Record this as the initial value.

### 13. Screening Test

13.1 Prior to thermal aging, all specimens shall be subjected to a screening test in order to remove defective units. Any specimen that cannot pass the screening test shall be discarded and a replacement specimen selected for thermal aging.

13.2 Select a screening test voltage level that is a percentage of the average initial value.

TABLE 1 Suggested Cycle Times and Target Lives

Temperature Set	Cycle Time	Target Life
High Temperature	48–72 h	400–700 h
Middle High Temperature	168 h	1000–1500 h
Middle Low Temperature	336 h	2000–3000 h
Low Temperature	504 h	5000+ h