



Designation: **C1138M—12 C1138M – 19**

## Standard Test Method for Abrasion Resistance of Concrete (Underwater Method)<sup>1</sup>

This standard is issued under the fixed designation C1138M; the number immediately following the designation indicates the year of original adoption or, in the case of revision, the year of last revision. A number in parentheses indicates the year of last reapproval. A superscript epsilon ( $\epsilon$ ) indicates an editorial change since the last revision or reapproval.

### 1. Scope\*

1.1 This test method covers a procedure for determining the relative resistance of concrete (including concrete overlays and impregnated concrete) to abrasion under water (see **Note 1**). This procedure simulates the abrasive action of waterborne particles (silt, sand, gravel, and other solids).

NOTE 1—Other procedures are available for measuring abrasion resistance of concrete surfaces not under water. These include Test Methods **C418**, **C779/C779M**, and **E944C944/C944M**.

1.2 The values stated in SI units are to be regarded as standard. No other units of measurement are included in this standard.

1.3 The text of this standard references notes and footnotes that provide explanatory material. These notes and footnotes (excluding those in tables and figures) shall not be considered as requirements of this standard.

1.4 *This standard does not purport to address all of the safety concerns, if any, associated with its use. It is the responsibility of the user of this standard to establish appropriate safety, health, and environmental practices and determine the applicability of regulatory limitations prior to use. (Warning—Fresh hydraulic cementitious mixtures are caustic and may cause chemical burns to skin and tissue upon prolonged exposure.<sup>2</sup>)*

1.5 *This international standard was developed in accordance with internationally recognized principles on standardization established in the Decision on Principles for the Development of International Standards, Guides and Recommendations issued by the World Trade Organization Technical Barriers to Trade (TBT) Committee.*

### 2. Referenced Documents

2.1 *ASTM Standards:*<sup>3</sup>

**C42/C42M** Test Method for Obtaining and Testing Drilled Cores and Sawed Beams of Concrete

**C125** Terminology Relating to Concrete and Concrete Aggregates

**C418** Test Method for Abrasion Resistance of Concrete by Sandblasting

**C642** Test Method for Density, Absorption, and Voids in Hardened Concrete

**C670** Practice for Preparing Precision and Bias Statements for Test Methods for Construction Materials

**C779/C779M** Test Method for Abrasion Resistance of Horizontal Concrete Surfaces

**E944C944/C944M** Test Method for Abrasion Resistance of Concrete or Mortar Surfaces by the Rotating-Cutter Method

**E18** Test Methods for Rockwell Hardness of Metallic Materials

### 3. Terminology

3.1 For definitions of terms used in this standard, refer to Terminology **C125**.

### 4. Significance and Use

4.1 This test method is intended to qualitatively simulate the behavior of swirling water containing suspended and transported solid objects that produce abrasion of concrete and cause potholes and related effects.

4.2 This test method should provide a relative evaluation of the resistance of concrete to such action.

<sup>1</sup> This test method is under the jurisdiction of ASTM Committee **C09** on Concrete and Concrete Aggregates and is the direct responsibility of Subcommittee **C09.62** on Abrasion Testing.

Current edition approved Dec. 1, 2012; Oct. 1, 2019. Published January 2013; November 2019. Originally approved in 1989. Last previous edition approved in 2010; 2012 as **C1138M – 05 (2010) C1138M<sup>ε</sup> – 12**. DOI: 10.1520/C1138M-12-10.1520/C1138M-19.

<sup>2</sup> Section on Safety Precautions, *Manual of Aggregate and Concrete Testing, Annual Book of ASTM Standards*, Vol 04.02.

<sup>3</sup> For referenced ASTM standards, visit the ASTM website, www.astm.org, or contact ASTM Customer Service at service@astm.org. For *Annual Book of ASTM Standards* volume information, refer to the standard's Document Summary page on the ASTM website.

\*A Summary of Changes section appears at the end of this standard

4.3 The results are expected to be useful in selection of materials, mixtures, and construction practices for use where such action is to be expected.

4.4 The test method is not intended to provide a quantitative measurement of the length of service that may be expected from a specific concrete.

**5. Apparatus**

5.1 *Rotating Device*—A drill press or similar device with a chuck capable of holding and rotating the agitation paddle under test conditions at a speed of  $1200 \pm 100$  rpm shall be used.

5.2 *Test Container*—A steel pipe,  $305 \pm 6$ -mm ( $12 \pm 1/4$ -in.) inside diameter by  $450 \pm 25$ -mm ( $18 \pm 1$ -in.) high, fitted with a watertight steel base shall be used (see Fig. 1).

5.3 *Agitation Paddle*—The agitation paddle shall be as shown in Fig. 2.

5.4 *Abrasive Charges*—Seventy grade 1000 chrome steel grinding balls with nominal sizes as specified in Table 1 shall be used. The steel of which the balls are made shall have a Rockwell C-scale hardness of  $65 \pm 5$  as determined by Test Methods E18. The balls shall have a smooth texture and no apparent mold seam (see Note 2).

NOTE 2—An abrasive charge meeting the requirements of Table 1 will have a mass of approximately 1530 to 1900 g (3.8 to 4.2 lb). When the mass of the charge approaches the lower limit, replace the undersize or underweight balls not complying with Table 1.

5.5 *Scales*—A platform scale having a capacity of at least 45 kg (100 lb) or more and accurate to within at least 5.0 g (0.01 lb) at any point within the range used in this test shall be used. The scale shall be equipped with a suitable apparatus for suspending the sample in its container in water from the center of the weighing platform.

5.6 *Weighing Basket*—A wire basket or other suitable support shall be provided for weighing the specimen in water. The weighing basket shall be constructed to prevent entrapping air when it and the specimen are submerged.

5.7 *Water Tank*—A suitable watertight tank into which the basket and the specimen can be suspended below the scale shall be furnished.

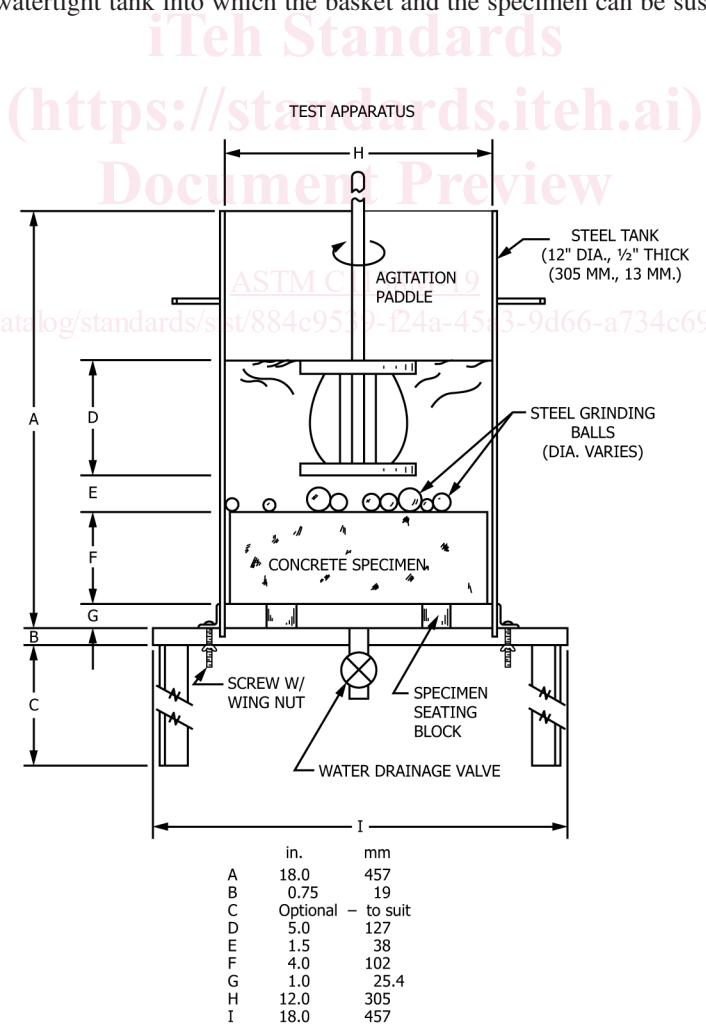
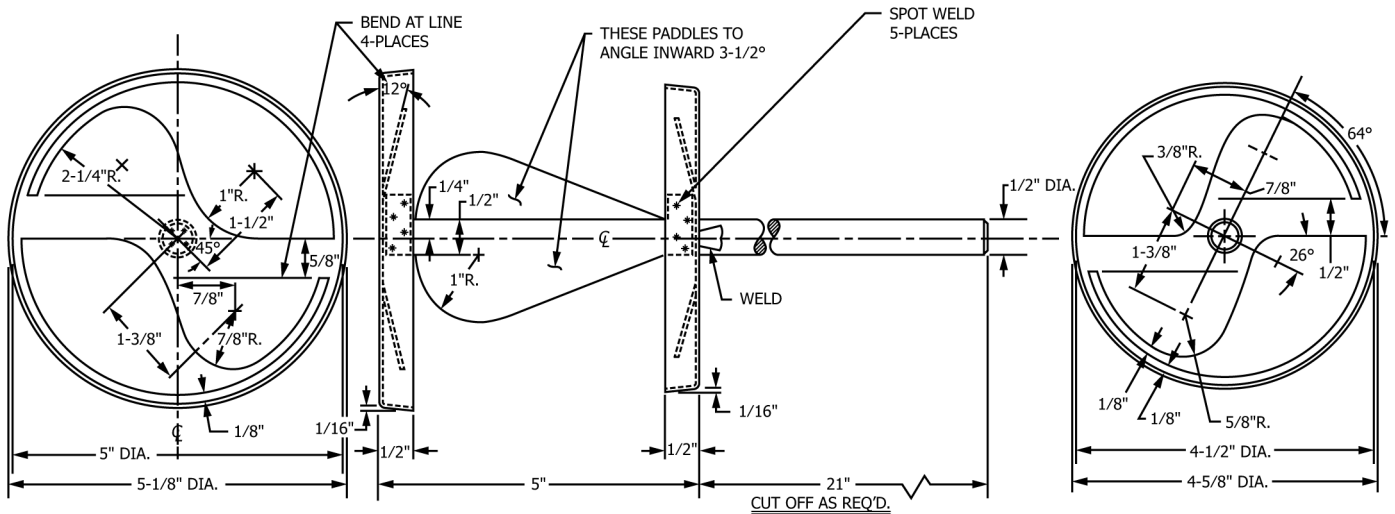

FIG. 1 Test Apparatus



NOTE 1—1—16 Ga (0.059 in.)—304 Stainless Steel  
 NOTE 2—Rotation of agitation paddle clockwise when viewed from shaft end.  
 NOTE 3—Shaft length to be adjusted to fit assembly in Fig. 1.

in.	mm
21	533
5 1/8	130
5	127
4 5/8	117
4 1/2	114
3 9/16	97
2 1/4	57
1 1/2	38
1 3/8	35
1	25
7/8	22
5/8	16
1/2	13
3/8	10
1/4	6
1/8	3
1/16	2

TOLERANCE UNLESS OTHERWISE SPECIFIED	Material 16 GA.(.059) STEEL	FINISH	TITLE		
			REVISIONS	BY	DATE
					AGITATION PADDLE

FIG. 2 Agitation Paddle

TABLE 1 Abrasive Charges

Number of Balls	Nominal Size	Minimum Diameter
10	1.00 in.	25.3 mm (0.95 in.)
35	0.75 in.	19.0 mm (0.70 in.)
25	0.50 in.	12.6 mm (0.45 in.)

5.8 Seating Block—A minimum of three steel blocks 25 by 25 by 25 mm (1 by 1 by 1 in.) shall be used to support the specimen.

## 6. Test Specimens

6.1 The test specimen shall be cylindrical in shape, having a diameter approximately 6-mm (1/4-in.) less than that of the inside diameter of the test container and a height of 100 ± 13 mm (4 ± 1/2 in.). It may be molded from freshly mixed concrete or cored from hardened concrete (see Note 3). Cores shall be taken in accordance with Methods C42/C42M.

NOTE 3—Specimens should be tested at an age appropriate for the material being evaluated. Most testing done to date has been done at 28 days. Concretes containing pozzolans should be tested at an age that allows development of appropriate strength. Toppings and impregnated concretes should be tested at an age appropriate for the material and in compliance with the manufacturer's recommendations. The appropriate testing age may also depend upon when the concrete will be put into service.

6.2 If the specimen has a membrane curing compound on the surface, remove it completely by steel wire brushing prior to the soaking period.