



# Standard Specification for Eye Protective Devices for Paintball Sports<sup>1</sup>

This standard is issued under the fixed designation F1776; the number immediately following the designation indicates the year of original adoption or, in the case of revision, the year of last revision. A number in parentheses indicates the year of last reappraisal. A superscript epsilon ( $\epsilon$ ) indicates an editorial change since the last revision or reappraisal.

## INTRODUCTION

This is the specification for eye, face, and head protective devices, or EHPD, to be used in the sport of paintball. Paintball is a sport that, like all sports, has intrinsic hazards. These hazards include being hit by paintballs. Protective equipment cannot eliminate all injuries but will substantially reduce their severity and frequency. Participation in this sport by a player implies acceptance of injury risk. The goal of protective equipment is to minimize the risk of injury.

Performance requirements are presented and are intended to minimize injury with minimal impairment of the form and appeal of the sport. This specification is subject to revision as indicated by subsequent injury statistics.

The impact requirements are designed to give eye, adnexa of eye, and head protection from paintball impacts likely to be encountered under game conditions. While the EHPD also may protect the user from other potential impacts, such as running into tree branches, there are many conceivable impacts, including falls from heights, which could exceed the specification and result in eye injury despite the use of the EHPD.

## 1. Scope

1.1 This specification applies to eye, face, and head protective devices, designed for use by players of the sport of paintball, which minimize or significantly reduce injury to the eye, adnexa of eye, face, and head due to paintball impact or penetration, or both.

1.2 EHPDs by nature provide three types of protection. The first type of protection is for the eyes and adnexa of eye and not necessarily for any other parts of the face or head. The second type of protection adds coverage for the ears and face. The third type of coverage adds cranial coverage in addition to that provided to types II and III. These coverage types are defined in Section 8.

<https://standards.iteh.ai/catalog/standards/sist/43e81dc1-ecce8-4c57-8441-0b80a1e2ca87/astm-f1776-19>

1.3 This specification does not limit the wearing of eyeglasses or contact lenses when used in conjunction with the EHPD.

1.4 The values stated in SI units are to be regarded as the standard. The values given in parentheses are for information only.

1.5 *This standard does not purport to address all of the safety concerns, if any, associated with its use. It is the responsibility of the user of this standard to establish appropriate safety, health, and environmental practices and determine the applicability of regulatory limitations prior to use.*

1.6 *This international standard was developed in accordance with internationally recognized principles on standardization established in the Decision on Principles for the Development of International Standards, Guides and Recommendations issued by the World Trade Organization Technical Barriers to Trade (TBT) Committee.*

## 2. Referenced Documents

2.1 *ASTM Standards:*<sup>2</sup>

[E1027 Test Method for Determining Visible Abrasion Resistance of Glazed Ceramic Tile](#)

[D1003 Test Method for Haze and Luminous Transmittance of Transparent Plastics](#)

<sup>1</sup> This specification is under the jurisdiction of ASTM Committee F08 on Sports Equipment, Playing Surfaces, and Facilities and is the direct responsibility of Subcommittee F08.57 on Eye Safety for Sports.

Current edition approved July 1, 2018; Nov. 15, 2019. Published July 2018; December 2019. Originally approved in 1997. Last previous edition approved in 2016 as F1776 – 16; F1776 – 18. DOI: 10.1520/F1776-18; 10.1520/F1776-19.

<sup>2</sup> For referenced ASTM standards, visit the ASTM website, www.astm.org, or contact ASTM Customer Service at service@astm.org. For *Annual Book of ASTM Standards* volume information, refer to the standard's Document Summary page on the ASTM website.

[F803 Specification for Eye Protectors for Selected Sports](#)  
[F1979 Specification for Projectiles Used in the Sport of Paintball](#)  
[F2272 Specification for Paintball Markers](#)

2.2 *ANSI Standards:*

[ANSI Z80.3 Requirements for Nonprescription Sunglasses and Fashion Eyewear](#)<sup>3</sup>  
[ANSI Z87.1 Practice for Occupational and Educational Eye and Face Protectors](#)<sup>3</sup>

2.3 *CSA Standard:*<sup>4</sup>

[CSA Z262.6-02 Specifications for Facially Featured Headforms](#)  
[CSA Z262.6-14 Specifications for Facially Featured Head Forms](#)

2.4 *EN Standard:*<sup>5</sup>

[EN 168 Personal Eye Protection – Non-Optical Test Method - Section 17 Headforms](#)

2.5 *Federal Standards:*<sup>6</sup>

No. 406  
 No. 3022

### 3. Terminology

3.1 *Definitions of Terms Specific to This Standard:*

3.1.1 *adnexa, n*—adjunct parts of the eye, including the orbit, orbital contents, eyelids, and the lacrimal apparatus.

3.1.2 *astigmatism, n*—a condition in a lens that creates two axially separated line foci of each object point, the lines being mutually perpendicular. In other words, the lens has two different refractive powers in meridians that are 90° apart.

3.1.3 *base-in, adj*—relating to the type of prism imbalance that tends to cause parallel rays of light passing through an EHPD, spaced apart by the interpupillary distance, to converge.

3.1.4 *base-out, adj*—relating to the type of prism imbalance that tends to cause parallel rays of light passing through an EHPD, spaced apart by the interpupillary distance, to diverge.

3.1.5 *binocular, adj*—relating to the field of view that is shared by both eyes simultaneously.

3.1.6 *caliber, n*—the term used to refer to the size of a paintball projectile. Related to the measurement of the diameter of the paintball.

3.1.7 *central viewing zone, n*—that part of a lens that has its center in line with the wearer’s line of sight when looking straight ahead. The zone is circular in shape. For the purpose of this specification, it shall be considered to be 38 mm in diameter. The center of the central viewing zone shall be the point of intersection of the line of sight with the lens as mounted on the headform, specified by the manufacturer.

3.1.8 *cleanable, adj*—the ability of an EHPD to be made readily free of dirt or grime without being damaged during an appropriate cleaning process, such as the use of soap and water.

3.1.9 *corneal apex, n*—The most anterior point of the cornea when the eye is in the primary position.

3.1.10 *coverage, n*—those areas of the eye, face, and head as covered by the EHPD as defined in 8.3.

3.1.11 *definition, optical, n*—the characteristic of a lens that allows separate distinct points in close proximity to be discerned when looking through the lens.

3.1.12 *dislodge, v*—remove or force an object from its original position.

3.1.13 *eye, n*—relating to the eye of the headform or the eye of a person wearing an EHPD or that part of an EHPD through which a wearer’s eye would normally look.

3.1.14 *eye of the headform, n*—all structures contained within the orbital rim of the specified headform.

3.1.15 *EHPD, n*—device that provides protection to the wearer’s eyes, face, and head against paintball impact or penetration, or both.

3.1.16 *haze, n*—the fraction of the total transmitted light from a normally incident beam that is not transmitted in a focused condition but scattered by inclusions or surface defects. Excessive haze will reduce contrast and visibility.

3.1.17 *headform, n*—as utilized within this standard for the as-worn assessment of EHPDs, key dimensions of which are as provided in [CSA Z262.6-02](#) or [EN 168](#); [Z262.6-02](#), EN 168, or [CSA Z262.6-14](#) except with an adjusted durometer (hardness) of 50 ± 5.5 Shore A.

3.1.18 *lens, n*—transparent part of an EHPD through which the wearer normally sees.

<sup>3</sup> Available from American National Standards Institute (ANSI), 25 W. 43rd St., 4th Floor, New York, NY 10036, <http://www.ansi.org>.

<sup>4</sup> Available from Canadian Standards Association (CSA), 5060 Spectrum Way, Mississauga, ON L4W 5N6, Canada, <http://www.csa.ca>.

<sup>5</sup> Available from European Committee for Standardization (CEN), Avenue Marnix 17, B-1000, Brussels, Belgium, <http://www.cen.eu>.

<sup>6</sup> Available from Standardization Documents Order Desk, Bldg. 4 Section D, 700 Robbins Ave., Philadelphia, PA 19111-5094, Attn: NPODS.

### 3.1.18.1 Discussion—

The most common configurations for lenses are single pane and thermal double pane. Thermal double pane lenses are usually constructed from a single pane lens which has a second clear airtight thermal barrier affixed to it to reduce the effects of lens fogging. Some lenses also are treated with chemical solutions to reduce lens fogging.

3.1.19 *lens retention component(s)*, *n*—components, separate from the lens, that are designed to retain the lens in the frame or body of the EHPD.

3.1.20 *luminous transmittance*, *n*—luminous transmittance is a function of the spectral transmittance of the lens weighted by the corresponding ordinates of the photopic luminous efficiency distribution of the CIE (1931) standard colorimetric observer and by the spectral intensity of standard Illumination C (see ANSI Z80.3).

3.1.21 *paintball*, *n*—~~spherical ball~~, projectile comprised of a shell and a fill manufactured in accordance with the requirements of Specification **F1979** and designed to be expelled from a paintball marker.

3.1.22 *paintball fragment*, *n*—a part of the shell of the paintball that will not be surrounded completely by a 3 by 5-mm rectangle.

3.1.23 *paintball marker*, *n*—device specifically designed to discharge paintballs which conforms with Specification **F2272**.

3.1.24 *orbital area*, *n*—the area contained in a circle  $r = 20$ -mm centered on the pupil of the specified headform.

3.1.25 *power imbalance*, *n*—a condition that exists when the refractive power created by the right lens of the EHPD is different from that of the left lens.

3.1.26 *prism*, *n*—the angular deviation of a ray of light as it passes through a lens resulting from the angle at which the ray strikes each surface of the lens and the index of refraction of the material from which it is made.

3.1.27 *prism imbalance*:

3.1.27.1 *horizontal imbalance*, *n*—the difference in prismatic deviation of incident parallel light beams on the two eyes of an EHPD in the horizontal meridian (see **base-in** and **base-out**).

3.1.27.2 *vertical imbalance*, *n*—the difference in prismatic deviation between parallel light beams incident on the two eyes of an EHPD in the vertical meridian.

3.1.28 *refractive power*, *n*—the focusing effect of a lens expressed in diopters.

3.1.29 *spherical power*, *n*—the average of the maximum meridional astigmatic power and the minimum meridional astigmatic power of a lens.

## 4. Performance Requirements

### 4.1 Optical Requirements:

4.1.1 *Field of View*—When tested in accordance with **6.1**, the basic EHPD, without any accessories such as a sun visor installed, shall have a field of view equal to or exceeding the following:

4.1.1.1 *Temporal Field*— $50^\circ$ .

4.1.1.2 *Nasal Field*— $30^\circ$ .

4.1.1.3 *Superior Field*— $30^\circ$ .

4.1.1.4 *Inferior Field*— $30^\circ$ .

4.1.2 *Refractive Tolerances*—When tested in accordance with **6.6**, the spherical power shall not be less than  $-0.37$  diopters and shall not exceed  $+0.06$  diopters.

4.1.3 *Astigmatism*—When tested in accordance with **6.6**, the astigmatism shall not exceed  $0.25$  diopters.

4.1.4 *Power Imbalance*—When tested in accordance with **6.6**, the power imbalance in corresponding meridians between the two eyes for straight ahead seeing shall not exceed  $0.18$  diopters.

4.1.5 *Prism*—When tested in accordance with **6.4** or **6.8**, the primary viewing position of either eye of a shield shall not exceed  $0.5$  prism diopters.

4.1.6 *Prism Imbalance*—When tested in accordance with **6.4** or **6.8**, the prism imbalance shall meet the following criteria:

4.1.6.1 *Vertical Imbalance*, shall not exceed  $+0.25$  diopters.

4.1.6.2 *Horizontal Imbalances*—Negative values (base-in) shall not be less than  $-0.25$  prism diopters, and positive values (base-out) shall not be more than  $+1.0$  prism diopters.

4.1.7 *Luminous Transmittance*—When tested in accordance with **6.3**, the luminous transmittance shall not be less than  $60\%$  for clear lenses and not less than  $17\%$  for tinted lenses unless labeled very dark in which case the minimum transmittance shall be no less than  $8\%$ .

4.1.8 *Haze*—When tested in accordance with **6.5**, the haze of the EHPD lens shall not exceed  $3\%$ .

4.1.9 *Optical Quality*—Within the central viewing zone, striae, warpage, surface ripples, or other defects that are apparent under the optical inspection test conditions of **6.2** shall be considered a failure. An exception is when small specks or inclusions, which are not seen when the lens is held close to the eye in the as-worn position, shall not be a cause of rejection.

4.1.10 *Physical Lens Defects*—Within the central viewing zone, pits, scratches, grayness, bubbles, cracks, water marks, or other defects that are apparent under the visible inspection test conditions of 6.7 shall be considered a failure. An exception that small specks or inclusions, which are not seen when the lens is held close to the eye in the as-worn position, shall not be cause of rejection.

4.2 *Mechanical Requirements:*

4.2.1 When tested in accordance with Section 7, the basic EHPD, without any accessories such as a sun visor installed:

4.2.1.1 No contact by components of the EHPD or paintball fragments is allowed with the orbital area of the selected headform.

4.2.1.2 Any visible fracture of the lens, frame, or EHPD constitutes a failure.

4.2.1.3 Any dislodging of the lens from the frame constitutes a failure.

4.2.1.4 Any dislodging of a lens retention component from the EHPD constitutes a failure.

4.2.1.5 Any dislodging of a component of the EHPD that would permit free passage and contact of a 5-mm diameter probe ( $\pm 0.1$  mm) to the orbital area of the selected headform constitutes failure.

4.2.1.6 Any contact of an intact paintball, on the portion of the selected headform protected by the EHPD, after said paintball penetrated or passed through the protective portion of the EHPD, constitutes failure.

4.2.1.7 Any rotation of the headgear system on the selected headform that would permit free passage and contact of a 5-mm diameter probe ( $\pm 0.1$  mm) to the orbital area of the selected headform constitutes failure.

## 5. Sample Preparation

5.1 *Eye and Head Protective Devices:*

5.1.1 Only new and complete EHPDs as offered for sale shall be tested.

5.1.2 EHPDs shall be subjected to a single impact test.

5.1.3 The EHPD shall be conditioned for a minimum of 4 h at the specified temperature prior to each test.

5.2 *Test Temperatures:*

5.2.1 *Cold Test*,  $-12.2^{\circ}\text{C} \pm 2^{\circ}\text{C}$  ( $10^{\circ}\text{F} \pm 3.5^{\circ}\text{F}$ ).

5.2.2 *Room Temp*,  $23^{\circ}\text{C} \pm 2^{\circ}\text{C}$  ( $73^{\circ}\text{F} \pm 3.5^{\circ}\text{F}$ ).

5.2.3 *Hot Test*,  $37.8^{\circ}\text{C} \pm 2^{\circ}\text{C}$  ( $100^{\circ}\text{F} \pm 3.5^{\circ}\text{F}$ ).

5.3 *Paintballs:*

5.3.1 All impact testing shall be done using 68 caliber paintballs manufactured in accordance with the requirements of Specification F1979 and obtained within 30/270 days of the testing date. The paintball bulk container shall be resealed immediately after each group of paintballs is removed. Paintball storage and nontest handling shall be done at a relative humidity below 55 % and at a temperature between 12.7 and 29°C (55 and 85°F).

5.3.2 Paintballs used for impact testing shall be conditioned in a sealed packet (bag) for at least 4 h at the specified temperature for each test. Impact testing shall be completed within 3 min after removal of the paintballs from their temperature conditioning atmosphere.

5.4 *Headform*—The manufacturer shall normally specify to the testing facility the type and size of headform to be used for testing within this standard. This selection shall be based upon the design and size of the EHPD. In the case where the manufacturer does not specify a specific headform or size the CSA Z262.6-02 Adult Male headform shall be considered the default choice. testing lab may select the headform based on the best fit as would normally be worn by the user and secure in accordance with the manufacturer's instructions.

## TEST METHODS

### 6. Optical Test Methods

6.1 *Field of View (Angle of Vision):*

6.1.1 *Purpose*—This test method is intended to determine the relative unobstructed angle visually available to the user. With the EHPD mounted on the standard headform, the corneal apex should be visible to an observer when sighted from the required field angles in accordance with 4.1.1. Any sighting method may be used. Paragraphs 6.1.2 – 6.1.4 give one method.

6.1.2 *Apparatus*—The concept is to mount a CSA-headform, size specified by the manufacturer or chosen by the test lab, in a gimbal. Any gimbal that is sufficiently large and sturdy and properly inscribed with horizontal and vertical protractor markings is acceptable. Figs. 1-3 show front and side vertical schematic views of a wooden gimbal that can be constructed with simple tools. Item A is the base and support for horizontal rotation. A protractor shall be marked on the base with its center coincident with the axis of rotation. Base A shall protrude forward to allow for the protractor markings. These indicate the position of B. Item B comprises the main carriage of the gimbal. Item C comprises the vertically rotating member. Sections CR and CL are the right and left vertical supports. Fig. 2 shows the horizontal view. A window in the left of the vertical B support makes the protractor markings on section CL visible for accurate setting. Section CL can be pie-shaped, providing that a 60° angle can be read. The markings shall be made every 5° and marked every ten. A set screw shall be threaded into the B section or a ¼-20 nut can be inlaid if section B is wooden. Ensure that ¼-20 thumb screws are available readily for use as the set screw.

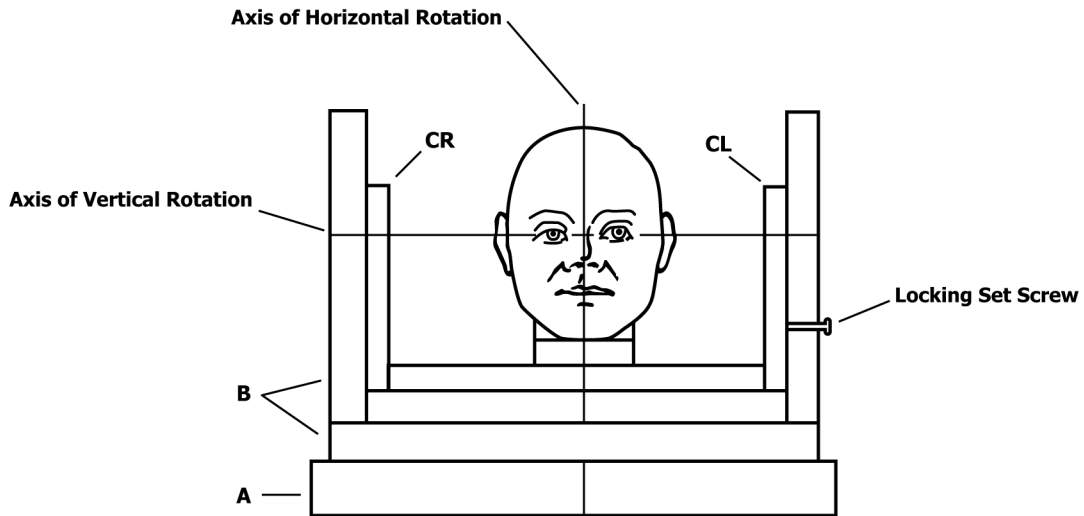

FIG. 1 Schematic of Gimbal for Supporting Standard Head

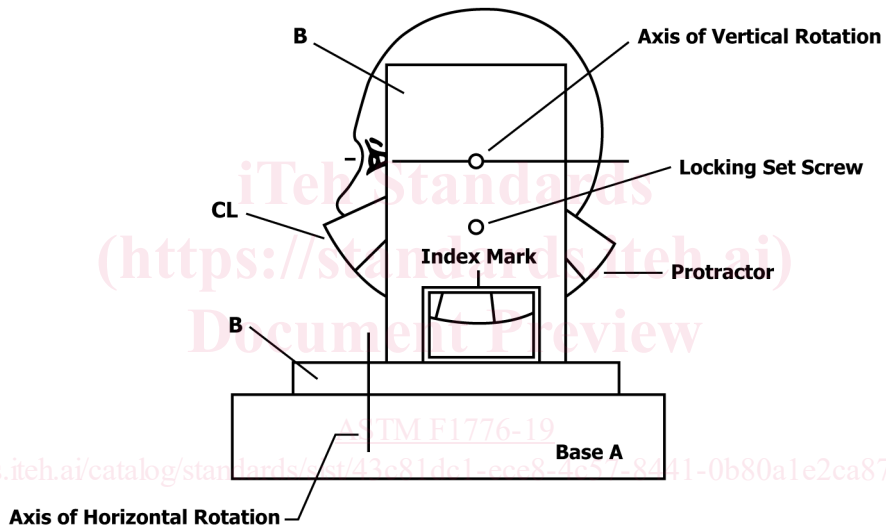

FIG. 2 Side View of Gimbal

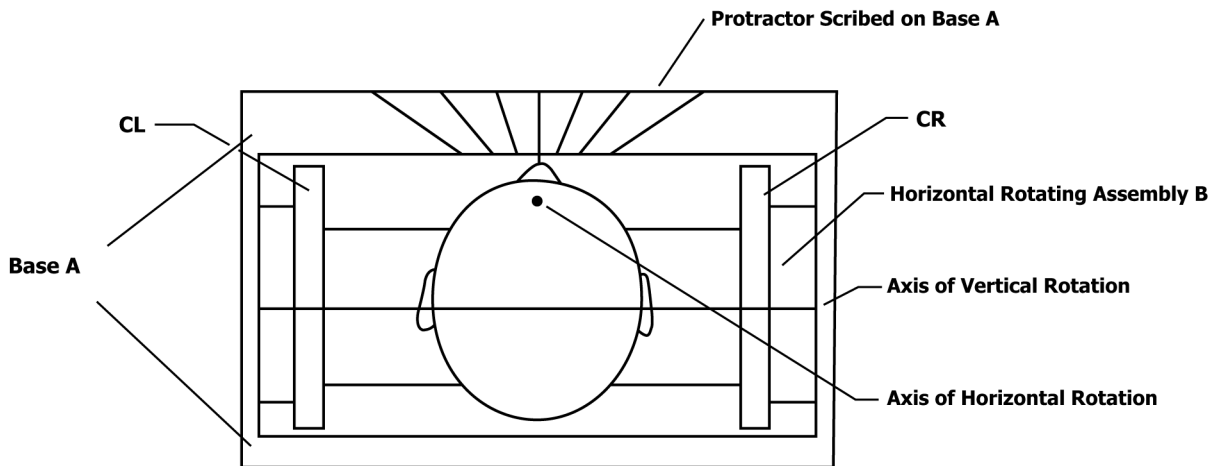

FIG. 3 Top View Showing Base for Horizontal Rotation

The location of the standard head shall should be planned to obtain a good balance for vertical rotations. The horizontal rotation axis shall be in the plane of the corneas. The axis themselves can be 12-mm (1/2-in.) dowels or 6-mm (1/4-in.) metal rods. Fig. 3



shows the location of the pivots for their respective rotations. Fig. 4 shows an example of a test setup. The total path from gimbal to the eye, camera, or light source shall be at least 7.31 m (24 ft). Using a mirror facilitates adjusting the gimbal while observing the position of the corneas in the protector. A low power telescope or simply a monocular eye locating ring or washer can be substituted for the video camera. The corneas shall be painted white or covered with white or reflecting tape in the form of an 8-mm disk. A high level ambient light is desirable. Visual optics may be replaced with photo detectors in the corneas having separate readout means for the two eyes. A strong light source would replace the video camera in which case a low level of ambient light is desirable. A collimating lens would increase the signal to noise ratio of the photo-detectors. The set up as indicated in the drawing introduces a horizontal angle of error of  $-0.2^\circ$  and a vertical angle of error of approximately  $-0.6^\circ$  at  $60^\circ$ . The location of the vertical angle of tip is centered in the headform to help balance the gimbal. These errors can be accounted for in the decision process. A longer path between the input and output devices will decrease the errors proportionately.

6.1.3 *Test Procedure*—Mount the EHPD to be tested on the headform in the intended wearing position. Set the gimbal in the straight ahead position and verify the visibility of metered response of the two eyes. The gimbal then is rotated to determine the horizontal and vertical extreme angles of view in all four directions along which the appropriate corneas can be seen monocularly.

6.1.4 *Report*—Record and report the maximum angles of view in all four directions.

6.2 *Optical Quality*—Localized power errors or aberrations that are detected by the visual inspection procedure of 6.2.1 are permissible if no measurable or gross foci meter or telescope target distortion or blur is found when the localized area is examined with an instrument as indicated in 6.2.2.

6.2.1 *Inspection Procedure*—One method of optical inspection is to view a high-contrast grid pattern of dark and white lines through the lens, scanning it area by area and moving it about. The grid pattern shall be at least 45 by 45 cm (18 by 18 in.) and constructed of high contrast black lines on a white background (the white separations being equal to the black lines, both being approximately 6 mm [ $\frac{1}{4}$  in.] wide). The target shall be at least 1.8 to 2.5 m (6 to 8 ft) from the observer, and the lens shall be held at least 45 to 60 cm (18 to 24 in.) from the eye. Any ripples in the lens detected by this test method shall be further examined in accordance with 6.2.2.

6.2.2 The referee method of detecting optical defects and local aberrations is to scan the central viewing zone, especially areas of suspicion arising from the visual test of 6.2.1. The lens of shield shall be scanned with a precision foci meter or an 8 to 10 $\times$  telescope using the targets and arrangements described in 6.6.2 – 6.6.3.2. The aperture shall be 5 to 7 mm for this examination. Areas outside the central viewing zone or within 6 mm of the edge need not be tested. When the central viewing area is scanned, there shall be no sudden jump, doubling, or blurring of the image greater than 0.08 diopters change in power. Gradual variations in the central viewing zone shall be within the power imbalance tolerances. An optical foci meter with electronic readout repeatable to 0.02 diopters is a satisfactory alternate method. These scanning procedures may be made by scanning across the lens surface not necessarily in the “as worn” mode.

6.3 *Luminous Transmittance*—Use a suitable photometer, such as a Gardner Hazemeter, or other device comprised of a light source of CIE Illuminant C at 6774° K color temperature and a photometric probe and meter capable of reading transmission in percent over a range from 1 to 100 %. Use a suitable enclosure to block against stray light and contain the test samples. Following the manufacturers instruction for the use of the instrument, measure the specimen for percent transmittance within each of the two central viewing zones. The measured values shall meet the established criteria for the device. A spectrophotometer, followed by appropriate photometric calculation, also may be used.

6.3.1 For the purposes of this specification, luminance transmittance may be measured with inexpensive photometers. A fixturing device shall be devised to exclude ambient light. The source need not be strictly Illuminate C. A tungsten lamp or a screw-in fluorescent lamp provides adequate simulation of the use environment.

6.4 *Prismatic Deviation Measurements:*

6.4.1 *Purpose*—This test is intended to measure the angular deviation of light rays created by the EHPD as they pass through the lens(es).

6.4.2 *Apparatus*—A telescope, equipped with a cross hair reticule having a magnification of 8 $\times$  to 10 $\times$  and an aperture 19 mm in diameter shall be used. The test method outlined in ANSI Z87.1 has been found satisfactory for this purpose. Other methods that yield comparable results may be used. For this test method, the target distance is 4 m. This target is easier to achieve than

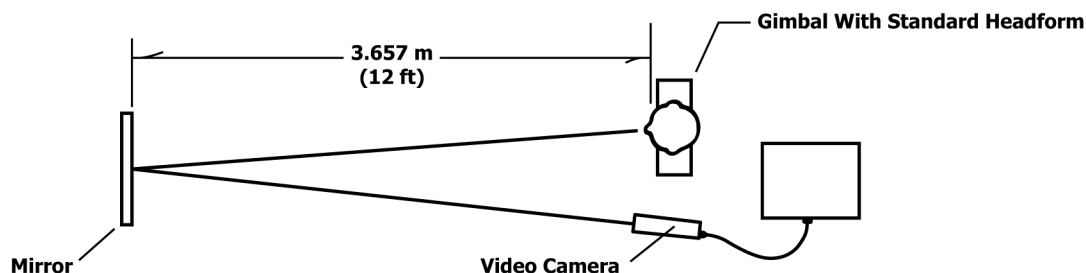

FIG. 4 Bench-Top Field-of-View Setup