



Designation: D3806 – 19a

# Standard Test Method of Small-Scale Evaluation of Fire-Retardant Paints (2-Foot Tunnel Method)<sup>1</sup>

This standard is issued under the fixed designation D3806; the number immediately following the designation indicates the year of original adoption or, in the case of revision, the year of last revision. A number in parentheses indicates the year of last reapproval. A superscript epsilon ( $\epsilon$ ) indicates an editorial change since the last revision or reapproval.

## 1. Scope

1.1 This test method determines the protection a coating affords its substrate, and the comparative burning characteristics of coatings by evaluating the flame spread over the surface when ignited under controlled conditions in a small tunnel. This establishes a basis for comparing surface-burning characteristics of different coatings without specific consideration of all the end-use parameters that might affect surface-burning characteristics under actual fire conditions.

1.2 In addition to the experimental flame spread rate, the weight of panel consumed, time of afterflaming and afterglow, char dimensions and index, and height of intumescence can be measured in this test. However, a relationship should not be presumed among these measurements.

1.3 This standard is used to determine certain fire-test responses of materials, products, or assemblies to heat and flame under controlled conditions by using results obtained from fire-test response standards. The results obtained from using this standard do not by themselves constitute measures of fire hazard or fire risk.

1.4 The values stated in SI units are to be regarded as the standard. The values given in parentheses are for information only.

1.5 *This standard is used to measure and describe the response of materials, products, or assemblies to heat and flame under controlled conditions, but does not by itself incorporate all factors required for fire hazard or fire risk assessment of the materials, products, or assemblies under actual fire conditions.*

1.6 *Fire testing is inherently hazardous. Adequate safeguards for personnel and property shall be employed in conducting these tests.*

1.7 *This standard does not purport to address all of the safety concerns, if any, associated with its use. It is the responsibility of the user of this standard to establish appro-*

*priate safety, health, and environmental practices and determine the applicability of regulatory limitations prior to use.*

1.8 *This international standard was developed in accordance with internationally recognized principles on standardization established in the Decision on Principles for the Development of International Standards, Guides and Recommendations issued by the World Trade Organization Technical Barriers to Trade (TBT) Committee.*

## 2. Referenced Documents

2.1 *ASTM Standards:*<sup>2</sup>

**D344** Test Method for Relative Hiding Power of Paints by the Visual Evaluation of Brushouts (Withdrawn 2018)<sup>3</sup>

**D1475** Test Method for Density of Liquid Coatings, Inks, and Related Products

**D2196** Test Methods for Rheological Properties of Non-Newtonian Materials by Rotational Viscometer

**E84** Test Method for Surface Burning Characteristics of Building Materials

2.2 *Federal Standard:*

**Fed. Spec. TT-V-119** Varnish, Spar, Phenolic Resin<sup>4</sup>

## 3. Significance and Use

3.1 A number of laboratory procedures are used to evaluate the effectiveness of fire-retardant and fire-resistant treatments and coatings. In general, these methods measure the three stages of fire development: (1) ignition; (2) flame spread (rate of growth of the fire); and (3) conflagration extent. While all three are of extreme importance, flame spread has been recognized as the main factor associated with testing fire-retardant coatings.

3.2 Flame spread ratings based upon Test Method **E84** have acquired common acceptance by regulatory agencies, but such

<sup>2</sup> For referenced ASTM standards, visit the ASTM website, [www.astm.org](http://www.astm.org), or contact ASTM Customer Service at [service@astm.org](mailto:service@astm.org). For *Annual Book of ASTM Standards* volume information, refer to the standard's Document Summary page on the ASTM website.

<sup>3</sup> The last approved version of this historical standard is referenced on [www.astm.org](http://www.astm.org).

<sup>4</sup> Available from DLA Document Services, Building 4/D, 700 Robbins Ave., Philadelphia, PA 19111-5094, <http://quicksearch.dla.mil>.

<sup>1</sup> This test method is under the jurisdiction of ASTM Committee **D01** on Paint and Related Coatings, Materials, and Applications and is the direct responsibility of Subcommittee **D01.21** on Chemical Analysis of Paints and Paint Materials.

Current edition approved Dec. 1, 2019. Published December 2019. Originally approved in 1979. Last previous edition approved in 2019 as D3806 – 19. DOI: 10.1520/D3806-19A.

large-scale tests are seldom practical during the development or modification of a fire-retardant coating.

3.3 This test method provides the relative flame spread of experimental coatings using small test specimens under the conditions established in the 2-foot tunnel. By experimentally calibrating the 2-foot tunnel with similar Test Method E84-rated fire-retardant paint, results obtained by this test method can be used to screen coatings for suitability for testing in the Test Method E84 tunnel.

3.3.1 This test method is intended as an experimental tool in evaluating experimental coatings for further development. No direct correlation of results from this test method and the Test Method E84 tunnel have been made or are implied.

3.3.2 The results obtained by this test method do not in themselves act as an accurate predictor of performance in Test Method E84 and shall not be used for the purpose of certification to any class of flame spread performance.

**4. Apparatus**

4.1 *Flame Tunnel* (see Fig. 1A)—610-mm (two-foot) flame tunnel consisting of asbestos-free cement board mounted on a steel or stainless steel framework and supplied with methane fuel of uniform quality.

4.1.1 The framework is constructed of 3 by 25 by 25-mm (1/8 by 1 by 1-in.) steel or stainless steel, the top of which provides a 610 by 100-mm (24 by 4-in.) specimen holder inclined at 28° to the horizontal. The framework is mounted on a 250 by 610 by 13-mm (10 by 24 by 1/2-in.) steel or stainless steel base. The specimen holder is elevated 185 mm (7 3/8 in.) above the base at the lower (fire) end and 480 mm (18 7/8 in.) at the upper (flue) end.

4.1.2 The fire end and sides of the tunnel are covered to the extent shown in Fig. 1, with 6-mm (1/4-in.) asbestos-free cement board or 6-mm (1/4-in.) inorganic asbestos-free reinforced-cement board attached to the inside of the framework. The open flue end and the cut-out sides allow a natural draft through the tunnel. Additional air access is provided by a 25-mm (1-in.) hole drilled in the cover at the fire end, centered and 115 mm (4 1/2 in.) above the base.

4.1.3 An observation window made of a 50-mm (2-in.) wide strip of 3-mm (1/8-in.) polished heat-resistant sheet glass<sup>5</sup> is located just below the specimen holder, extending the full length of the tunnel, 610 mm (24 in.). This glass is marked by any appropriate method at 1-in. intervals from 4 to 22 in. A 560 by 55 by 2-mm (22 by 2 1/4 by 1/16-in.) sheet metal shield is attached above the window, slanting downwards at an angle of 60° to shield the observation window. The steel or stainless steel panel holder is notched along the bottom or supporting lip of the angle at 25-mm (1-in.) intervals to assist in the measurements of the flame advance.

NOTE 1—A rule can also be mounted outside the observation window to help measure the flame advancement.

4.1.4 A hole is drilled in the side of the specimen holder immediately above the center of the burner to allow insertion of a thermocouple.

4.1.5 The tunnel shall be placed in an area as free from drafts as possible with facilities for removal or escape of combustion products. (Standard laboratory hood with forced draft off during test.)

<sup>5</sup> Quartz or high-silica glass has been found satisfactory for this purpose.

*Materials of Construction and Equipment List*

Item No	Item	Item No	Item
A	Base Plate	F	Glare Shield
B	Framework	G	Ceramic Insulator
C	Side and Front Panels	H	Spark Wire
D	Side Glass	I	Thermocouple
E	Burner		
Gas Control Valve and Gage not shown			

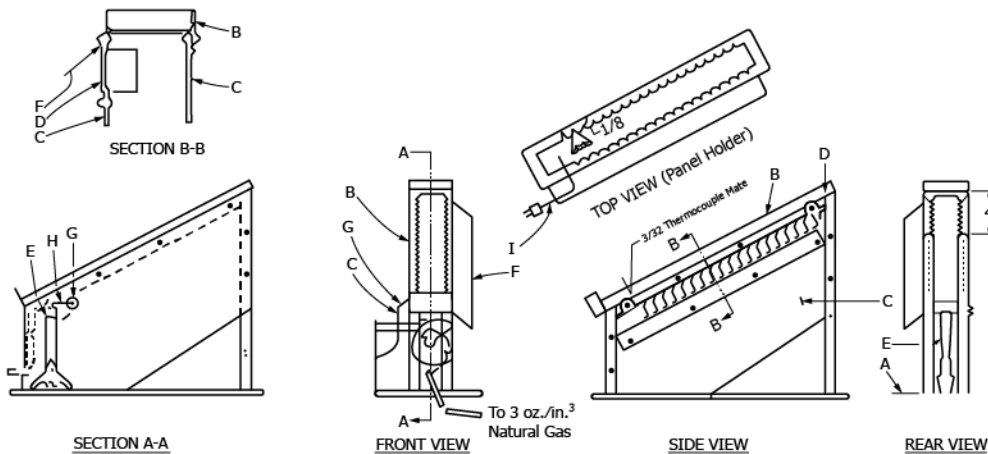

**FIG. 1 Flame Tunnel**