

INTERNATIONAL STANDARD

NORME INTERNATIONALE

Cable management systems – Cable ties for electrical installations

Systèmes de câblage – Colliers pour installations électriques

[IEC 62275:2022](https://standards.iteh.ai/catalog/standards/sist/db589f7f-196b-4af4-9c3a-ca689837f19d/iec-62275-2022)

<https://standards.iteh.ai/catalog/standards/sist/db589f7f-196b-4af4-9c3a-ca689837f19d/iec-62275-2022>



THIS PUBLICATION IS COPYRIGHT PROTECTED

Copyright © 2022 IEC, Geneva, Switzerland

All rights reserved. Unless otherwise specified, no part of this publication may be reproduced or utilized in any form or by any means, electronic or mechanical, including photocopying and microfilm, without permission in writing from either IEC or IEC's member National Committee in the country of the requester. If you have any questions about IEC copyright or have an enquiry about obtaining additional rights to this publication, please contact the address below or your local IEC member National Committee for further information.

Droits de reproduction réservés. Sauf indication contraire, aucune partie de cette publication ne peut être reproduite ni utilisée sous quelque forme que ce soit et par aucun procédé, électronique ou mécanique, y compris la photocopie et les microfilms, sans l'accord écrit de l'IEC ou du Comité national de l'IEC du pays du demandeur. Si vous avez des questions sur le copyright de l'IEC ou si vous désirez obtenir des droits supplémentaires sur cette publication, utilisez les coordonnées ci-après ou contactez le Comité national de l'IEC de votre pays de résidence.

IEC Secretariat
3, rue de Varembé
CH-1211 Geneva 20
Switzerland

Tel.: +41 22 919 02 11
info@iec.ch
www.iec.ch

About the IEC

The International Electrotechnical Commission (IEC) is the leading global organization that prepares and publishes International Standards for all electrical, electronic and related technologies.

About IEC publications

The technical content of IEC publications is kept under constant review by the IEC. Please make sure that you have the latest edition, a corrigendum or an amendment might have been published.

IEC publications search - webstore.iec.ch/advsearchform

The advanced search enables to find IEC publications by a variety of criteria (reference number, text, technical committee, ...). It also gives information on projects, replaced and withdrawn publications.

IEC Just Published - webstore.iec.ch/justpublished

Stay up to date on all new IEC publications. Just Published details all new publications released. Available online and once a month by email.

IEC Customer Service Centre - webstore.iec.ch/csc

If you wish to give us your feedback on this publication or need further assistance, please contact the Customer Service Centre: sales@iec.ch.

IEC Products & Services Portal - products.iec.ch

Discover our powerful search engine and read freely all the publications previews. With a subscription you will always have access to up to date content tailored to your needs.

Electropedia - www.electropedia.org

The world's leading online dictionary on electrotechnology, containing more than 22 300 terminological entries in English and French, with equivalent terms in 19 additional languages. Also known as the International Electrotechnical Vocabulary (IEV) online.

A propos de l'IEC

La Commission Electrotechnique Internationale (IEC) est la première organisation mondiale qui élabore et publie des Normes internationales pour tout ce qui a trait à l'électricité, à l'électronique et aux technologies apparentées.

A propos des publications IEC

Le contenu technique des publications IEC est constamment revu. Veuillez vous assurer que vous possédez l'édition la plus récente, un corrigendum ou amendement peut avoir été publié.

Recherche de publications IEC -

webstore.iec.ch/advsearchform

La recherche avancée permet de trouver des publications IEC en utilisant différents critères (numéro de référence, texte, comité d'études, ...). Elle donne aussi des informations sur les projets et les publications remplacées ou retirées.

IEC Just Published - webstore.iec.ch/justpublished

Restez informé sur les nouvelles publications IEC. Just Published détaille les nouvelles publications parues. Disponible en ligne et une fois par mois par email.

Service Clients - webstore.iec.ch/csc

Si vous désirez nous donner des commentaires sur cette publication ou si vous avez des questions contactez-nous: sales@iec.ch.

IEC Products & Services Portal - products.iec.ch

Découvrez notre puissant moteur de recherche et consultez gratuitement tous les aperçus des publications. Avec un abonnement, vous aurez toujours accès à un contenu à jour adapté à vos besoins.

Electropedia - www.electropedia.org

Le premier dictionnaire d'électrotechnologie en ligne au monde, avec plus de 22 300 articles terminologiques en anglais et en français, ainsi que les termes équivalents dans 19 langues additionnelles. Egalement appelé Vocabulaire Electrotechnique International (IEV) en ligne.

INTERNATIONAL STANDARD

NORME INTERNATIONALE

Cable management systems – Cable ties for electrical installations

Systèmes de câblage – Colliers pour installations électriques

[IEC 62275:2022](https://standards.iteh.ai/catalog/standards/sist/db589f7f-196b-4af4-9c3a-ca689837f19d/iec-62275-2022)

<https://standards.iteh.ai/catalog/standards/sist/db589f7f-196b-4af4-9c3a-ca689837f19d/iec-62275-2022>

INTERNATIONAL
ELECTROTECHNICAL
COMMISSION

COMMISSION
ELECTROTECHNIQUE
INTERNATIONALE

ICS 29.120.10; 29.120.99

ISBN 978-2-8322-6060-9

**Warning! Make sure that you obtained this publication from an authorized distributor.
Attention! Veuillez vous assurer que vous avez obtenu cette publication via un distributeur agréé.**

CONTENTS

FOREWORD	4
1 Scope	6
2 Normative references	6
3 Terms and definitions	6
4 General requirements	8
5 General notes on tests	8
6 Classification	13
6.1 According to material	13
6.1.1 Metallic component	13
6.1.2 Non-metallic component	13
6.1.3 Composite component	13
6.2 According to loop tensile strength for cable ties and mechanical strength for fixing devices	13
6.2.1 Loop tensile strength for cable ties	13
6.2.2 Type 1 – Retains at least 50 % of declared loop tensile strength for cable ties and mechanical strength for fixing devices after test conditions	13
6.2.3 Type 2 – Retains 100 % declared loop tensile strength for cable ties and mechanical strength for fixing devices after test conditions	13
6.2.4 According to loop tensile strength and mechanical strength of integral devices	14
6.3 According to temperature	14
6.3.1 According to maximum operating temperature for application given in Table 4	14
6.3.2 According to minimum operating temperature for application given in Table 5	14
6.3.3 According to minimum temperature during installation as declared by the manufacturer	14
6.4 According to contribution to fire for non-metallic and composite cable ties and integral devices only	14
6.4.1 Flame propagating	14
6.4.2 Non-flame propagating	14
6.5 According to environmental influences	15
6.5.1 According to resistance to ultraviolet light for non-metallic and composite components	15
6.5.2 According to resistance to corrosion for metallic and composite components	15
7 Marking and documentation	15
8 Construction	17
9 Mechanical properties	18
9.1 Requirements	18
9.2 Installation test	18
9.3 Minimum installation temperature test for cable ties	18
9.4 Minimum operating temperature test for cable ties	19
9.5 Loop tensile strength test for cable ties classified according to 6.2.2	21
9.5.1 As-received condition	21
9.5.2 After heat ageing	21
9.5.3 After temperature cycling	22

9.6	Loop tensile strength test for cable ties classified according to 6.2.3	22
9.6.1	As-received condition	22
9.6.2	After heat ageing	23
9.6.3	After temperature cycling	23
9.6.4	After vibration test for metallic cable ties	24
9.7	Mechanical strength test for fixing devices and integral devices	25
9.7.1	As-received condition	25
9.7.2	After heat ageing	31
9.7.3	After temperature cycling	32
10	Contribution to fire	33
11	Environmental influences	35
11.1	Resistance to ultraviolet light	35
11.2	Resistance to corrosion	38
12	Electromagnetic compatibility	38
Annex A (normative) Compliance checks to be carried out for cable ties and fixing devices currently complying with IEC 62275:2018 (Edition 3) in order to comply with IEC 62275:2022 (Edition 4) (i.e., this document)		39
Bibliography		40
Figure 1	– Reference thickness for cable ties	9
Figure 2	– Typical arrangements for cable tie orientation on split mandrel for tensile test	12
Figure 3	– Test piston for durability test for marking	16
Figure 4	– Test apparatus for cable tie impact test	21
Figure 5	– Typical arrangement for the vibration test	25
Figure 6	– Typical arrangement of test assembly for fixing devices and for integral devices	31
Figure 7	– Arrangement for the needle flame test	35
Figure 8	– Recommended sample repositioning for ultraviolet light and water exposure	37
Table 1	– Stabilization time for samples	9
Table 2	– Test mandrel diameter	10
Table 3	– Loop tensile strength	13
Table 4	– Maximum operating temperature for application	14
Table 5	– Minimum operating temperature for application	14
Table 6	– Literature information	17
Table 7	– Energy values of hammer	21
Table A.1	– Required compliance checks	39

INTERNATIONAL ELECTROTECHNICAL COMMISSION

**CABLE MANAGEMENT SYSTEMS –
CABLE TIES FOR ELECTRICAL INSTALLATIONS**

FOREWORD

- 1) The International Electrotechnical Commission (IEC) is a worldwide organization for standardization comprising all national electrotechnical committees (IEC National Committees). The object of IEC is to promote international co-operation on all questions concerning standardization in the electrical and electronic fields. To this end and in addition to other activities, IEC publishes International Standards, Technical Specifications, Technical Reports, Publicly Available Specifications (PAS) and Guides (hereafter referred to as "IEC Publication(s)"). Their preparation is entrusted to technical committees; any IEC National Committee interested in the subject dealt with may participate in this preparatory work. International, governmental and non-governmental organizations liaising with the IEC also participate in this preparation. IEC collaborates closely with the International Organization for Standardization (ISO) in accordance with conditions determined by agreement between the two organizations.
- 2) The formal decisions or agreements of IEC on technical matters express, as nearly as possible, an international consensus of opinion on the relevant subjects since each technical committee has representation from all interested IEC National Committees.
- 3) IEC Publications have the form of recommendations for international use and are accepted by IEC National Committees in that sense. While all reasonable efforts are made to ensure that the technical content of IEC Publications is accurate, IEC cannot be held responsible for the way in which they are used or for any misinterpretation by any end user.
- 4) In order to promote international uniformity, IEC National Committees undertake to apply IEC Publications transparently to the maximum extent possible in their national and regional publications. Any divergence between any IEC Publication and the corresponding national or regional publication shall be clearly indicated in the latter.
- 5) IEC itself does not provide any attestation of conformity. Independent certification bodies provide conformity assessment services and, in some areas, access to IEC marks of conformity. IEC is not responsible for any services carried out by independent certification bodies.
- 6) All users should ensure that they have the latest edition of this publication.
- 7) No liability shall attach to IEC or its directors, employees, servants or agents including individual experts and members of its technical committees and IEC National Committees for any personal injury, property damage or other damage of any nature whatsoever, whether direct or indirect, or for costs (including legal fees) and expenses arising out of the publication, use of, or reliance upon, this IEC Publication or any other IEC Publications.
- 8) Attention is drawn to the Normative references cited in this publication. Use of the referenced publications is indispensable for the correct application of this publication.
- 9) Attention is drawn to the possibility that some of the elements of this IEC Publication may be the subject of patent rights. IEC shall not be held responsible for identifying any or all such patent rights.

IEC 62275 has been prepared by subcommittee 23A: Cable management systems, of IEC technical committee 23: Electrical accessories. It is an International Standard.

This fourth edition cancels and replaces the third edition published in 2018. This edition constitutes a technical revision.

This edition includes the following significant technical changes with respect to the previous edition:

- a) scope clarification,
- b) new definitions,
- c) deletion of the exception for the stabilization of the moisture content,
- d) possibility to carry out tensile strength tests with dead weights,
- e) differentiation of rubber and acrylic adhesive fixings,
- f) clarification for mechanical testing of integral devices,
- g) clarifications on Table 6,
- h) clarifications in 9.1,

- i) the minimum installation temperature test for cable ties is carried out only when the declared minimum temperature is lower than 0 °C,
- j) a requirement that metallic cable ties be classified according to 6.2.3,
- k) definition of colours to be tested for contribution to fire,
- l) addition of a "some countries" note in Clause 10,
- m) clarification of the mounting of fixing devices in the resistance to ultraviolet light test,
- n) clarification on the testing of integral devices in the resistance to ultraviolet light test.

The text of this International Standard is based on the following documents:

Draft	Report on voting
23A/1025/FDIS	23A/1029/RVD

Full information on the voting for its approval can be found in the report on voting indicated in the above table.

The language used for the development of this International Standard is English.

This document was drafted in accordance with ISO/IEC Directives, Part 2, and developed in accordance with ISO/IEC Directives, Part 1 and ISO/IEC Directives, IEC Supplement, available at www.iec.ch/members_experts/refdocs. The main document types developed by IEC are described in greater detail at www.iec.ch/publications.

The following differing practices of a less permanent nature exist in the countries indicated below.

- 6.2.2: Additional type classifications are applicable when pre-qualified moulding materials are used (Canada, USA).
- 6.2.3: Additional type classifications are applicable when pre-qualified moulding materials are used (Canada, USA).
- 7.3: Some marking information is required to be placed on the packaging (Canada, Russia, USA).

In this document, the following print types are used:

- Requirements proper: in roman type.
- *Test specifications: in italic type.*
- Notes: in smaller roman type.

The committee has decided that the contents of this document will remain unchanged until the stability date indicated on the IEC website under webstore.iec.ch in the data related to the specific document. At this date, the document will be

- reconfirmed,
- withdrawn,
- replaced by a revised edition, or
- amended.

CABLE MANAGEMENT SYSTEMS – CABLE TIES FOR ELECTRICAL INSTALLATIONS

1 Scope

This document specifies requirements for metallic, non-metallic and composite cable ties and their associated fixing devices as a means used for managing or securing the wiring systems in electrical installations. Cable ties and associated fixing devices can also be suitable for other applications, such as support of wiring systems, and where so used, additional requirements can apply.

This document does not contain requirements that evaluate any electrical insulation properties of the cable tie or mechanical protection of the cables provided by the cable tie. This document contains requirements for the mechanical interface of an adhesive fixing device to a solid surface. It does not consider the mechanical behaviour of the solid surface in itself.

This document does not consider the mechanical interface, for example the mounting screw, of a fixing device other than adhesive to a solid surface.

2 Normative references

The following documents are referred to in the text in such a way that some or all of their content constitutes requirements of this document. For dated references, only the edition cited applies. For undated references, the latest edition of the referenced document (including any amendments) applies.

IEC 60068-2-6:2007, *Environmental testing – Part 2-6: Tests – Test Fc: Vibration (sinusoidal)*

IEC 60216-4-1:2006, *Electrical insulating materials – Thermal endurance properties – Part 4-1: Ageing ovens – Single-chamber ovens*

IEC 60695-11-5:2016, *Fire hazard testing – Part 11-5: Test flames – Needle-flame test method – Apparatus, confirmatory test arrangement and guidance*

ISO 4892-2:2013, *Plastics – Methods of exposure to laboratory light sources – Part 2: Xenon-arc lamps*

ISO 4892-2:2013/AMD1:2021

ISO 9227:2017, *Corrosion tests in artificial atmospheres – Salt spray tests*

3 Terms and definitions

For the purposes of this document, the following terms and definitions apply.

ISO and IEC maintain terminological databases for use in standardization at the following addresses:

- IEC Electropedia: available at <http://www.electropedia.org/>
- ISO Online browsing platform: available at <http://www.iso.org/obp>

3.1 cable tie

band or length of material, employing a locking device, used for bundling or tying groups of cables together, securing and/or supporting the cables

Note 1 to entry: Type 1 and Type 2 cable ties are classified in 6.2.2 and 6.2.3.

Note 2 to entry: In some countries, such as Canada and the United States, additional Type classifications are applicable when prequalified moulding materials are used. See UL 62275/CSA C22.2 No. 62275.

3.2 fixing device

component (such as a block or bracket) specifically designed to secure the cable tie to a mounting surface

3.3 metallic component

component that consists of metal only

Note 1 to entry: A metallic cable tie having a thin non-metallic or organic coating, where the coating does not contribute to the determination of the loop tensile strength, is considered a metallic component. In case of doubt, "as-received condition" tests with and without coating can be carried out.

3.4 non-metallic component

component that consists of non-metallic material only

3.5 composite component

component comprising both metallic and non-metallic materials where both metallic and non-metallic materials contribute to the determination of the loop tensile strength

3.6 environmental influence

effect of environmental hazards such as corrosive substances or solar radiation, etc.

3.7 loop tensile strength

reference mechanical characteristic of a cable tie with its locking mechanism engaged

3.8 locking device

feature of a cable tie for fixing it in a closed position

3.9 low hygroscopic polymer

polymer having the characteristic of not enabling attraction or holding water greater than 1,0 % by weight of the material from the surrounding environment at 23 °C and 50 % relative humidity

Note 1 to entry: Examples of low hygroscopic polymers include polypropylene, acetal, ethylene tetrafluoroethylene, ethylene chlorotrifluoroethylene, nylon 12, polyetheretherketone.

3.10 equilibrium moisture content

state at which a polymer neither absorbs nor releases moisture when exposed to a surrounding environment of 23 °C and 50 % relative humidity

3.11 integral device

single component, as produced, incorporating a cable tie and a fixing device that are not separable

3.12**adhesive fixing device**

fixing device provided with an adhesive tape specifically designed to secure the cable tie to a mounting surface

3.13**type test**

conformity test made on one or more items representative of the production

[SOURCE: IEC 60050-151:2001, 151-16-16]

3.14**bundle**

collection of wires or cables gathered or tied together

4 General requirements

A cable tie and a fixing device shall withstand the stresses likely to occur during recommended installation practice and perform under the conditions of classifications in Clause 6 as declared by the manufacturer.

Compliance is checked by carrying out all the appropriate specified tests.

NOTE Annex A details the compliance checks to be carried out for cable ties and fixing devices currently complying with IEC 62275:2018 in order to comply with IEC 62275:2022, Edition 4 (i.e., this document).

5 General notes on tests

5.1 Tests according to this document are type tests. Unless otherwise specified, tests are carried out with the cable ties and their associated fixing devices, where available, installed as in normal use according to the manufacturer's instructions.

Unless otherwise specified, requirements and tests for fixing devices also apply to adhesive fixing devices.

NOTE For guidance in determining product types and sample sets, a family of cable ties or fixing devices having material, construction characteristics, and classifications according to Clause 6, in common, are considered of the same product type. Examples for consideration are identical generic material description, material colours, or variable lengths of a cable tie of otherwise similar construction. The sample sets selected for testing from each product type is representative of the extremes of the range (example: shortest and longest), and the minimum performance level obtained for either extreme is considered to be representative of the entire range. Consideration is given to minor construction variations that can be determined by inspection to have no effect on performance, when determining product types.

5.2 Unless otherwise specified, tests on non-metallic and composite components shall commence when the samples have been removed from their packaging and then stabilized at a temperature of (23 ± 5) °C and at a relative humidity of (50 ± 5) %, for a period as indicated in Table 1.

NOTE This stabilization intends to achieve equilibrium moisture content for all samples before and after further conditioning and testing.

Table 1 – Stabilization time for samples

Reference thickness (RT) of device mm	Stabilization time days
$RT \leq 1,2$	7 ± 1
$1,2 < RT \leq 1,4$	21_{-7}^0
$1,4 < RT$	35_{-7}^0
All thicknesses for low hygroscopic polymers	$2 \pm 1/3$

The reference thickness of a cable tie is measured at the midpoint of the strap. The reference thickness of a fixing device shall be the smallest cross-section in the area that interfaces with the cable tie or as declared by the manufacturer. See Figure 1.

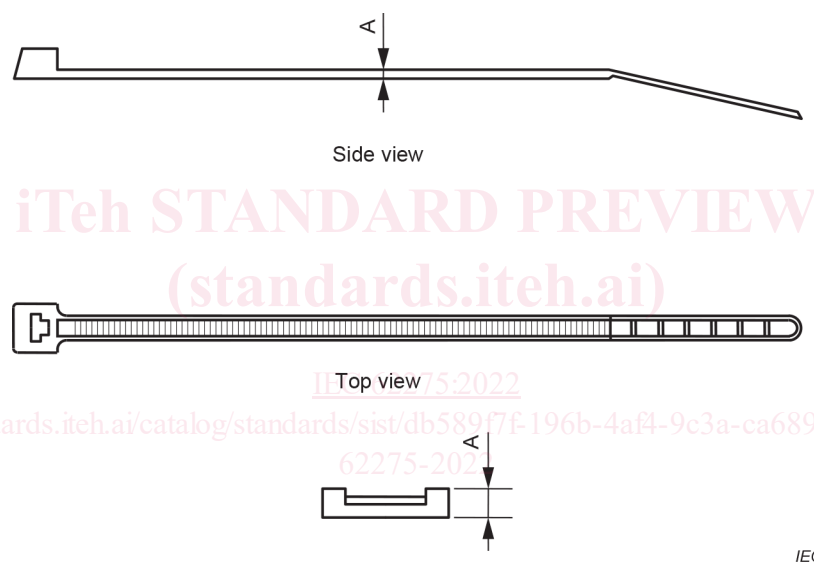
**Key**

A reference thickness of cable tie

Figure 1 – Reference thickness for cable ties

5.3 Unless otherwise specified, the tests shall be carried out at an ambient temperature of $(23 \pm 5) ^\circ\text{C}$ and with a relative humidity of between 40 % and 60 %.

5.4 Unless otherwise specified, three new samples are submitted to the tests and the requirements are satisfied if all the tests are met. If only one of the samples does not satisfy a test owing to an assembly or manufacturing fault, that test and any preceding one which may have influenced the results of the test shall be repeated. The tests that follow shall be carried out in the required sequence on another full set of samples, all of which shall comply with the requirements.

NOTE The applicant, when submitting the first set of samples, can also submit an additional set of samples which can be necessary if one sample fails. The test station will then without further request test the additional set of samples and will reject only if a further failure occurs. If the additional set of samples is not submitted at the same time, a failure of one sample will entail a rejection.

5.5 When toxic or hazardous processes are used, due regard shall be taken of the safety of persons within the test area.

5.6 Unless otherwise specified, the cross-head speed of a tensile machine used during the tests shall be $(25 \pm 2,5)$ mm/min. Dead weights can be used for conducting loop tensile strength tests for cable ties and integral devices classified according to 6.2.3, provided that no sudden application of force occurs.

5.7 Where required for heat ageing, a full draft circulating-air oven as specified in IEC 60216-4-1:2006 shall be used. A portion of the air shall be allowed to re-circulate and a substantial amount of air shall be admitted continuously to maintain the normal air content surrounding the samples. The oven shall be adjusted to achieve more than five complete fresh-air changes per hour.

5.8 An integral device shall be tested as a complete sample. The integral device shall be subjected to the conditionings for the cable tie prior to conducting the mechanical strength test for the fixing device in accordance with 9.7.

A fixing device, the performance of which is dependent on the mounting hole size, the thickness of the material sheet to which it is to be mounted, or the mounting orientation declared by the manufacturer in accordance with Table 6, shall comply with all applicable tests when the device is assembled to the minimum and maximum thickness of each mounting surface, in the largest hole size, and in each intended mounting orientation declared by the manufacturer. When it can be determined that a particular mounting orientation represents the most onerous condition, the results of the tests in that orientation may represent all mounting orientations.

An adhesive fixing device, the performance of which is dependent on the mounting surface or the mounting orientation, shall comply with all applicable tests when the device is assembled on the surfaces for which it is intended, and in each intended mounting orientation declared by the manufacturer. When it can be determined that a particular mounting orientation represents the most onerous condition, the results of the tests in that orientation may represent all mounting orientations.

IEC 62275:2022

5.9 Unless otherwise specified, when conducting the tests on cable ties in Clause 9, the samples shall be installed according to the manufacturer's instructions on a steel or aluminium mandrel which has a diameter A according to Table 2.

If the minimum declared diameter of the cable tie is greater than the diameter of the test mandrel specified in Table 2, then a test mandrel that has the minimum diameter as declared by the manufacturer shall be used.

The width B of the mandrel shall be at least 5 mm greater than the maximum width of the cable tie as shown in Figure 2.

Table 2 – Test mandrel diameter

Maximum declared diameter mm	Test mandrel diameter (A) mm
≤ 20	9,5 ± 1
> 20 and ≤ 38	20 ± 2
> 38	38 ± 2

For the loop tensile strength tests, the mandrel shall be split in two equal parts.

A metallic cable tie having a parallel entry strap shall be mounted to the mandrel as shown in Figure 2 a). Non-metallic or composite cable ties having a parallel entry strap shall be mounted to the mandrel as shown in Figure 2 b).

The excess end (tail) of the cable tie is permitted to be cut off after assembly, except in the tests where marking is required for the purpose of measurement (see 9.6).

The use of separate steel or aluminium conditioning mandrels is permitted. The conditioning mandrels need not be split but shall have a diameter approximately equivalent to the appropriate test mandrel to allow transfer of the sample to the test mandrel. Conditioned samples shall be carefully transferred to the appropriate test mandrel for carrying out the loop tensile test. Where it has been determined that the transfer of the samples from the conditioning mandrel to a test mandrel has influenced the test results, an additional sample set shall be conditioned and tested.

For integral devices, when it is determined impractical to condition the samples mounted to a rigid support, samples shall be conditioned separately. When conditioning separately, they shall be installed on a solid mandrel of similar size to the test fixture and the entire sample set may be installed on the same mandrel. After conditioning, each sample shall be mounted to the rigid support test fixture prior to the appropriate tensile pull. Where it has been determined that the transfer of the samples from the conditioning mandrel to a test mandrel has influenced the test results, an additional sample set shall be conditioned and tested.

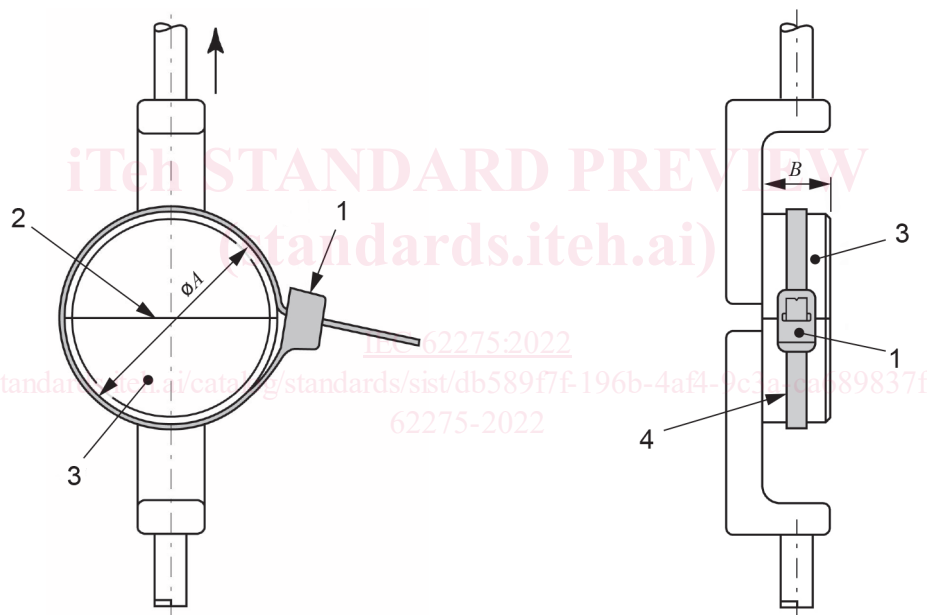

IEC

Key

- 1 locking device (head)
- 2 split line
- 3 mandrel
- 4 cable tie
- A* diameter of test mandrel
- B* width of test mandrel

Mandrels shall be made of steel or aluminium and shall be smooth and free of burrs.

Care should be taken that the separation of the two halves of the mandrel remains parallel to the split line.

Figure 2 a) – Typical arrangement for a right-angle non-metallic and composite cable tie and a parallel entry metallic cable tie orientation on split mandrel for tensile test

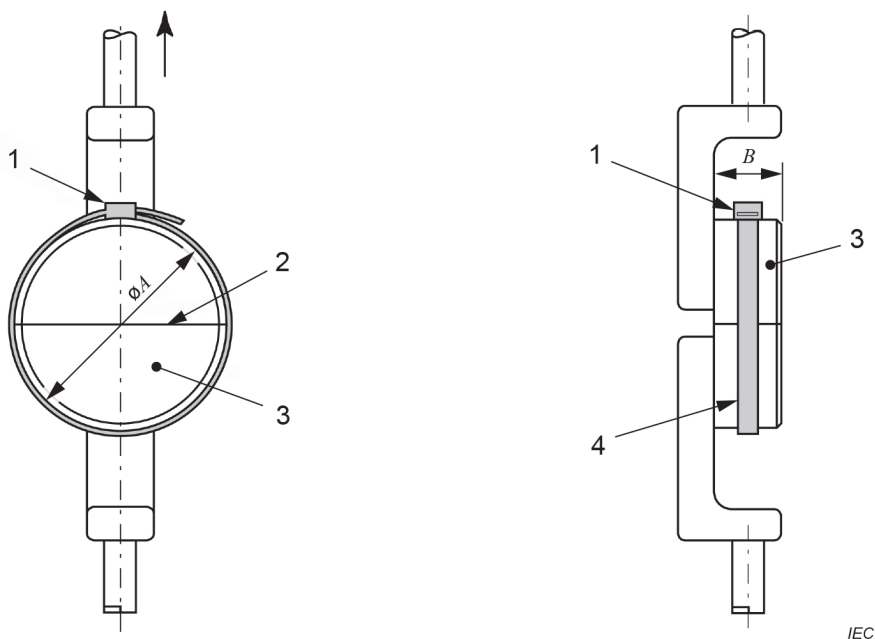

Key

- 1 locking device (head)
- 2 split line
- 3 mandrel
- 4 cable tie
- A* diameter of test mandrel
- B* width of test mandrel

Mandrels shall be made of steel or aluminium and shall be smooth and free of burrs.

Care should be taken that the separation of the two halves of the mandrel remains parallel to the split line.

Figure 2 b) – Typical arrangement for non-metallic and composite cable tie orientation on split mandrel for tensile test – Parallel entry strap

Figure 2 – Typical arrangements for cable tie orientation on split mandrel for tensile test

5.10 Tests for rubber adhesive fixing devices and integral devices on stainless steel or aluminium bare panel cover installation on the following surfaces:

- any bare metal surface,
- enamel painted metal surface,
- epoxy painted metal surface,
- polyester painted metal surface.

The installation on other surfaces and other painted surfaces shall be tested.

5.11 Tests for acrylic adhesive fixing devices and integral devices on stainless steel or aluminium bare panel cover the installation on any bare metal surface. The installation on other surfaces shall be tested.

5.12 Any other generic type of adhesive used on a fixing device or an integral device shall be tested on each surface.

5.13 Unless specified otherwise by the manufacturer, the samples are to be held to the panel for a period of 5_0^{+1} s with a force of (50 ± 5) N prior to the start of the prescribed pre-conditioning period or other exposures. Before applying any force, the preconditioning period recommended by the manufacturer shall be respected.

NOTE In Canada and the United States, an adhesive previously evaluated to the appropriate requirements for polymeric adhesive systems according to UL 746C or CAN/CSA-C22.2 No. 0.17 only requires the evaluation according to 9.7 on one substrate.

6 Classification

6.1 According to material

6.1.1 Metallic component

6.1.2 Non-metallic component

6.1.3 Composite component

6.2 According to loop tensile strength for cable ties and mechanical strength for fixing devices

6.2.1 Loop tensile strength for cable ties

As given in Table 3.

Table 3 – Loop tensile strength

Loop tensile strength	
N	
50	530
80	800
130	890
180	1 150
220	1 300
360	2 200
450	

Other values may be declared at the manufacturer's discretion.

NOTE Loop tensile strength does not provide an indication of long-term static load-bearing capabilities.

6.2.2 Type 1 – Retains at least 50 % of declared loop tensile strength for cable ties and mechanical strength for fixing devices after test conditions

NOTE In some countries, such as Canada and the United States, additional type classifications are applicable when pre-qualified moulding materials are used. See UL 62275/CSA C22.2 No.62275.

6.2.3 Type 2 – Retains 100 % declared loop tensile strength for cable ties and mechanical strength for fixing devices after test conditions

Metallic cable ties and fixing devices shall be classified according to 6.2.3.

NOTE In some countries, such as Canada and the United States, additional type classifications are applicable when pre-qualified moulding materials are used. See UL 62275/CSA C22.2 No.62275.