



Designation: **D953—18 D953 – 19**

Standard Test Method for Pin-Bearing Strength of Plastics¹

This standard is issued under the fixed designation D953; the number immediately following the designation indicates the year of original adoption or, in the case of revision, the year of last revision. A number in parentheses indicates the year of last reappraisal. A superscript epsilon (ϵ) indicates an editorial change since the last revision or reappraisal.

This standard has been approved for use by agencies of the U.S. Department of Defense.

1. Scope*

1.1 This test method covers the determination of the pin-bearing strength of rigid plastics in either sheet form, molded form, or in reinforced thermoset form. Procedures A and B are applicable for thermoplastic materials in tension loading and compression loading respectively. Procedure C is applicable for thermoset reinforced plastics. See the significance and use section (Section 5) for cautions in using this test standard.

1.2 Test data obtained by this test method is relevant and appropriate for use in quality control and engineering design.

1.3 The values stated in SI units are to be regarded as the standard. The values given in parentheses are for information only.

1.4 *This standard does not purport to address all of the safety concerns, if any, associated with its use. It is the responsibility of the user of this standard to establish appropriate safety, health, and environmental practices and determine the applicability of regulatory limitations prior to use.*

NOTE 1—This standard and ISO 12815 address the same subject matter, but differ in technical content.

1.5 *This international standard was developed in accordance with internationally recognized principles on standardization established in the Decision on Principles for the Development of International Standards, Guides and Recommendations issued by the World Trade Organization Technical Barriers to Trade (TBT) Committee.*

2. Referenced Documents

2.1 *ASTM Standards:*²

[D618 Practice for Conditioning Plastics for Testing](#)

[D883 Terminology Relating to Plastics](#)

[D5947 Test Methods for Physical Dimensions of Solid Plastics Specimens](#)

[D7290 Practice for Evaluating Material Property Characteristic Values for Polymeric Composites for Civil Engineering Structural Applications](#)

[E4 Practices for Force Verification of Testing Machines](#)

[E177 Practice for Use of the Terms Precision and Bias in ASTM Test Methods](#)

[E6 Terminology Relating to Methods of Mechanical Testing](#)

[E691 Practice for Conducting an Interlaboratory Study to Determine the Precision of a Test Method](#)

2.2 *ISO Standards:*

[ISO 12815 Fibre-reinforced plastic composites—Determination of plain-pin bearing strength](#)³

3. Terminology

3.1 *Definitions*—For definitions of technical terms used in this test method and associated with plastics issues refer to terminology contained in ASTM [D883](#).

3.2 *Definitions of Terms Specific to This Standard:*⁴

¹ This test method is under the jurisdiction of ASTM Committee [D20](#) on Plastics and is the direct responsibility of Subcommittee [D20.18](#) on Reinforced Thermosetting Plastics.

Current edition approved Nov. 1, 2018/Nov. 1, 2019. Published November 2018/December 2019. Originally approved in 1948. Last previous edition approved in 2010/2018 as [D953—10-D953 - 18](#). DOI: [10.1520/D0953-18.10.1520/D0953-19](#).

² For referenced ASTM standards, visit the ASTM website, [www.astm.org](#), or contact ASTM Customer Service at [service@astm.org](#). For *Annual Book of ASTM Standards* volume information, refer to the standard's Document Summary page on the ASTM website.

³ Available from American National Standards Institute (ANSI), 25 W. 43rd St., 4th Floor, New York, NY 10036, [http://www.ansi.org](#).

⁴ Attention is also directed to Terminology [E6](#).

*A Summary of Changes section appears at the end of this standard

3.2.1 *pin-bearing area*—the diameter of the hole multiplied by the thickness of the specimen.

3.2.2 *pin-bearing strength*—the pin-bearing stress at which the pin-bearing hole is deformed 4 % of its diameter for thermoplastics. For thermosets, the pin-bearing strength is the maximum pin-bearing stress at which the sample fails.

3.2.3 *pin-bearing stress*—the applied load in newtons (or pounds-force) divided by the pin-bearing area in mm² (or in²).

3.2.4 *edge distance ratio*—the distance from the center of the pin-bearing hole to the edge of the specimen in the direction of loading, divided by the diameter of the hole.

3.2.5 *maximum pin-bearing stress*—the maximum load in newtons (or pounds-force) sustained by the specimen, divided by the bearing area.

4. Summary of Test Method

4.1 This test standard is intended to test the pin-bearing strength of thermoplastic material using procedures A, B and reinforced thermoset plastics using procedure C. In procedures A and B, the sample with a pin-bearing hole will be tested in tension and compression respectively. While using procedure A and B, the load at which the hole deformation reaches 4 % of hole diameter, that load shall be considered as maximum pin-bearing load to calculate the pin-bearing strength. In procedure C, the sample shall be tested in compression and the maximum failure load of the sample shall be used as maximum pin-bearing load to calculate the pin-bearing strength. As reinforced thermoset plastics are much stiffer than thermoplastics, the pin-bearing failure happens much before the hole deformation reaches 4 % of the hole diameter. Using procedure C, it is allowed to test reinforced thermoset samples with over-sized holes for any engineering design purposes. Using the maximum pin-bearing load obtained by using an appropriate procedure, the pin-bearing strength of the material will be determined.

5. Significance and Use

5.1 This pin-bearing strength test for plastics is intended to apply in the specification of various thermoplastic or thermosetting products in sheet form where rivets, bolts, or similar fastenings are to be used in joining members or sections. It also is intended to apply wherever sheet materials of the classes indicated are required to sustain edgewise loads that are applied by means of pins or rods of circular cross section which pierce the sheet perpendicular to the surface.

5.2 The purpose of the test using procedures A and B is to determine the pin-bearing strength of thermoplastic material and to plot the pin-bearing stress versus the deformation of the hole. The allowable deformation of the hole in the material shall be such as to produce no looseness of joints.

5.3 The purpose of procedure C is to determine the ultimate pin-bearing strength of reinforced thermoset material. This test procedure enables the user to test the part in any direction that is intended to carry the pin-bearing loads. The sample size used in this procedure will cover thermoset reinforced plastics that are commonly used in infrastructure applications.

5.4 While it is a known fact that higher strength materials will generally give higher bearing strengths, there is no satisfactory method to estimate pin-bearing strength from tensile or compressive properties of the material.

5.5 Before proceeding with this test method, reference shall be made to the specification of the material being tested. Any test specimen preparation, conditioning, dimensions or testing parameters or combination thereof covered in the relevant ASTM materials specification shall take precedence over those in this test method. If there are no relevant ASTM material specifications then the default conditions apply.

6. Apparatus

6.1 *Testing Machine*—A properly calibrated universal testing machine that is capable to be operated at a speed of 1.3 ± 0.3 mm (0.05 \pm 0.01 in.)/min, except that in cases of certain types of materials where it is necessary to operate at a slower speed. The percentage of error of the testing machine shall be no more than ± 1 % of the applied load as determined in accordance with Practices E4.

6.2 *Tension Loading Fixture for Procedure A*—A three-plate fixture of hardened steel similar to that shown in Fig. 1.

6.3 *Extension Indicator*—A suitable instrument reading in 0.0025 mm (0.0001 in.) for indicating the movement of the free end of the specimen with relation to the bearing pin in the tension loading fixture. A dial gauge fitted with accessories for this purpose is shown in Fig. 2.

6.4 *Compression Loading Fixture for Procedure B*—A type of support with a suitable bearing pin similar to Fig. 3.

6.5 *Compression Indicator*—A suitable instrument reading to 0.0025 mm (0.0001 in.) for indicating the movement of the free end of the specimen with relation to the bearing pin in the compression loading fixture. A schematic of the dial gauge assembly for this purpose is shown in Fig. 4.

6.6 *Compression Loading Fixture for Procedure C*—The fixture as shown in Fig. 5 (A) is made up of two properly aligned steel angle uprights welded to a steel base plate. The welding of the angle uprights has to be on the outside only and not for the surfaces against which the specimen makes contact with so the sample can be supported flush to the surface of the angle and align without

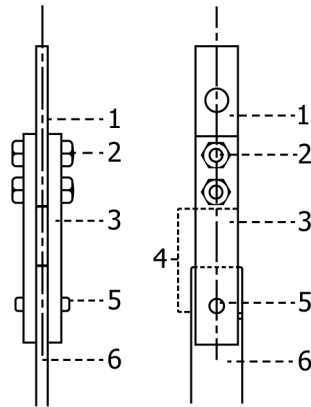

- 1—Hardened spacer plate.
- 2—6.3-mm (-in.) steel bolts in reamed holes.
- 3—Hardened side plate.
- 4—Extensometer span.
- 5—Hardened steel pin in reamed hole.
- 6—Test specimen.

NOTE 1—Critical dimensions are as follows:

Type	Bearing Hole Diameter, mm (in.)		Bearing Pin Diameter, mm (in.)		Thickness of Spacer Plate, mm ^A (in.)
I	3.175	+ 0.025 - 0.000	3.150	+ 0.000 - 0.025	3.2
	(0.125	+ 0.0010 - 0.0000)	(0.124	+ 0.0000 - 0.0010)	(¹ / ₈)
II	6.350	+ 0.025 - 0.000	6.325	+ 0.000 - 0.025	6.3
	(0.250	+ 0.0010 - 0.0000)	(0.249	+ 0.0000 - 0.0010)	(¹ / ₄)

^A The spacer plate shall be shimmed to a thickness of 0.025 to 0.125 mm (0.001 to 0.005 in.) greater than the specimen under test.

FIG. 1 Steel Tension Loading Fixture

any angularity. This fixture will support and align the sample normal to the loading ram. It is allowed to use C-clamps to provide lateral support to the sample against the fixture as shown in Fig. 5 (B). For quality assurance purposes, the nominal bearing pin diameter shall be the same as the thickness of the sample.

7. Test Specimens

7.1 The test specimens for Procedures A and B shall conform to the dimensions shown in Fig. 6. A size of test specimen shall be chosen that most nearly conforms to production requirements of the material and the type of loading under consideration. It is permitted to machine the specimen from sheet or molded to finished size. The bearing hole shall be located as shown in Fig. 6. It shall be drilled undersized and reamed to size as indicated. The hole shall be clean and smooth with sharp edges but not polished. The reaming operation shall be done in the drill press by hand without the use of a jig.

NOTE 2—The thicker specimens with the larger pin-bearing hole are likely to give the more precise results, although it is advantageous to use the thinner specimens with the smaller pin-bearing hole in testing certain relatively brittle plastics because they are less likely to fail prematurely.

7.2 The test specimens for procedure C shall conform to the dimensions shown in Fig. 7. The test specimen shall be a 76.2 mm by 76.2 mm (3 in. by 3 in.) sample machined from a part that mostly nearly conforms to the production requirements of the material under consideration. The specimen shall be clearly marked to identify the orientation of the material. The pin-bearing hole shall be located at a distance of 15.88 mm (0.625 in.) from the one edge of the sample in the direction of the loading. The hole shall be drilled undersized and reamed to size as indicated in Fig. 7. The hole shall be clean and smooth with sharp edges but not polished. The reaming operation shall be done in the drill press by hand without the use of a jig. The sample with pin-bearing hole shall be carefully machined at the mid-section of the hole to present half of the hole as shown in Fig. 7.

7.3 The dimensions given in Fig. 7 applies to holes up to 25.4 mm (1 in.). For pin-bearing holes bigger than 25.4 mm (1 in.) an edge distance (B) of 3 times the diameter of the pin-bearing pin shall be considered.

7.4 *Oversized Holes for Engineering Designs*—To determine the pin-bearing strength of oversized holes for engineering design purpose, it is allowed to use the compression fixture and the compression sample, prepared as described in 7.2 except that it is not

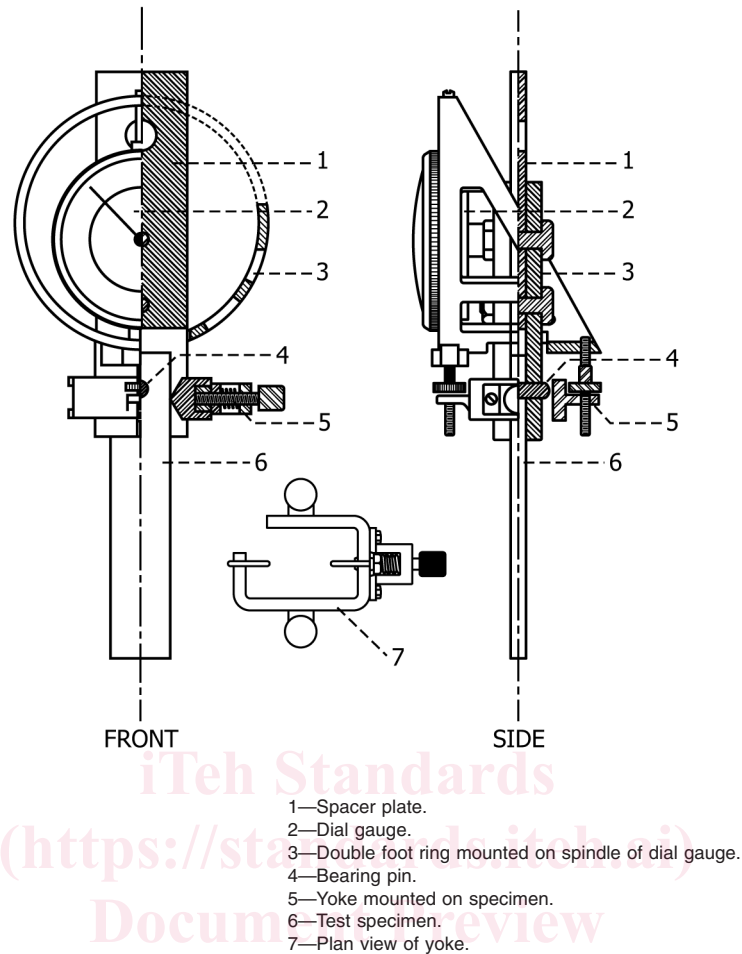

FIG. 2 Tension Loading Assembly

ASTM D953-19

<https://standards.iteh.ai/catalog/standards/sist/2e7333cf-8ece-411f-ab35-70792868467e/astm-d953-19>

required to clean or ream the hole. While determining the pin-bearing stress of an oversized hole, note that the values obtained for a particular combination of hole size, pin size, thickness, and material is acceptable only for that combination.

8. Number of Test Specimens

8.1 At least five specimens shall be tested for each sample in the case of isotropic materials.

8.2 Ten specimens, five perpendicular to and five parallel with the principal axis of anisotropy, shall be tested for each sample in case of anisotropic materials.

NOTE 3—If the intent of the testing is to obtain the characteristic value in accordance with Practice D7290, the sample numbers have to be a minimum of ten samples per direction of principal axis.

8.3 Specimens that break at some obvious flaw that is not naturally formed by the material processing method shall be discarded and retests made, unless such flaws constitute a variable the effect of which is being studied.

9. Conditioning

9.1 *Conditioning*—Condition the test specimens in accordance with Procedure A of Practice D618, unless otherwise specified by contract or the relevant ASTM material specification. Conditioning time is specified as a minimum. Temperature and humidity tolerances shall be in accordance with Section 7 of Practice D618 unless specified differently by contract or material specification.

9.2 *Test Conditions*—Conduct tests at the same temperature and humidity used for conditioning with tolerances in accordance with Section 7 of Practice D618 unless otherwise specified by contract or the relevant ASTM material specification.

10. Measurement of Dimensions

10.1 Measure the width and thickness of the conditioned test specimen to the nearest 0.025 mm (0.001 in.) at the bearing hole. Also, measure the pin diameter, diameter of the pin-bearing hole and the distance from the center of the pin-bearing hole to the

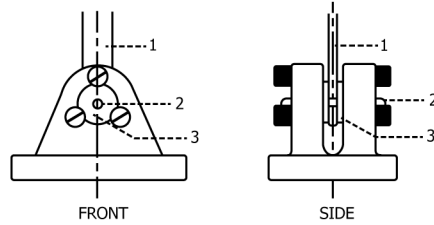

- 1—Test specimen.
- 2—Hardened steel pin.
- 3—Hardened thrust bushing.

NOTE 1—Critical dimensions are as follows:

Type	Bearing Hole Diameter, mm (in.)		Bearing Pin Diameter, mm (in.)		Minimum Clearance Between Bushings, mm (in.)
I	3.175	+ 0.025 – 0.000	3.150	+ 0.000 – 0.025	2.8
	(0.125	+ 0.0010 – 0.0000)	(0.124	+ 0.0000 – 0.0010)	(7/64)
II	6.350	+ 0.025 – 0.000	6.325	+ 0.000 – 0.025	6.0
	(0.250	+ 0.0010 – 0.0000)	(0.249	+ 0.0000 – 0.0010)	(15/64)

FIG. 3 Steel Compression Loading Fixture

edge of the specimen in the direction of the principal stress to the nearest 0.025 mm (0.001 in.). All measurements to be made using the applicable test methods in accordance with Test Method D5947.

11. Speed of Testing

11.1 The mean rate of crosshead travel in the testing of specimens shall not exceed 1.3 ± 0.3 mm (0.05 ± 0.01 in.)/min. In any case the crosshead movement shall be slow enough so that deflection gauge readings can be made accurately.

12. Procedure

12.1 The choice of either Procedure A for tension loading (12.2) or Procedure B for compression loading (12.3) is optional, but note that Procedure B gives higher pin-bearing strength values than Procedure A on the same material. Test specimens according to both Procedures A and B if a complete specification of pin-bearing strength is required.

12.2 *Procedure A for Tension Loading*—Mount the specimen to be tested in the tension loading fixture and attach a deformation indicator. If a dial gauge (Fig. 2) is used, adjust the yoke so that contact is made with the specimen at the level indicated in Fig. 1. Exception is taken in the case of those thermoplastic materials which exhibit extended plastic flow. Such specimens tend to “neck down” in the region of the pin-bearing hole, and it is necessary to mount the yoke 12.7 mm (½ in.) below the normal position indicated in A, Fig. 1, so that it will not slip during test.

12.3 *Procedure B for Compression Loading*—Mount the specimen to be tested in the compression loading fixture and load through a flat, hardened compression plate. Adjust the clearance between the thrust bushings of the loading fixture such that their contact with the specimen is sufficient to support it in a vertical position without binding. Clamp the hardwood cheek blocks in place and attach the deformation indicator (see Fig. 4).

12.4 *Details Common to Procedures A and B*—Take care in aligning the long axis of the specimen with the center line of the testing fixture. Load the specimen at the prescribed rate of crosshead travel and take deformation readings. In case autographic recording is not available, record the load sustained by the specimen for every 0.0127-mm (0.0005-in.) deformation up to a total deformation of 4 % of the pin-bearing hole diameter. Continue the test until maximum load is sustained and the corresponding deformation of the pin-bearing hole is recorded.

12.5 *Procedure C for Compression Loading*—Mount the specimen to be tested in the steel compression fixture against the steel angle uprights as shown in Fig. 5. Clamp the sample to the fixture to keep it in place during the testing. Place the bearing pin in the half-circle of the specimen and center this assembly under the flat platen attachment of the test machine. Load the specimen at the prescribed rate of crosshead travel until the maximum load is recorded. Record load vs. position readings throughout the test.

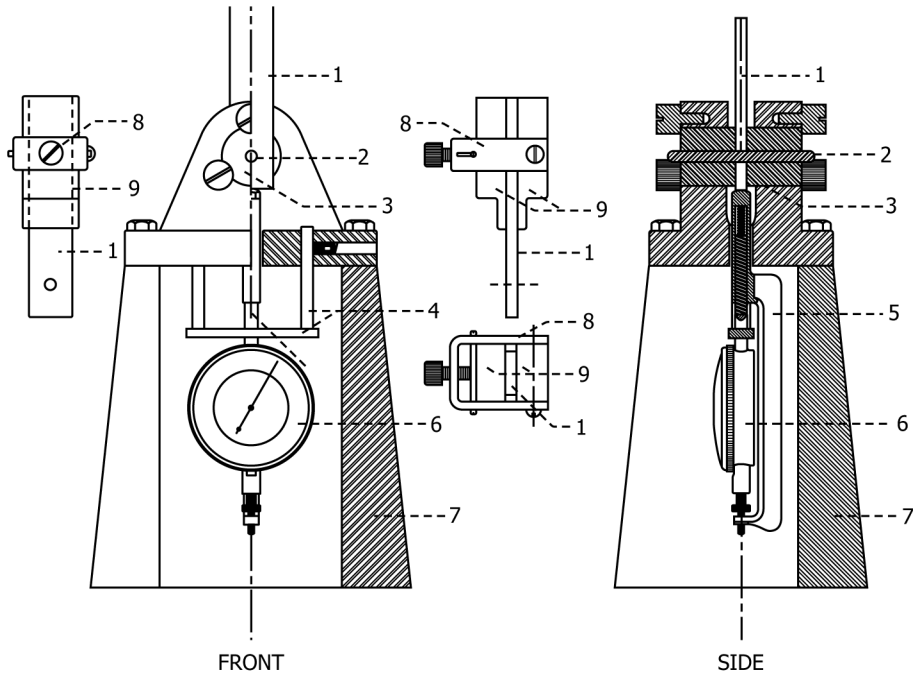

- 1—Test specimen.
- 2—Bearing pin.
- 3—Thrust bushings.
- 4—Hanger for dial gauge.
- 5—Spring-supported thrust member of transfer deformation of specimen to dial gauge foot.
- 6—Dial gauge.
- 7—Pedestal support.
- 8—Clamp for cheek blocks.
- 9—Hard maple cheek blocks to stabilize test specimen.

FIG. 4 Compression Loading Assembly

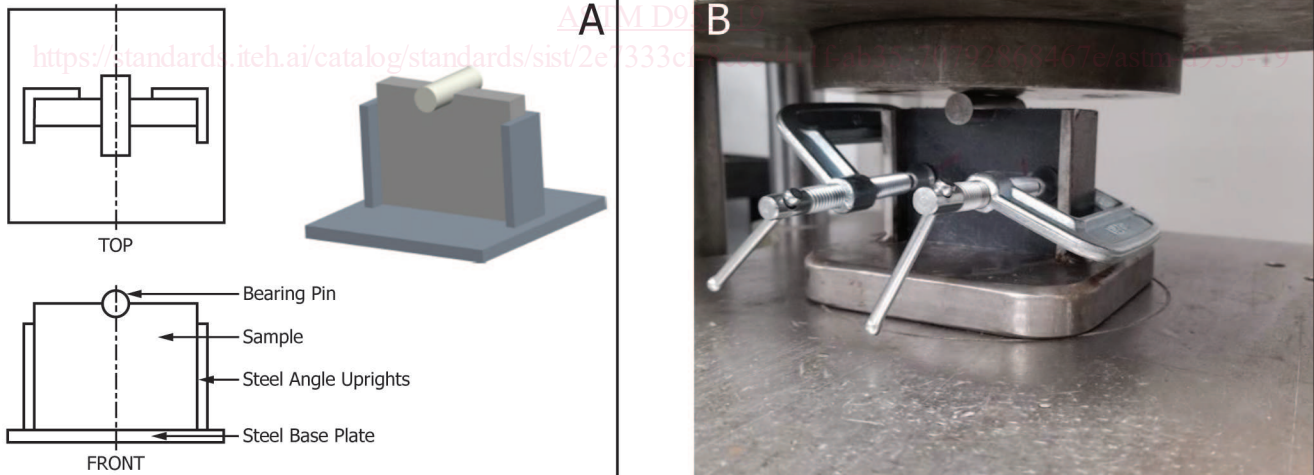

FIG. 5 Compression Loading Fixture for Procedure C (With Picture of Sample Under Pin-Bearing Load)

13. Calculation

13.1 Plot the load - deflection curve for each specimen.

13.2 For Procedures A and B, use a template as described in the Appendix to determine the load at 4 % hole deformation. For Procedure C, use the ultimate (maximum) load for pin-bearing strength calculations.

13.3 Calculate the pin-bearing strength as follows:

$$S_b = P/(td) \tag{1}$$