



Designation: ~~D6598 – 11~~ D6598 – 19

## Standard Guide for Installing and Operating Settlement Platforms<sup>Points</sup> for Monitoring Vertical Deformations<sup>1</sup>

This standard is issued under the fixed designation D6598; the number immediately following the designation indicates the year of original adoption or, in the case of revision, the year of last revision. A number in parentheses indicates the year of last reapproval. A superscript epsilon ( $\epsilon$ ) indicates an editorial change since the last revision or reapproval.

### 1. Scope\*

1.1 This guide provides recommended designs and procedures for the fabrication, installation, operation, and reading of settlement platformpoint(s) to determine the magnitude and rate of foundation, fill settlements, or both generally under a fill or embankment load. Two types of settlement platformspoints are described – those being monitored by elevation surveys from an external bench mark and those that include an internal reference system supported on unyielding soil or rock beneath the compressible layer(s) of interest.

1.2 *Units*—The values stated in SI units are to be regarded as standard. No other units of measurement are included in this standard.

*1.3 This guide offers an organized collection of information or a series of options and does not recommend a specific course of action. This document cannot replace education or experience and should be used in conjunction with professional judgement. Not all aspects of this guide may be applicable in all circumstances. This ASTM standard is not intended to represent or replace the standard of care by which the adequacy of a given professional service must be judged, nor should this document be applied without consideration of a project's many unique aspects. The word "standard" in the title of this document means only that the document has been approved through the ASTM consensus process.*

1.4 *This guide does not purport to address all of the safety concerns, if any, associated with its use. It is the responsibility of the user of this guide to establish appropriate safety, health, and environmental practices and determine the applicability of regulatory limitations prior to use.*

~~1.4 This guide offers an organized collection of information or a series of options and does not recommend a specific course of action. This document cannot replace education or experience and should be used in conjunction with professional judgement. Not all aspects of this guide may be applicable in all circumstances. This ASTM standard is not intended to represent or replace the standard of care by which the adequacy of a given professional service must be judged, nor should this document be applied without consideration of a project's many unique aspects. The word "standard" in the title of this document means only that the document has been approved through the ASTM consensus process.~~

*1.5 This international standard was developed in accordance with internationally recognized principles on standardization established in the Decision on Principles for the Development of International Standards, Guides and Recommendations issued by the World Trade Organization Technical Barriers to Trade (TBT) Committee.*

### 2. Referenced Documents

#### 2.1 ASTM Standards:<sup>2</sup>

[D653 Terminology Relating to Soil, Rock, and Contained Fluids](#)

[D3740 Practice for Minimum Requirements for Agencies Engaged in Testing and/or Inspection of Soil and Rock as Used in Engineering Design and Construction](#)

[D5092 Practice for Design and Installation of Groundwater Monitoring Wells](#)

[D5782 Guide for Use of Direct Air-Rotary Drilling for Geoenvironmental Exploration and the Installation of Subsurface Water-Quality Monitoring Devices](#)

[D5872 Guide for Use of Casing Advancement Drilling Methods for Geoenvironmental Exploration and Installation of Subsurface Water Quality Monitoring Devices](#)

<sup>1</sup> This guide is under the jurisdiction of ASTM Committee D18 on Soil and Rock and is the direct responsibility of Subcommittee D18.23 on Field Instrumentation. Current edition approved Nov. 1, 2011; Nov. 1, 2019. Published January 2012; November 2019. Originally approved in 2000. Last previous edition approved in 2007 as D6598-07-11. DOI: 10.1520/D6598-11; 10.1520/D6598-19.

<sup>2</sup> For referenced ASTM standards, visit the ASTM website, www.astm.org, or contact ASTM Customer Service at service@astm.org. For *Annual Book of ASTM Standards* volume information, refer to the standard's Document Summary page on the ASTM website.

\*A Summary of Changes section appears at the end of this standard

[D5876 Guide for Use of Direct Rotary Wireline Casing Advancement Drilling Methods for Geoenvironmental Exploration and Installation of Subsurface Water-Quality Monitoring Devices](#)  
[D6914 Practice for Sonic Drilling for Site Characterization and the Installation of Subsurface Monitoring Devices](#)

### 3. Terminology

#### 3.1 Definitions:

3.1.1 For definitions of common technical terms in this standard, refer to Terminology **D653**.

#### 3.2 Definitions of Terms Specific to This Standard:

3.2.1 *anchor, n*—a device that holds the settlement point system in place and serves as a fixed reference point at the base of a settlement point system.

3.2.2 *settlement platform—extendible riser, n*—a system consisting of a square base platform with an extendible riser pipe of known length which is used to monitor vertical deformations at the elevation of the base platform by survey measurements made of the top of the riser pipe. metal shaft or pipe that can be incrementally lengthened using sections of the same material and appropriate couplings as fill is placed and compacted to ensure that the top of the riser remains above the level of the surrounding ground surface.

3.2.3 *external reference point system, n*—system for determining the amount of settlement by referencing the elevation of the settlement point to an outside elevation benchmark.

3.2.4 *external and internal reference point system—system, n*—with an external system, system for determining the amount of settlement is determined by referencing the elevation of the settlement platform to an outside elevation benchmark; with an internal system, the amount of settlement is determined by measuring the relative displacement of two co-axial riser pipes moving relative to each other, the outer riser pipe being attached to the base platform and the inner riser pipe being fixed to an unyielding stratum.

3.2.3 *anchor*—an anchor system that provides an internal fixed reference point below the base of the settlement platform system.

3.2.4 *extendible riser*—a metal shaft or pipe which can be incrementally lengthened using sections of the same material and appropriate couplings as fill is placed and compacted to ensure that the top of the riser remains above the level of the surrounding ground surface. Depending on whether an external or internal reference point is being used, there may be one or two risers.

3.2.5 *isolation casing—casing, n*—a casing of a larger diameter than the extendible riser is used in some installations to prevent down-drag of soil on the extendible riser that would otherwise be in contact with the soil from placing additional load on the platform and thereby leading to overestimates of deformations.

3.2.6 For definitions of other terms used in this guide see Terminology **D653**.

3.2.6 *settlement point, n*—a system consisting of an anchor at the depth of interest, at or below surface, with an extendible riser pipe of known length

<https://standards.iteh.ai/catalog/standards/sist/55438608-9caf-4d65-985f-2c4635156b1e/astm-d6598-19>

### 4. Summary of Standard Guide

4.1 The standard guide presents recommended designs for settlement platforms points along with procedures to install, operate and monitor them. The standard guide focuses on methods that permit (i) the effect of fill placement on underlying strata and (ii) the determination assessment of the relative deformation within a fill. The guide addresses ways in which the instrument is protected from downdrag effects from the fill soils as well as measures to protect the instrument from damage by earth moving equipment. Standard survey procedures are used to determine assess the magnitude of deformations. Recommended procedures for reporting the details of an installation and the recorded deformations are presented.

NOTE 1—These systems in practice are commonly referred to as settlement platforms because they have historically utilized base platforms. Recent developments in technology have expanded settlement observation systems to those which do not require base platforms in certain applications. This led to a modification in terminology to include the various systems.

### 5. Significance and Use

5.1 Earthen fills are often constructed as engineered structures, for example, dams, or to support engineered structures, for examples, roads or buildings. The weight of the fill may compress or deform the supporting soil or rock foundation resulting in settlement of the soil throughout and beneath the embankment. Temporary embankments or surcharge fills are constructed to increase the strength and/or reduce the compressibility of foundation soils prior to placement of the actual foundation or structure. The designers often monitor the settlement of the earth structure as a function of time to document the magnitude and rate of settlement, to evaluate the potential for future settlement, or to confirm the effectiveness of the surcharge and the schedule for its removal. The monitoring is performed using settlement platforms points installed prior to or during the embankment construction. A platform settlement point provides an accessible survey point that settles with a selected soil horizon within or below the embankment. Careful design and installation of the settlement platform point can isolate the survey point from extraneous sources of movement such as frost-induced heave, compression within the embankment, or volume changes caused by moisture gain or loss.

5.2 Various settlement platform point designs have been developed by the agencies and practitioners that use them. This standard guide provides designs and procedures that can be referred to in design guidelines, specifications and reports.

5.3 This standard guide is not meant to restrict the use of other equally appropriate designs and procedures for the fabrication, installation, operation, and reading of settlement platform points to monitor deformations in earthen deposits during and after construction.

NOTE 2—Notwithstanding the statements on precision and bias contained in this guide, the precision of this guide is dependent on the competence of the personnel performing it and the suitability of the equipment and facilities used. Agencies that meet the criteria of Practice D3740 are generally considered capable of competent and objective testing. Users of this guide are cautioned that compliance with Practice D3740 does not itself ensure reliable testing. Reliable testing depends on many factors; Practice D3740 provides a means of evaluating some of these factors.

## 6. Materials

6.1 A variety of materials are used in combination to provide a cost-effective, modular system. ~~Given that~~ Depending on the anticipated operational life of settlement platforms is typically relatively short, concerns about the settlement points, the long term durability are generally negligible. Accordingly of the components may have to be considered. Additionally, issues such as component weight, the ease with which the riser pipe can be extended and cost ~~need to dominate factor into~~ material selection decisions. The entire settlement platform point system consists of 4 or 5 distinct components depending on the specific design. Typical alternative configurations are shown in Figs. 1-34. Key distinctions between these different configurations are summarized in Table 1. Additional considerations regarding materials for each of these components are provided below.

**TABLE 1 Suitability and Use of Various Platform Settlement Point Configurations**

Configuration	Fill Deformations	Foundation Deformations	External Reference	Internal Reference
Fig. 1	No <sup>A</sup>	Yes	Yes	No
Fig. 2	No <sup>A</sup>	Yes	No <sup>B</sup>	Yes
Fig. 3	No <sup>A</sup>	Yes	Yes	No
Fig. 4	No <sup>A</sup>	Yes	No <sup>B</sup>	Yes
Fig. 5	No <sup>A</sup>	Yes	No <sup>B</sup>	Yes
Fig. 6	No <sup>A</sup>	Yes	No <sup>B</sup>	Yes

<sup>A</sup> Fill settlements could be determined with this configuration if base platform placed at higher elevation.

<sup>B</sup> External reference (control) could be used with these configurations also.

6.2 *Base Platform*—a square base platform typically ranging between 0.3 to 1.0 m ~~0.3 m to 1.0 m~~ on side is placed at the elevation for which the vertical deformation is required. In some cases, a steel platform 5 to 15 mm ~~5 mm to 15 mm~~ thick is used. Alternatively, a platform 25 to 50 mm ~~25 mm to 50 mm~~ thick fabricated from plywood is sometimes used. This may be particularly desirable in short term applications where degradation of the wood is not a concern. Other materials such as concrete can be used for the base platform. In all cases, the thickness of the base platform should be selected giving consideration to the area of the platform to ensure that its rigidity is sufficient to avoid local bending.

6.3 *Riser Pipe*—a rigid metal shaft or an assembly of a rigid metal shaft and a rigid metal pipe, typically 25 to 50 mm ~~25 mm to 50 mm~~ in diameter, is used to reflect the vertical deformation of the platform at the ground surface. As layers of fill are placed, the riser pipes are extended by adding additional sections of pipe. Threaded couplings are typically used. These have the advantage that after the survey program is complete, some, if not all the riser pipe can be recovered before the installation is grouted to seal off any unwanted access for water to the subsurface. Use of PVC or other lightweight pipe materials is not recommended for reasons of survivability.

6.4 *Riser Pipe Isolation Casing*—an external pipe is sometimes used to isolate the riser pipe from the surrounding soil. This is done to prevent the effects of extraneous sources of movement such as frost-induced heave, skin-friction due to compression within the fill itself, or moisture induced volume changes. Given that this casing is only to isolate the riser pipe from these surrounding effects and does not constitute part of the deformation measuring system, PVC or other lightweight pipe materials are typically recommended. As with the riser pipe, the isolation casing can be extended as layers of fill are added. Isolation casing is typically only required if the fill or embankment height is greater than about 6 m or the plate is to be seated on a thin stiff layer overlying softer material where a punching failure might occur as a result of the down-drag load applied to the riser-pipe. This pipe is required for borehole settlement point installations, such as illustrated in Fig. 2, as it is used to set the anchor. In these cases the isolation casing is composed of rigid metal components.

6.5 *Surface Protection Monument*—for settlement platforms that remain in place following completion of construction, installation of a surface protection monument to protect the riser pipe from tampering is advisable. Design of a protective casing system as described in Practice D5092 is recommended.

6.6 For installations where an internal reference or benchmark supported on unyielding soil or rock beneath the compressible layer(s) of interest is used, rigid metal pipe similar to that described in 6.3 above is recommended. Alternatively, an anchor is used in conjunction with metal pipe to ensure a fixed base firmly anchored reference point. A typical anchor may consist of a number of metal prongs, which are driven from an initially retracted position through slots in the conical drive point of an outer metal pipe using an inner metal riser pipe.

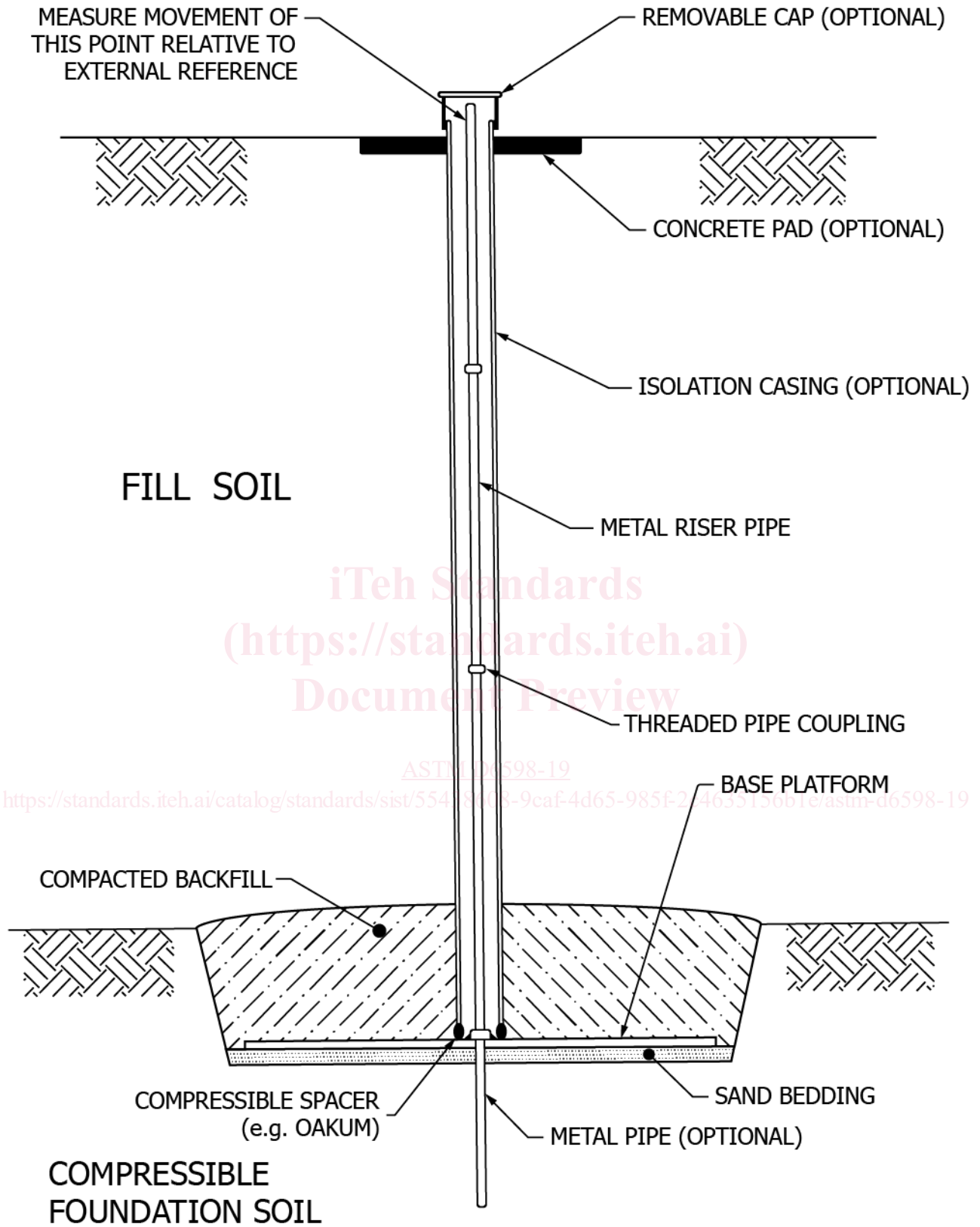

FIG. 1 Typical Installation for Externally Referenced Settlement Point with Base Platform

7. Procedure

7.1 A variety of instrument designs are possible depending on the specific application for which the settlement platform is to be used and whether an external or internal reference point or bench mark is to be used. This standard test method describes a