



Designation: D5182 – 19

Standard Test Method for Evaluating the Scuffing Load Capacity of Oils (FZG Visual Method)¹

This standard is issued under the fixed designation D5182; the number immediately following the designation indicates the year of original adoption or, in the case of revision, the year of last revision. A number in parentheses indicates the year of last reapproval. A superscript epsilon (ϵ) indicates an editorial change since the last revision or reapproval.

1. Scope*

1.1 This test method, the Forschungstelle für Zähräder und Getriebebau (Research Site for Gears and Transmissions) Visual Method, commonly referred to as the FZG Visual Method, is intended to measure the scuffing load capacity of oils used to lubricate hardened steel gears. Scoring, a form of abrasive wear, is also included as a failure criteria in this test method. It is primarily used to assess the resistance to scuffing of mild additive treated oils such as industrial gear oils, transmission fluids, and hydraulic fluids. High EP type oils, for example, those oils meeting the requirements of API GL-4 and GL-5, generally exceed the capacity of the test rig and, therefore, cannot be differentiated with this test method.

1.2 The values stated in SI units are to be regarded as standard. No other units of measurement are included in this standard.

1.3 *This standard does not purport to address all of the safety concerns, if any, associated with its use. It is the responsibility of the user of this standard to establish appropriate safety, health, and environmental practices and determine the applicability of regulatory limitations prior to use.* For specific safety information, see Section 7, Section 8, 9.2, 9.3.1, and Annex A1.

1.4 *This international standard was developed in accordance with internationally recognized principles on standardization established in the Decision on Principles for the Development of International Standards, Guides and Recommendations issued by the World Trade Organization Technical Barriers to Trade (TBT) Committee.*

¹ This test method is under the jurisdiction of ASTM Committee D02 on Petroleum Products, Liquid Fuels, and Lubricants and is the direct responsibility of Subcommittee D02.L0.11 on Tribological Properties of Industrial Fluids and Lubricates.

Current edition approved Dec. 1, 2019. Published December 2019. Originally approved in 1991. Last previous edition approved in 2014 as D5182 – 97 (2014). DOI: 10.1520/D5182-19.

2. Referenced Documents

2.1 *ASTM Standards:*²

D235 Specification for Mineral Spirits (Petroleum Spirits) (Hydrocarbon Dry Cleaning Solvent)

G40 Terminology Relating to Wear and Erosion

2.2 *DIN Standard:*³

DIN 51 354 Teil 1 FZG Zahnrad Verspannungs Prüfmaschine—Allgemeine Arbeitsgrundlagen

3. Terminology

3.1 *Definitions:*

3.1.1 See also Terminology G40.

3.1.2 *abrasive wear, n*—wear due to hard particles or hard protuberances forced against and moving along a solid surface.

3.1.3 *adhesive wear (scuffing), n*—wear due to localized bonding between contacting solid surfaces leading to material transfer between the two surfaces or loss from either surface.

3.1.4 *scoring, n*—a severe form of wear characterized by the formation of extensive grooves and scratches in the direction of sliding.

3.1.5 *scratches, n*—the result of mechanical removal or displacement, or both, of material from a surface by the action of abrasive particles or protuberances sliding across the surfaces.

3.2 *Definitions of Terms Specific to This Standard:*

3.2.1 *polishing, n*—a mild form of abrasive wear resulting in minor loss of material and typically characterized by a smooth finish and removal of all or part of the initial grinding marks.

4. Summary of Test Method

4.1 An FZG Gear Test Machine is operated at constant speed (1450 rpm) for a fixed period (21700 revolutions—approximately 15 min) at successively increasing loads until the failure criteria is reached; the initial oil temperature is 90 °C beginning at load stage four (see Table 1). The test gears

² For referenced ASTM standards, visit the ASTM website, www.astm.org, or contact ASTM Customer Service at service@astm.org. For *Annual Book of ASTM Standards* volume information, refer to the standard's Document Summary page on the ASTM website.

³ Available from Beuth Verlag GmbH (DIN-- DIN Deutsches Institut für Normung e.V.), Burggrafenstrasse 6, 10787, Berlin, Germany.

*A Summary of Changes section appears at the end of this standard

TABLE 1 Standard Load Stages for FZG Scuffing Test

Load Stage	Torque on Pinion (N·m)	Tooth Normal Force (N)	Hertzian Contact Pressure (N/mm ²)	Total Work Transmitted (kW·h)	Load Clutch Loaded with ^A
1	3.3	99	146	0.19	H1
2	13.7	407	295	0.97	H2
3	35.3	1044	474	2.96	H2+K
4	60.8	1799	621	6.43	H2+K+W1
5	94.1	2786	773	11.8	H2+K+W1+W2
6	135.5	4007	929	19.5	H2+...+W3
7	183.4	5435	1080	29.9	H2+...+W4
8	239.3	7080	1232	43.5	H2+...+W5
9	302.0	8949	1386	60.8	H2+...+W6
10	372.6	11029	1539	82.0	H2+...+W7
11	450.1	13342	1691	107.0	H2+...+W8
12	534.5	15826	1841	138.1	H2+...+W9

^A where:
H1 = load lever H1 (light),
H2 = load lever H2 (heavy),
K = support rod for weights, and
W1 to W9 = weights for loading (supplied with test rig).

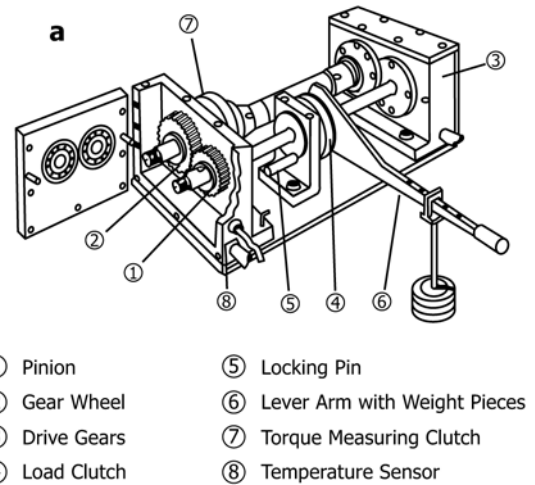

A. Diagram of a Typical FZG Test Rig

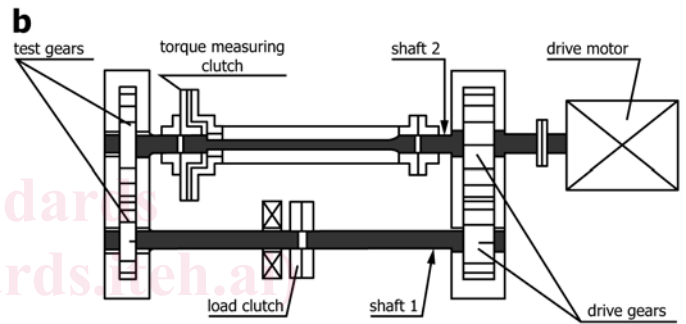

B. Schematic Section of an FZG Test Rig

FIG. 1 FZG Test Rig

are examined initially and after the prescribed duration at each load stage for cumulative damage (scuffing) to the gear tooth flanks.

5. Significance and Use

5.1 The transmission of power in many automotive and industrial applications is accomplished through the use of geared systems. At higher operating speeds it is well known that the lubricant/additive system can be a significant factor in preventing scuffing (adhesive wear) damage to gears. This test method is used to screen the scuffing load capacity of oils used to lubricate spur and helical (parallel axis) gear units.

5.2 The test method is limited by the capabilities of the equipment (test rig and gears), and the performance observed may not directly relate to scuffing performance observed with spiral bevel on hypoid gearing. It is also limited to discriminating between oils with mild EP additives or less. Lubricants containing higher levels of additives, that is, those meeting the requirements of API GL4 or GL5, generally exceed the maximum load capacity of the test rig and, therefore, cannot be distinguished for their scuffing capabilities by this test method.

6. Apparatus

6.1 FZG Gear Test Rig:

6.1.1 A more complete description of the test rig and operating instructions may be found in the instruction manuals available from the manufacturers/suppliers identified in A2.1.2.

6.1.2 The FZG gear test rig utilizes a recirculating power loop principle, also known as a four-square configuration, to provide a fixed torque (load) to a pair of precision test gears. A schematic of the test rig is shown in Fig. 1A and Fig. 1B. The drive gearbox and the test gearbox are connected through two torsional shafts. Shaft 1 contains a load coupling used to apply the torque through the use of known weights hung on the loading arm.

6.1.3 The test gearbox contains heating and cooling elements to maintain and control the temperature of the oil. A temperature sensor located in the side of the test gearbox is used to control the heating/cooling system as required by the test operating conditions.

6.1.4 The test rig is driven by an electric motor capable of delivering at least 5.5 kW at 1440 rpm.

6.2 Test Gears—The test gearset (pinion and gear) are commonly referred to as type A profile and conform to the information supplied in Table 2. A schematic of the profile is shown in Fig. 2. Both sides of the test gear flanks can be used for testing purposes since only one side is loaded during the evaluation. It should be noted that these gears have been designed with a large profile modification which increases their sensitivity to adhesive wear modes of failure.

6.3 Timer Mechanism—A suitable timer or revolution counter must be used to control the number of revolutions during each load stage of the test. The timer should be capable of shutting down the test rig at the appropriate time.

6.4 Hot Plate—A hot plate or suitable heating device is required to warm the gears to 60 °C to 80 °C for assembly on to the shafts.

TABLE 2 Detail Data for the “A” Profile Gears

Parameter	Value	Units
Center Distance	91.5	mm
Effective Tooth Width	20.0	mm
Pitch Circle Diameter:		
Pinion	73.2	mm
Gear	109.8	mm
Tip Diameter:		
Pinion	88.7	mm
Gear	112.5	mm
Module	4.5	mm
Number of Teeth:		
Pinion	16	
Gear	24	
Profile Modification		
Pinion/Gear	0.8635/–0.5103	
Pressure Angle		
Normal/Working	20/22.5	degrees
Hardness		
Rockwell C	60 to 62	
Surface Roughness		
Ra	0.3 to 0.7	μm

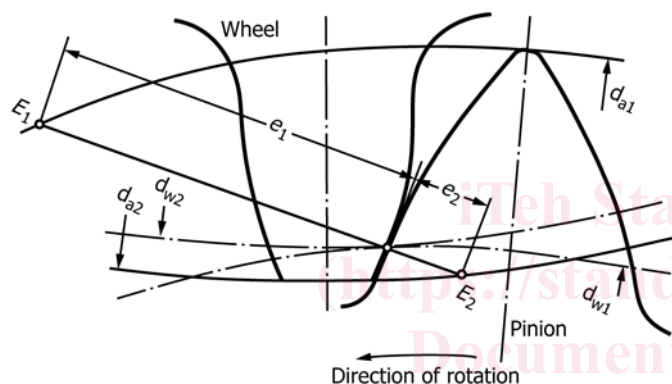

FIG. 2 Schematic of A Profile Test Gears

7. Reagents and Materials

7.1 *Mineral Spirits (Stoddard Solvent)*. (**Warning**—Combustible. Vapor harmful. Keep away from heat, sparks, and open flame (see Annex A1.1). Type I conforming to the requirements outlined in Specification D235.)

8. Hazards

8.1 (**Warning**—This test method involves the use of highly loaded gears and shafts turning at high speeds. Appropriate precautions must be taken to protect personnel (see Annex A1.2).)

9. Preparation of Apparatus

9.1 *Test Gears*—The test gears are cleaned with Stoddard solvent to remove all of the protective coating. In some cases this requires brushing (soft bristle brush) of the gears to remove excess amounts of the coating material. Each gear is to be dried and then visually inspected for any evidence of damage or corrosion on the tooth flank surfaces. In such cases where damage or corrosion is found these gears should not be used for test purposes.

9.2 *Test Gearbox*—The test gearbox and bearings shall be washed thoroughly with Stoddard solvent to remove the previous test oil. (This can be done at the termination of a test

after the oil has been drained from the gearbox and prior to disassembling the test gears.) It is recommended that the gearbox be flushed twice with Stoddard solvent to remove all traces of the previous test oil. After draining the solvent from the test gearbox the unit should be air dried to remove all traces of solvent. (**Warning**—Be sure the gearbox temperature has decreased below 60 °C prior to adding the Stoddard solvent.)

9.3 *Assembly of Test Gears*—The test gears, spacers, and bearings are heated on a hot plate or other device to approximately 60 °C to 80 °C. Install the test gears on the shafts with the alignment marks in the position shown in Fig. 3. Complete the assembly of the gearbox with the appropriate spacers, bearings, and front cover.

9.3.1 It has been found critical for correct results that the test gears are properly aligned on their respective shafts. (**Warning**—Misalignment can lead to erratic or lower fail loads due to uneven distribution of the load on the tooth.)

9.4 *Test Oil*—Add 1.25 L of test oil to the test gearbox (approximately to the centerline of the shafts).

9.5 *Final Assembly*—Secure the top of the test gear case in place with the 6 bolts. Connect the heater to its power source.

10. Procedure

10.1 Prior to starting a test apply load stage 12 to the system for 2 min to 3 min without running the motor (Table 1). This is done to ensure all clearances are in the correct working position. Remove all weights before proceeding to 10.2.

10.2 With the test gears mounted, load clutch locking pin in place, and load clutch bolts loose, apply load stage 1 (see Table 1) to the loading clutch. Tighten the bolts of the load clutch, (the load clutch bolts should be tightened in a star or crosswise pattern to a torque of 100 Nm) remove the weight assembly and lever arm, and remove the load clutch arresting bolt. Start the motor (1450 rpm) and turn on the heaters. Run for 15 min (21700 revolutions), then stop motor.

10.3 Insert the locking pin and loosen the load clutch bolts so that the load is removed from the shafts. Apply load stage 2 according to Table 1. Tighten the bolts of the load clutch, (the load clutch bolts should be tightened in a star or crosswise pattern to a torque of 100 Nm) remove the weights and lever arm, and remove the load clutch locking pin. Start the motor (1450 rpm) and turn on the heaters. After 15 min (21700 revolutions) stop the motor. Repeat this sequence for load stage 3.

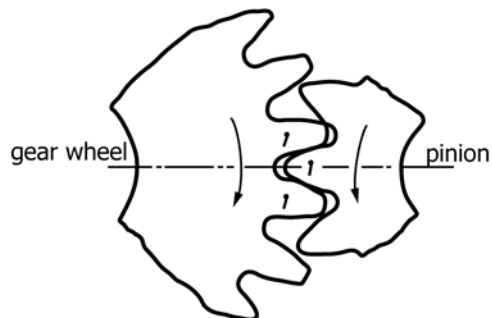

FIG. 3 Marking and Mounting of Test Gears