



Designation: **C657–93 (Reapproved 2013) C657 – 19**

Standard Test Method for D-C Volume Resistivity of Glass¹

This standard is issued under the fixed designation C657; the number immediately following the designation indicates the year of original adoption or, in the case of revision, the year of last revision. A number in parentheses indicates the year of last reapproval. A superscript epsilon (ϵ) indicates an editorial change since the last revision or reapproval.

1. Scope

1.1 This test method covers the determination of the dc volume resistivity of a smooth, preferably polished, glass by measuring the resistance to passage of a small amount of direct current through the glass at a voltage high enough to assure adequate sensitivity. This current must be measured under steady-state conditions that is neither a charging current nor a space-charge, buildup polarization current.

1.2 This test method is intended for the determination of resistivities less than 10^{16} Ω -cm in the temperature range from 25°C to the annealing point of the glass.

1.3 *This standard does not purport to address all of the safety concerns, if any, associated with its use. It is the responsibility of the user of this standard to establish appropriate safety, health, and environmental practices and determine the applicability of regulatory limitations prior to use.* For specific hazard statements, see Section 5.

1.4 *This international standard was developed in accordance with internationally recognized principles on standardization established in the Decision on Principles for the Development of International Standards, Guides and Recommendations issued by the World Trade Organization Technical Barriers to Trade (TBT) Committee.*

2. Referenced Documents

2.1 *ASTM Standards:*²

[D257 Test Methods for DC Resistance or Conductance of Insulating Materials](#)

[D374 Test Methods for Thickness of Solid Electrical Insulation \(Metric\) D0374_D0374M](#)

[D1711 Terminology Relating to Electrical Insulation](#)

[D1829 Test Method for Electrical Resistance of Ceramic Materials at Elevated Temperatures](#) (Withdrawn 2001)³

3. Summary of Test Method

3.1 The dc volume resistance is measured in accordance with Test Methods [D257](#), with the specimen located in a heating chamber with adequate temperature control, electrical shielding and insulation of the sample leads as described in Test Method [D1829](#).

4. Significance and Use

4.1 This experimental procedure yields meaningful data for the dc volume resistivity of glass. It is designed to minimize space charge, buildup polarization effects, and surface conductances. The temperature range is limited to room temperature to the annealing point of the specimen glass.

5. Cautions

5.1 Thermal emfs should be avoided. Connections involving dissimilar metals can cause measurement difficulties. Even copper-copper oxide junctions can produce high thermal emfs. Clean, similar metals should be used for electrical junctions. Platinum is recommended. Welded or crimped connections rather than soldered joints avoid difficulties. Specimen electrodes shall have sufficient cross section for adequate electrical conductance.

¹ This test method is under the jurisdiction of ASTM Committee [C14](#) on Glass and Glass Products and is the direct responsibility of Subcommittee [C14.04](#) on Physical and Mechanical Properties.

Current edition approved Oct. 1, 2013; Nov. 1, 2019. Published October 2013; December 2019. Originally approved in 1970. Last previous edition approved in 2008; 2013 as C657 – 93 (2008); (2013). DOI: [10.1520/C0657-93R13-10.1520/C0657-19](#).

² For referenced ASTM standards, visit the ASTM website, [www.astm.org](#), or contact ASTM Customer Service at [service@astm.org](#). For *Annual Book of ASTM Standards* volume information, refer to the standard's Document Summary page on the ASTM website.

³ The last approved version of this historical standard is referenced on [www.astm.org](#).

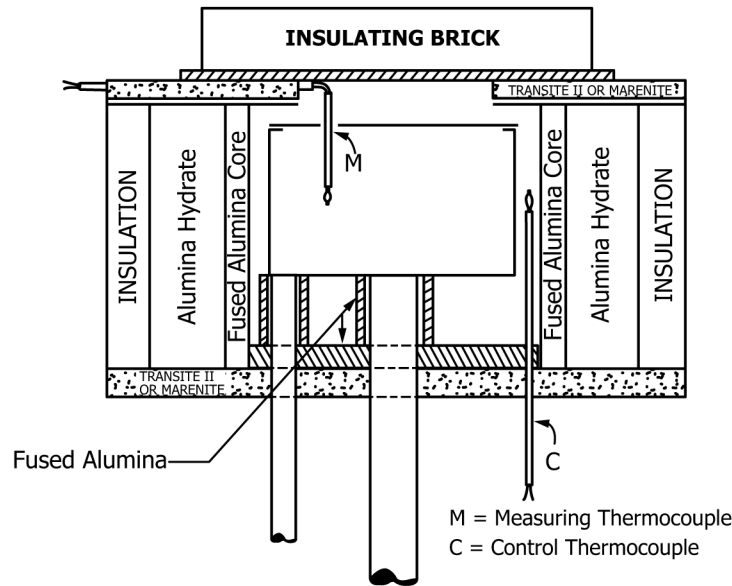

NOTE 1—Heating elements attached to fused alumina core—covered with baked-on refractory cement.

FIG. 1 Heating Chamber

6. Apparatus

6.1 *Resistance-Measuring Devices*, and the possible problems associated with them are discussed thoroughly in Section 97 and Appendixes A1X1 and A3X3 of Test Methods D257. Further discussion of electrometer circuitry is covered in Annex A1 to this test method.

6.2 *Heating Chamber* (Fig. 1)—For heating the specimen, a suitable electric furnace shall be used. The construction of the furnace shall be such that the specimen is subjected to a uniform heat application with a minimum of temperature fluctuation. An adequate muffle should be provided to shield the specimen from direct radiation by the heating elements. This may be made of a ceramic such as aluminum oxide or equivalent. A grounded metallic shield shall also be provided within the furnace, preferably of silver, stainless steel, or equivalent, to isolate electrically the specimen test circuit from the heating element. Furnaces for more than one specimen can be constructed. The control thermocouple may be located in the heating chamber outside the metallic shield, as shown in Fig. 1, or inside the metallic shield.

6.3 *Two Flat Contacting Electrodes*, smaller in diameter than the specimen electrodes (see 7.6), shall be used to sandwich the specimen. Sufficient thickness should be used to maintain an adequate pressure and to provide heat equalization between the specimen and the contacting electrodes.

6.3.1 Fig. 2 shows the specimen setup in the heating chamber. The bottom electrode shall be placed at the end of a metal rod and shall support the specimen in the center of the furnace. The unguarded specimen electrode, No. 3 of Fig. 3, shall be placed in contact with this bottom contacting electrode. The top contacting electrode shall be placed on the guarded, specimen electrode, No. 1 of Fig. 3. This top contacting electrode has leads connected to an off-center metal rod. The specimen guard electrode, No. 2 of Fig. 3, shall be connected to the second off-center metal rod with platinum wire or strap. One end shall be connected to the specimen guard electrode; the other end shall be connected to the metal rod.

6.3.2 All rods should be supported by insulation outside the furnace in a cool zone to minimize electrical leakage at elevated temperatures.

6.3.3 Fig. 4 shows a top view of the specimen setup in the heating chamber.

6.4 *A Temperature-Control System* should be provided so that temperature-time fluctuations within the heating chamber are less than 0.01 T (where T is the temperature in degrees Celsius), during the time interval when resistance measurements are made. Two thermocouples should be used for accurate temperature readings, one in the heating chamber, supplying the emf to the temperature controller and the other on the guard ring of the specimen. The latter should be used to measure the specimen temperature as instructed in the Apparatus section (Temperature-Control Device) of Test Method D1829.

7. Test Specimen

7.1 The Test Specimens section (Volume Resistance or Conductance Determination) of Test Methods D257 describes in detail the specimen requirements. To quote in part, “The test specimen may have any practical form that allows the use of a third electrode, when necessary, to guard against error from surface effects.” For practical reasons, a flat disk or square that is easy to set up in a furnace box is recommended. Other configurations are possible. The descriptions will apply to flat samples but can be

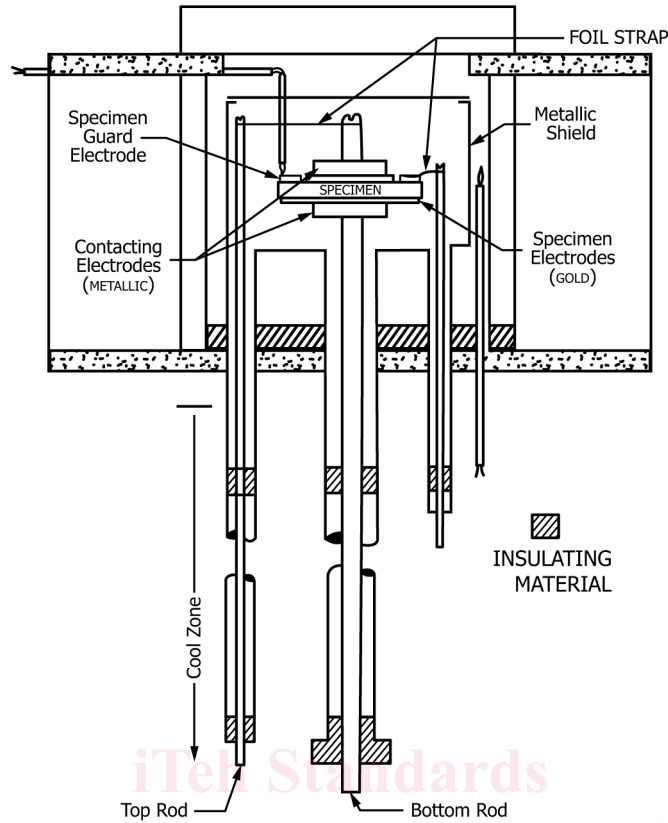

FIG. 2 Specimen Setup for Heating Chamber

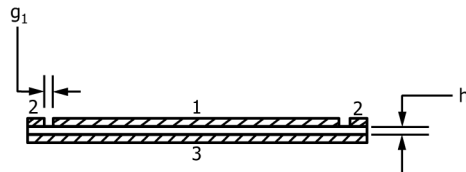
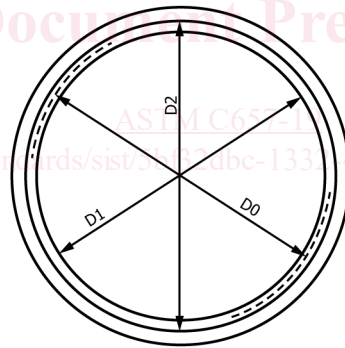

FIG. 3 Glass Specimen with Three-Terminal Electrodes

modified for other configurations. Recommended limitations in the diameter of a disk are 40 to 130 mm. This is not a critical dimension as the effective area of measurements is defined by the area of the applied electrodes, as stated in 7.7.

7.2 As the electrical properties of glass are dependent on the thermal condition of the specimen, this condition should be known and reported.

NOTE 1—The glass could be annealed or have had a special heat treatment which should be clearly defined.