



Standard Practice for Expanded Welded and Silver Brazed Socket Joints for Pipe and Tube¹

This standard is issued under the fixed designation F1076; the number immediately following the designation indicates the year of original adoption or, in the case of revision, the year of last revision. A number in parentheses indicates the year of last reapproval. A superscript epsilon (ϵ) indicates an editorial change since the last revision or reapproval.

^{ε1} NOTE—Keywords section was editorially added in May 2015.

1. Scope-~~Scope~~*

- 1.1 This practice covers expanded welded and silver brazed socket joints for use on shipboard piping systems.
- 1.2 Expanded welded and silver brazed socket joints are to be used to join two pipes or tubes having the same NPS (see **Note 1**) without using a fitting or butt weld.
- 1.3 Brazed socket type joints are not intended for use on systems containing flammable or combustible fluids in areas where fire hazards exist or where the service temperature exceeds 425°F (205°C).
- 1.4 Brazed joints depending solely upon a fillet weld rather than primarily upon brazing material between pipe/tube and socket are not covered by this practice.

NOTE 1—The dimensionless designator nominal pipe size (NPS) has been substituted in this practice for such traditional terms as “nominal diameter,” “size,” “nominal size,” and “iron pipe size.”

1.5 The values stated in inch-pound units are to be regarded as standard. The values given in parentheses are mathematical conversions to SI units that are provided for information only and are not considered standard.

1.6 *This standard does not purport to address all of the safety concerns, if any, associated with its use. It is the responsibility of the user of this standard to establish appropriate safety, health, and environmental practices and determine the applicability of regulatory limitations prior to use.*

1.7 *This international standard was developed in accordance with internationally recognized principles on standardization established in the Decision on Principles for the Development of International Standards, Guides and Recommendations issued by the World Trade Organization Technical Barriers to Trade (TBT) Committee.*

2. Referenced Documents

2.1 ASTM Standards:²

- [A312/A312M Specification for Seamless, Welded, and Heavily Cold Worked Austenitic Stainless Steel Pipes](#)
- [B75B75/B75M Specification for Seamless Copper Tube \(Metric\) B0075_B0075M](#)
- [B88 Specification for Seamless Copper Water Tube](#)
- [B466/B466M Specification for Seamless Copper-Nickel Pipe and Tube](#)

2.2 Military Standards:³

- [MIL-P-1144/MIL-P-24691/3 Pipe, Pipe and Tube, Corrosion-Resistant, Stainless Steel, Seamless and/or Welded](#)
- [MIL-T-16420 Tube, Copper-Nickel Alloy, Seamless and Welded](#)
- [MIL-T-24107 Tube, Copper \(Seamless\)](#)

2.3 ASME Standard:⁴

- [ASME Boiler Code and Pressure Vessel Code, Section IX](#)

¹ This practice is under the jurisdiction of ASTM Committee F25 on Ships and Marine Technology and is the direct responsibility of Subcommittee F25.11 on Machinery and Piping Systems.

Current edition approved May 1, 2015 Dec. 1, 2019. Published June 2015 December 2019. Originally approved in 1987. Last previous edition approved in 2010 as F1076 – 87 (2010) (2015)^{ε1}. DOI: 10.1520/F1076-87R15.10.1520/F1076-19.

² For referenced ASTM standards, visit the ASTM website, www.astm.org, or contact ASTM Customer Service at service@astm.org. For *Annual Book of ASTM Standards* volume information, refer to the standard's Document Summary page on the ASTM website.

³ Available from U.S. Government Printing Office, Superintendent of Documents, 732 N. Capitol St., NW, Mail Stop: SDE, Washington, DC 20401-20401-0001, http://www.access.gpo.gov.

⁴ Available from American Society of Mechanical Engineers (ASME), ASME International Headquarters, Two Park Ave., New York, NY 10016-5990, http://www.asme.org.

*A Summary of Changes section appears at the end of this standard

2.4 *Federal Standard*:³

[Title 46 Code of Federal Regulations](#), [Code of Federal Regulations Title 46](#)

2.5 *NAVSEA Document*:³

[0900-LP-001-7000 Fabrication and Inspection of Brazed Piping Systems](#)

3. Significance and Use

3.1 Expanded welded socket joints may be used with the following pipe and tube:

3.1.1 *Seamless Copper Tube*—2.375-in. (60-mm) outside diameter through 6.625-in. (170-mm) outside diameter.

3.1.2 *Seamless Copper-Nickel Tube*—2.375-in. (60-mm) outside diameter through 6.625-in. (170-mm) outside diameter.

3.1.3 *Seamless Copper Water Tube*—2.125-in. (55-mm) outside diameter through 4.125-in. (105-mm) outside diameter.

3.1.4 *Seamless Stainless Steel Pipe*—2 NPS through 6 NPS, Schedules 5 and 10.

3.2 Expanded silver brazed socket joints may be used with the following tube:

3.2.1 *Seamless Copper Tube*—2.375-in. (60-mm) outside diameter through 6.625-in. (170-mm) outside diameter.

3.2.2 *Seamless Copper-Nickel Tube*—2.375-in. (60-mm) outside diameter through 6.625-in. (170-mm) outside diameter.

3.2.3 *Seamless Copper Water Tube*—2.125-in. (55-mm) outside diameter through 4.125-in. (105-mm) outside diameter.

3.3 Expanded welded and silver brazed socket joints may be used where experience or test has demonstrated that the joint is safe and suitable for design and operating conditions, and where adequate provision is made to prevent separation of the joint.

4. Materials and Manufacture

4.1 *Welded Socket Joint*:

4.1.1 *Seamless Copper Tube*—Specification [B75B75/B75M](#), UNS Number C12200 and MIL-T-24107, UNS Number C12200, light drawn (see 5.3).

4.1.2 *Seamless Copper-Nickel Tube (90-10)*—Specification [B466/B466M](#), UNS Number C70600 and MIL-T-16420, UNS Number C70600, Class 200, annealed.

4.1.3 *Seamless Copper-Nickel Tube (70-30)*—Specification [B466/B466M](#), UNS Number C71500 and MIL-T-16420, UNS Number C71500, Class 200, annealed.

4.1.4 *Seamless Copper Water Tube*—Specification [B88](#), Type K, UNS Number C71500, drawn (see 5.3).

4.1.5 *Seamless Stainless Steel Pipe*—Specification [A312/A312M](#), UNS Number S30400 and ~~S31600~~, [MIL-P-1144](#), [S31600](#), [MIL-P-24691/3](#), UNS Number S30400 and S31600, Schedules 5 and 10.

4.2 *Silver-Brazed Socket Joint*:

4.2.1 *Seamless Copper Tube*—Specification [B75B75/B75M](#), UNS Number C12200 and MIL-T-24107, UNS Number C12200, light drawn (see 5.3).

4.2.2 *Seamless Copper-Nickel Tube (90-10)*—Specification [B466/B466M](#), UNS Number C70600 and MIL-T-16420, UNS Number C70600, Class 200, annealed.

4.2.3 *Seamless Copper-Nickel Tube (70-30)*—Specification [B466/B466M](#), UNS Number C71500 and MIL-T-16420, UNS Number C71500, Class 200, annealed.

4.2.4 *Seamless Copper Water Tube*—Specification [B88](#), Type K, UNS Number C12200, drawn (see 5.3).

5. Procedure

5.1 Install no more than two expanded joints in any 36-in. (915-mm) long section of pipe/tube and in no case allow a pipe/tube expanded at both ends in lengths of less than 36 in.

5.2 Fabricate expanded joints on the ends of the pipe/tube by use of an expanding machine.

5.3 Expanded joints shall not be used on Class I piping systems as defined in 46CFR56.04 for United States Coast Guard inspected and certified vessels.

5.4 Perform a minimum of three expansions to ensure the degree of expansion.

5.5 Bevel the unexpanded end of pipe/tube 30 to 40° for copper-nickel alloy and 10 to 20° for stainless steel.

5.6 Clean the pipe/tube ends to be inserted into the silver-brazed expanded pipe/tube socket and the interior of the socket itself to a bright metal before insertion.

5.7 Align pipe/tube ends concentrically as accurately as possible, and preserve this alignment during the welding process.

5.8 Provide a gap of approximately 1/16 in. (1.5 mm) (expanded welded socket joint, [Fig. 1](#)) and 1/8 in. (3 mm) (expanded silver-brazed joint, [Fig. 2](#)) between the end of the pipe/tube and the bottom of the socket by bottoming the pipe/tube and backing off slightly before tacking.

5.9 The minimum insertion length shall be 1 in. (25 mm).

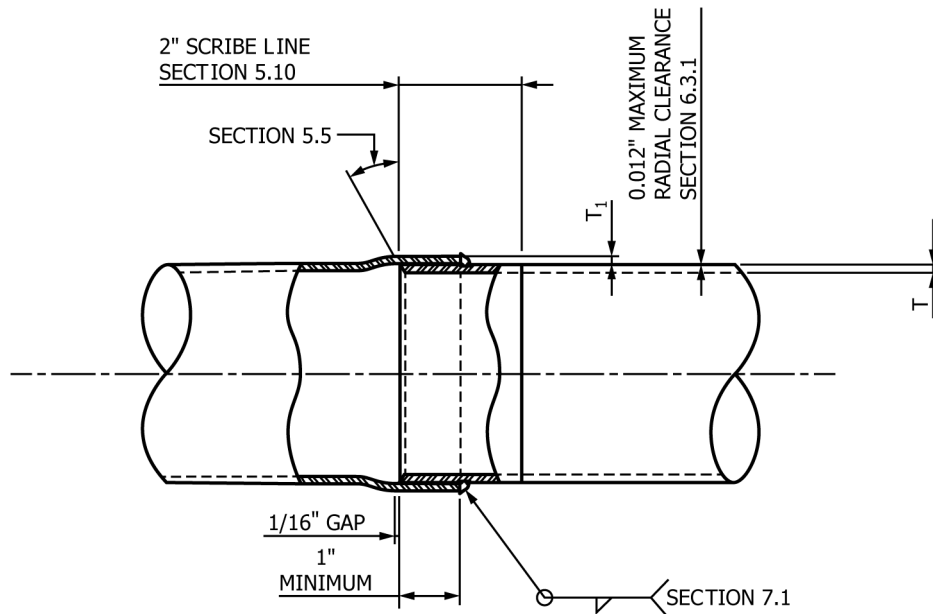

NOTE 1—1 in. = 25.4 mm.

FIG. 1 Expanded Welded Socket Joint

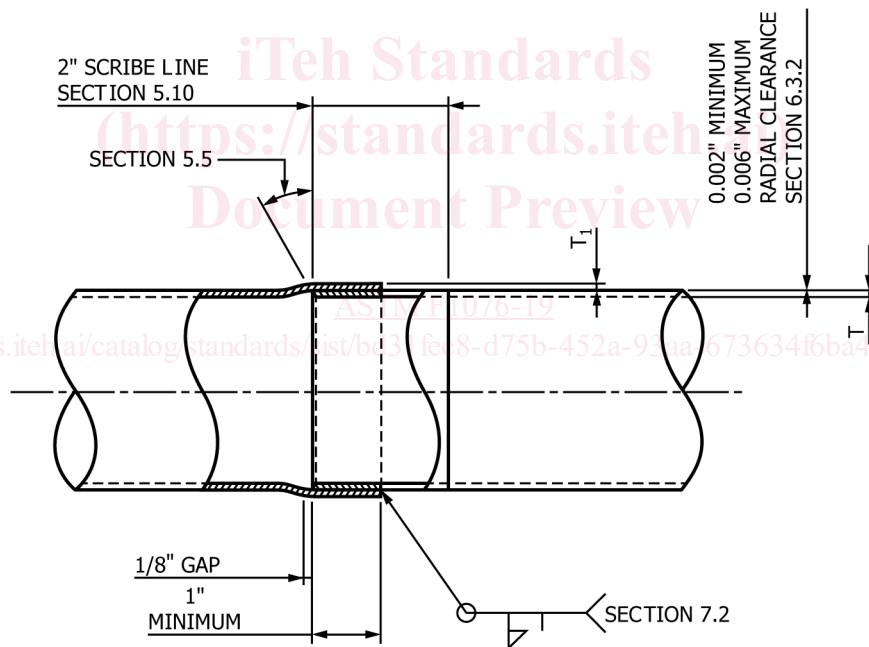

NOTE 1—1 in. = 25.4 mm.

FIG. 2 Expanded Silver-Brazed Joint

5.10 For United States Navy Application (see NAVSEA Document 0900-LP-001-7000), on the pipe/tube inserted into the expanded joint make a light scribe line a distance of 2 in. (50 mm) from the end of the unexpanded pipe/tube. This scribe line shall be visible at the time of final inspection.

5.11 The filler metal used in brazing shall be a nonferrous metal or alloy having a melting point above 1000°F (537°C) and below that of the metal being joined.

5.12 The brazing material shall have a shearing strength of at least 10 000 psi (68 950 KPa).

6. Dimensions and Tolerances

6.1 Dimensions are as indicated in Fig. 1.