



Designation: ~~D8111 – 19a~~ **D8111 – 19b**

Standard Test Method for Evaluation of Automotive Engine Oils in the Sequence IIH, Spark-Ignition Engine¹

This standard is issued under the fixed designation D8111; the number immediately following the designation indicates the year of original adoption or, in the case of revision, the year of last revision. A number in parentheses indicates the year of last reapproval. A superscript epsilon (ϵ) indicates an editorial change since the last revision or reapproval.

INTRODUCTION

Portions of this test method are written for use by laboratories that make use of ASTM Test Monitoring Center (TMC)² services (see [Annex A1](#)).

The TMC provides reference oils, and engineering and statistical services to laboratories that desire to produce test results that are statistically similar to those produced by laboratories previously calibrated by the TMC.

In general, the test purchaser decides if a calibrated test stand is to be used. Organizations such as the American Chemistry Council require that a laboratory utilize the TMC services as part of their test registration process. In addition, the American Petroleum Institute and the Gear Lubricant Review Committee of the Lubricant Review Institute (SAE International) require that a laboratory use the TMC services in seeking qualification of oils against their specifications.

The advantage of using the TMC services to calibrate test stands is that the test laboratory (and hence the test purchaser) has an assurance that the test stand was operating at the proper level of test severity. It should also be borne in mind that results obtained in a non-calibrated test stand may not be the same as those obtained in a test stand participating in the ASTM TMC services process.

ASTM International policy is to encourage the development of test procedures based on generic equipment. It is recognized that there are occasions where critical/sole-source equipment has been approved by the technical committee (surveillance panel/task force) and is required by the test procedure. The technical committee that oversees the test procedure is encouraged to clearly identify if the part is considered critical in the test procedure. If a part is deemed to be critical, ASTM encourages alternative suppliers to be given the opportunity for consideration of supplying the critical part/component providing they meet the approval process set forth by the technical committee.

An alternative supplier can start the process by initiating contact with the technical committee (current chairs shown on ASTM TMC website). The supplier should advise on the details of the part that is intended to be supplied. The technical committee will review the request and determine feasibility of an alternative supplier for the requested replacement critical part. In the event that a replacement critical part has been identified and proven equivalent the sole-source supplier footnote shall be removed from the test procedure.

1. Scope*

1.1 This test method covers an engine test procedure for evaluating automotive engine oils for certain high-temperature performance characteristics, including oil thickening (as measured by kinematic viscosity increase), piston deposits, ring sticking, oil consumption, and phosphorus retention. Such oils include both single-viscosity and multiviscosity grade oils that are used in both spark-ignition, gasoline-fueled engines, as well as in diesel engines.

¹ This test method is under the jurisdiction of ASTM Committee [D02](#) on Petroleum Products, Liquid Fuels, and Lubricants and is the direct responsibility of Subcommittee [D02.B0](#) on Automotive Lubricants.

Current edition approved ~~Nov. 1, 2019~~ Dec. 1, 2019. Published ~~November 2019~~ January 2019. Originally approved in 2017. Last previous edition approved in 2019 as ~~D8111 – 19-D8111 – 19a~~. DOI: ~~10.1520/D8111-19A~~ 10.1520/D8111-19B.

² Until the next revision of this test method, the ASTM Test Monitoring Center will update changes in the test method by means of information letters. Information letters may be obtained from the ASTM Test Monitoring Center, 6555 Penn Avenue, Pittsburgh, PA 15206-4489, Attention Administrator. This edition incorporates revisions in all information letters through No. ~~49-3-19-4~~.

*A Summary of Changes section appears at the end of this standard

1.1.1 Additionally, with nonmandatory supplemental requirements, a Sequence IIIHA Test (Mini Rotary Viscometer and Cold Cranking Simulator measurements), or a Sequence IIIHB Test (phosphorus retention measurement) can be conducted. These supplemental test procedures are contained in [Appendix X1](#) and [Appendix X2](#), respectively.

NOTE 1—Companion test methods used to evaluate engine oil performance for specification requirements are discussed in SAE J304.

1.2 The values stated in SI units are to be regarded as standard. No other units of measurement are included in this standard.

1.2.1 *Exceptions:*

1.2.1.1 Where there is no direct SI equivalent such as screw threads, national pipe threads/diameters, tubing sizes, and valve sizes and springs.

1.2.1.2 The ring end gaps in [Table A8.7](#), the dimensions for the blowby ventilation support bracket in [Fig. A3.2](#), and the torque wrenches in [Table A8.1](#) are in inch-pound units.

1.3 *This standard does not purport to address all of the safety concerns, if any, associated with its use. It is the responsibility of the user of this standard to establish appropriate safety, health, and environmental practices and determine the applicability of regulatory limitations prior to use.* Specific warning statements are provided in [6.11.6](#), [7.1](#), [7.2.1](#), and [7.3](#).

1.4 *This international standard was developed in accordance with internationally recognized principles on standardization established in the Decision on Principles for the Development of International Standards, Guides and Recommendations issued by the World Trade Organization Technical Barriers to Trade (TBT) Committee.*

2. Referenced Documents

2.1 *ASTM Standards:*³

- [D86 Test Method for Distillation of Petroleum Products and Liquid Fuels at Atmospheric Pressure](#)
- [D130 Test Method for Corrosiveness to Copper from Petroleum Products by Copper Strip Test](#)
- [D235 Specification for Mineral Spirits \(Petroleum Spirits\) \(Hydrocarbon Dry Cleaning Solvent\)](#)
- [D240 Test Method for Heat of Combustion of Liquid Hydrocarbon Fuels by Bomb Calorimeter](#)
- [D323 Test Method for Vapor Pressure of Petroleum Products \(Reid Method\)](#)
- [D381 Test Method for Gum Content in Fuels by Jet Evaporation](#)
- [D445 Test Method for Kinematic Viscosity of Transparent and Opaque Liquids \(and Calculation of Dynamic Viscosity\)](#)
- [D525 Test Method for Oxidation Stability of Gasoline \(Induction Period Method\)](#)
- [D664 Test Method for Acid Number of Petroleum Products by Potentiometric Titration](#)
- [D1319 Test Method for Hydrocarbon Types in Liquid Petroleum Products by Fluorescent Indicator Adsorption](#)
- [D2699 Test Method for Research Octane Number of Spark-Ignition Engine Fuel](#)
- [D2700 Test Method for Motor Octane Number of Spark-Ignition Engine Fuel](#)
- [D3231 Test Method for Phosphorus in Gasoline](#)
- [D3237 Test Method for Lead in Gasoline by Atomic Absorption Spectroscopy](#)
- [D3244 Practice for Utilization of Test Data to Determine Conformance with Specifications](#)
- [D3338 Test Method for Estimation of Net Heat of Combustion of Aviation Fuels](#)
- [D3343 Test Method for Estimation of Hydrogen Content of Aviation Fuels](#)
- [D4052 Test Method for Density, Relative Density, and API Gravity of Liquids by Digital Density Meter](#)
- [D4175 Terminology Relating to Petroleum Products, Liquid Fuels, and Lubricants](#)
- [D4485 Specification for Performance of Active API Service Category Engine Oils](#)
- [D4684 Test Method for Determination of Yield Stress and Apparent Viscosity of Engine Oils at Low Temperature](#)
- [D4739 Test Method for Base Number Determination by Potentiometric Hydrochloric Acid Titration](#)
- [D4815 Test Method for Determination of MTBE, ETBE, TAME, DIPE, tertiary-Amyl Alcohol and C₁ to C₄ Alcohols in Gasoline by Gas Chromatography](#)
- [D5185 Test Method for Multielement Determination of Used and Unused Lubricating Oils and Base Oils by Inductively Coupled Plasma Atomic Emission Spectrometry \(ICP-AES\)](#)
- [D5191 Test Method for Vapor Pressure of Petroleum Products and Liquid Fuels \(Mini Method\)](#)
- [D5293 Test Method for Apparent Viscosity of Engine Oils and Base Stocks Between –10 °C and –35 °C Using Cold-Cranking Simulator](#)
- [D5452 Test Method for Particulate Contamination in Aviation Fuels by Laboratory Filtration](#)
- [D5453 Test Method for Determination of Total Sulfur in Light Hydrocarbons, Spark Ignition Engine Fuel, Diesel Engine Fuel, and Engine Oil by Ultraviolet Fluorescence](#)
- [D7320 Test Method for Evaluation of Automotive Engine Oils in the Sequence IIIG, Spark-Ignition Engine](#)
- [D8047 Test Method for Evaluation of Engine Oil Aeration Resistance in a Caterpillar C13 Direct-Injected Turbocharged Automotive Diesel Engine](#)

³ For referenced ASTM standards, visit the ASTM website, www.astm.org, or contact ASTM Customer Service at service@astm.org. For *Annual Book of ASTM Standards* volume information, refer to the standard's Document Summary page on the ASTM website.

E29 Practice for Using Significant Digits in Test Data to Determine Conformance with Specifications
 E168 Practices for General Techniques of Infrared Quantitative Analysis
 E191 Specification for Apparatus For Microdetermination of Carbon and Hydrogen in Organic and Organo-Metallic Compounds

2.2 SAE Standards:⁴

J183 Engine Oil Performance and Engine Service Classification (Other Than “Energy-Conserving”)

J300 Engine Oil Viscosity Classification

J304 Engine Oil Tests *HS-23/00*

2.3 Other ASTM Documents:

Guidelines for Calibration⁵

The Lubricant Test Monitoring System, Sequence IIIH Test Control Chart Technique for Developing and Applying Severity Adjustments (SA)⁶

ASTM Deposit Rating Manual No. 20 (Formerly CRC Manual 20)⁷

2.4 Other Standards:

MIL-PRF-2104 Performance Specification: Lubricating Oil, Internal Combustion Engine, Combat/Tactical Service⁸

3. Terminology

3.1 Definitions:

3.1.1 *air-fuel ratio, n*—in internal combustion engines, the mass ratio of air-to-fuel in the mixture being induced into the combustion chambers. **D4175**

3.1.2 *automotive, adj*—descriptive of equipment associated with self-propelled machinery, usually vehicles driven by internal combustion engines. **D4175**

3.1.3 *blowby, n*—in internal combustion engines, that portion of the combustion products and unburned air/fuel mixture that leaks past piston rings into the engine crankcase during operation. **D4175**

3.1.4 *calibrate, v*—to determine the indication or output of a device (e.g., thermometer, manometer, engine) with respect to that of a standard. **D4175**

3.1.5 *calibrated test stand, n*—a test stand on which the testing of reference material(s), conducted as specified in the standard, provided acceptable test results. **D4175**

3.1.5.1 Discussion—

In several automotive lubricant standard test methods, the ASTM Test Monitoring Center provides testing guidance and determines acceptability. **D4175**

3.1.6 *cold-stuck piston ring, n*—in internal combustion engines, a piston ring that is stuck when the piston and ring are at room temperature, but inspection shows that it was free during engine operation. **D4175**

3.1.6.1 Discussion—

A cold-stuck piston ring cannot be moved with moderate finger pressure. It is characterized by a polished face over its entire circumference, indicating essentially no blowby passed over the outside of the ring during operation. **D4175**

3.1.7 *corrosion, n*—the chemical or electrochemical reaction between a material, usually a metal surface, and its environment that can produce a deterioration of the material and its properties. **D4175**

3.1.8 *engine oil, n*—a liquid that reduces friction or wear, or both, between the moving parts within an engine; removes heat, particularly from the underside of pistons; and serves as a combustion gas sealant for piston rings.

3.1.8.1 Discussion—

It may contain additives to enhance certain properties. Inhibition of engine rusting, deposit formation, valve train wear, oil oxidation, and foaming are examples. **D4175**

3.1.9 *hot-stuck piston ring, n*—in internal combustion engines, a piston ring that is stuck when the piston and ring are at room temperature, and inspection shows that it was stuck during engine operation.

⁴ Available from SAE International (SAE), 400 Commonwealth Dr., Warrendale, PA 15096, <http://www.sae.org>.

⁵ Guidelines for Calibration can be found in the Lubricant Test Monitoring System, available from the Test Monitoring Center, <http://www.astmtmc.cmu.edu>.

⁶ Available at: <ftp://ftp.astmtmc.cmu.edu>.

⁷ Available as stock #TMCNML20 at www.astm.org, or contact ASTM Customer Service at service@astm.org.

⁸ Available from U.S. Government Printing Office, Superintendent of Documents, 732 N. Capitol St., NW, Washington, DC 20401-0001, <http://www.access.gpo.gov>.

3.1.9.1 Discussion—

The portion of the ring that is stuck cannot be moved with moderate finger pressure. A hot-stuck ring is characterized by varnish or carbon across a portion of its face, indicating that portion of the ring was not contacting the cylinder wall during engine operation. **D4175**

3.1.10 *lubricant test monitoring system (LTMS)*, *n*—an analytical system in which ASTM calibration test data are used to manage lubricant test precision and severity (bias). **D4175**

3.1.11 *lubricant*, *n*—any material interposed between two surfaces that reduces the friction or wear, or both, between them. **D4175**

3.1.12 *mass fraction of B*, w_B , *n*—mass of a component B in a mixture divided by the total mass of all the constituents of the mixture.

3.1.12.1 Discussion—

Values are expressed as pure numbers or the ratio of two units of mass (for example, mass fraction of lead is $w_B = 1.3 \times 10^{-6} = 1.3 \text{ mg/kg}$). **D8047**

3.1.13 *Material Safety Data Sheet (MSDS)*, *n*—a fact sheet summarizing information about material identification; hazardous ingredients; health, physical, and fire hazards; first aid; chemical reactivities and incompatibilities; spill, leak, and disposal procedures; and protective measures required for safe handling and storage. **http://www.msdssearch.com**

3.1.14 *non-reference oil*, *n*—any oil, other than a reference oil; such as a research formulation, commercial oil, or candidate oil. **D4175**

3.1.15 *oxidation*, *n*—of engine oil, the reaction of the oil with an electron acceptor, generally oxygen, that can produce deleterious acidic or resinous materials often manifested as sludge formation, varnish formation, viscosity increase, or corrosion, or a combination thereof. **D4175**

3.1.16 *quality index (QI)*, *n*—a mathematical formula that uses data from controlled parameters to calculate a value indicative of control performance. **D4175**

3.1.17 *Quantity*, *n*—*in the SI*, a measurable property of a body or substance where the property has a magnitude expressed as the product of a number and a unit; there are seven, well-defined base quantities (length, time, mass, temperature, amount of substance, electric current, and luminous intensity) from which all other quantities are derived (for example, volume whose SI unit is the cubic metre).

3.1.17.1 Discussion—

Symbols for quantities must be carefully defined; are written in italic font, can be upper or lower case, and can be qualified by adding further information in subscripts, or superscripts, or in parentheses (for example, $t_{\text{fuel}} = 40 \text{ }^\circ\text{C}$, where *t* is used as the symbol for the quantity Celsius temperature and t_{fuel} is the symbol for the specific quantity fuel temperature). **D8047**

3.1.18 *reference oil*, *n*—an oil of known performance characteristics, used as a basis for comparison.

3.1.18.1 Discussion—

Reference oils are used to calibrate testing facilities, to compare the performance of other oils, or to evaluate other materials (such as seals) that interact with oils. **D4175**

3.1.19 *standard test*, *n*—a test on a calibrated test stand, using the prescribed equipment according to the requirements in the test method, and conducted according to the specified operating conditions. **D4175**

3.1.20 *special parts supplier (SPS)*, *n*—the manufacturer and supplier of many of the parts and fixtures used in this test method. **D7320**

3.1.21 *test oil*, *n*—any oil subjected to evaluation in an established procedure.

3.1.21.1 Discussion—

It can be any oil selected by the laboratory conducting the test. It could be an experimental product or a commercially available oil. Often, it is an oil that is a candidate for approval against engine oil specifications (such as manufacturers' or military specifications, etc.) **D4175**

3.1.22 *test parameter*, *n*—a specified component, property, or condition of a test procedure.

3.1.22.1 Discussion—

Examples of *components* are fuel, lubricant, reagent, cleaner, and sealer; of *properties* are density, temperature, humidity, pressure, and viscosity; and of *conditions* are flow rate, time, speed, volume, length, and power. **D4175**

3.1.23 *test procedure, n*—one where test parameters, apparatus, apparatus preparation, and measurements are principal items specified. **D4175**

3.1.24 *test stand, n*—a suitable foundation (such as a bedplate) to which is mounted a dynamometer, and which is equipped with a suitable data acquisition system, fluids process control system, supplies of electricity, compressed air, and so forth, to provide a means for mounting and operating an engine in order to conduct a Sequence IIIH engine oil test. **D7320**

3.1.25 *used oil, n*—any oil that has been in a piece of equipment (for example, an engine, gearbox, transformer, or turbine), whether operated or not. **D4175**

3.1.26 *varnish, n*—in internal combustion engines, a hard, dry, generally lustrous, deposit that can be removed by solvents but not by wiping with a cloth. **D4175**

3.1.27 *volume fraction of B, ϕ_B , n*—volume of component B divided by the total volume of the all the constituents of the mixture prior to mixing.

3.1.27.1 Discussion—

Values are expressed as pure numbers or the ratio of two units of volume (for example, $\phi_B = 0.012 = 1.2\% = 1.2 \text{ cL/L}$). **D8047**

3.2 Definitions of Terms Specific to This Standard:

3.2.1 *build-up oil, n*—EF-411, non-compounded, ISO VG 32 (SAE 10) oil used in lubricating some of the Sequence IIIH parts during engine assembly.

3.2.2 *central parts distributor (CPD), n, n*—the manufacturer and supplier of many of the parts and fixtures used in this test method.

3.2.2.1 Discussion—

Because of the need for rigorous inspection and control of many of the parts used in this test method, and because of the need for careful manufacture of special parts and fixtures used, companies having the capabilities to provide the needed services have been selected as the official suppliers for the Sequence IIIH test method. These companies work closely with the original parts suppliers, with the Test Procedure Developer, and with the ASTM groups associated with the test method to help ensure that the equipment and materials used in the method function satisfactorily. **D7320**

3.2.3 *reference oil test, n*—a standard Sequence IIIH engine oil test of a reference oil designated by the TMC.

3.2.4 *test procedure developer, n*—the group or agency which developed the Sequence IIIH test procedure before its standardization by ASTM, and which continues to be involved with the test in respect to modifications in the test method, development of Information Letters, supply of test parts, and so forth.

3.2.4.1 Discussion—

In the case of the Sequence IIIH test, the Test Procedure Developer is the Chrysler Technology Center.

3.2.5 *test start, n*—introduction of test oil into the engine after the final assembly and mounting in the test stand. **D7320**

3.3 Acronyms:

3.3.1 ACC—American Chemical Society

3.3.2 AFR—air fuel ratio

3.3.3 APP—accelerator pedal position

3.3.4 AWG—American wire gauge

3.3.5 CCS—cold cranking simulator

3.3.6 CPD—central parts distributor

3.3.7 DAQ—data acquisition

3.3.8 dc—direct current

3.3.9 ECM—engine control module

3.3.10 ECU—electronic control unit

- 3.3.11 EOT—end of test
- 3.3.12 FCM—fluid conditioning module
- 3.3.13 FTIR—Fourier transform infrared
- 3.3.14 ICP-AES—inductively coupled plasma-atomic emission spectrometry
- 3.3.15 ID—internal diameter
- 3.3.16 LTMS—lubricant test monitoring system
- 3.3.17 M—the detergent metal with the highest concentration in the fresh oil
- 3.3.18 MRV—mini-rotary viscometer
- 3.3.19 MSDS—material safety data sheet
- 3.3.20 NM—not measured
- 3.3.21 OE—original equipment
- 3.3.22 PCM—powertrain control module
- 3.3.23 P/N—part number
- 3.3.24 PTFE—polytetrafluoroethylene
- 3.3.25 RTV Silicone—room temperature vulcanization silicone
- 3.3.26 SA—severity adjustment
- 3.3.27 SAE—Society of Automotive Engineers
- 3.3.28 SOT—start of test
- 3.3.29 SPS—special parts supplier
- 3.3.30 TAN—total acid number
- 3.3.31 TBN—total base number
- 3.3.32 TMC—Test Monitoring Center
- 3.3.33 TR—test result
- 3.3.34 TVTM—too viscous to measure
- 3.3.35 WPD—weighted piston deposit

3.4 *Quantity Symbols:*

- 3.4.1 F_C —corrected blowby flow rate (11.8.3)
- 3.4.2 F_M —measured blowby flow rate (11.8.3)
- 3.4.3 i —quantity measured in the test (10.4.6)
- 3.4.4 ip —intermediate precision limit (14.1.2.1)
- 3.4.5 L_i —the lower-specification limit for the measured quantity i (10.4.6)
- 3.4.6 n —the total number of data points taken (10.4.6)
- 3.4.7 p —pressure at the exit of the blowby canister (11.8.3)
- 3.4.8 P_{ret} —phosphorus retention (X2.5.1.3)
- 3.4.9 QI —quality index (10.4.6)
- 3.4.10 R —reproducibility limit (14.1.3.1)
- 3.4.11 S —estimated standard deviation (Table 7, footnote D)
- 3.4.12 t —Celsius temperature at the exit of the blowby canister (11.8.3)
- 3.4.13 U_i —the upper-specification limit for the measured quantity i (10.4.6)
- 3.4.14 $w(M_{EOT})$ —mass fraction of metal M at EOT (X2.5.1.3)
- 3.4.15 $w(M_I)$ —mass fraction of metal M in the initial oil sample (X2.5.1.3)
- 3.4.16 $w(P_{EOT})$ —mass fraction of phosphorus in the EOT sample (X2.5.1.3)
- 3.4.17 $w(P_I)$ —mass fraction of phosphorus in the initial oil sample (X2.5.1.3)
- 3.4.18 X_i —the recorded value for the measured quantity i (10.4.6)

4. Summary of Test Method

4.1 A Chrysler Pentastar V-6 test engine with a displacement of 3.6 L is disassembled, honed, solvent-cleaned, measured, and rebuilt using new parts installed as specified in this test method.

4.2 The engine is installed on a test stand equipped with an appropriate data acquisition system, the required fluids process control system, and all necessary accessories for controlling speed, torque, and various other operating test parameters.

4.3 The engine is charged with the test oil.

4.4 The engine is operated for an initial run-in period of 8 min to check all test stand operating systems and to establish a zero-hour, oil-level reading. An oil sample is also taken to allow the measurement of the initial oil viscosity.

4.5 The initial oil level in the oil pan is determined after the 8 min initial run-in, and subsequent oil-level calculations are determined during the oil-leveling period at the end of each 20 h segment.

4.6 Following the run-in and oil-leveling period of 8 min, the engine is ramped up to test conditions over a 5 min period, then operated under non-cyclic conditions, at moderately high-speed and torque, and at specified temperatures for 90 h, in four 20 h segments and one 10 h segment.

4.7 Used-oil samples are taken after the 8 min initial run-in, after each 20 h test segment and at the end of test (EOT); kinematic viscosity at 40 °C is determined for each of the six samples; the percentage change in viscosity of the five latter samples is determined relative to the viscosity of the first used-oil sample (8 min initial run-in).

4.8 The EOT sample is also used to determine the apparent viscosity in the minirotary viscometer (which is required for the nonmandatory Sequence IIIHA test) and the phosphorus retention of the test lubricant after 90 h Sequence IIIH test operation (which is required for the nonmandatory Sequence IIIHB test).

4.9 At the conclusion of the test, the engine is disassembled and the parts are visually rated to determine the extent of deposits formed.

5. Significance and Use

5.1 This test method was developed to evaluate automotive engine oils for protection against oil thickening and piston deposits during moderately high-speed, hightemperature service.

5.1.1 The increase in kinematic viscosity of the oil indicates the tendency of an oil to thicken because of oxidation. In automotive service, such thickening can cause oil pump starvation and resultant catastrophic engine failures.

5.1.2 The deposit ratings for an oil indicate the tendency for the formation of deposits throughout the engine, including those that can cause sticking of the piston rings in their grooves. In automotive service, such ring sticking can cause a loss of compression pressures in the engine.

5.2 The test method was developed to correlate with oils of known good and poor protection against oil thickening and piston deposits. Specially formulated oils that produce less than desirable results with unleaded fuels were also used during the development of this test.

5.3 The Sequence IIIH engine oil test has been recommended as a replacement for the Sequence IIIG test and is expected to be used in specifications and classifications of engine lubricating oils, such as the following:

5.3.1 Specification **D4485**.

5.3.2 Military Specification MIL-PRF-2104.

5.3.3 SAE Classification J183.

6. Apparatus

6.1 *Laboratory*—Observe the following laboratory conditions to ensure good control of test operations and good repeatability:

6.1.1 Maintain the ambient laboratory atmosphere relatively free of dirt, dust, and other contaminants.

6.1.2 Filter the air in the engine build-up area, and control its temperature and humidity to prevent accumulation of dirt or rust on engine parts.

6.1.3 If an engine is assembled in an area of controlled environment and moved to a non-controlled area, provide suitable protection of the engine so that moist air cannot enter the engine and promote rusting before the test.

6.1.4 A fan is required to be installed to direct air flow on or near the electronic components in the exhaust system; but air (hot or cold) is not permitted to be directed onto other engine surfaces during test operation.

6.2 *Specified Equipment*:

6.2.1 Use the equipment specified in the procedure (see **Tables 1-3**) whenever possible. Substitution of equivalent equipment is allowed, but only after equivalency has been proven to the satisfaction of the TMC, the Test Procedure Developer (see **3.2.4.1**) and the ASTM Sequence IIIH Surveillance Panel.

6.2.2 Do not use heat lamps or fans directed at the engine and do not use insulation on the engine for oil or coolant temperature control.

6.2.2.1 For operator safety and the protection of test components, the use of shielding and insulation on the exhaust system may be incorporated downstream of the oxygen sensor elbow.

6.2.2.2 To minimize the temperature effects on electronic components near the exhaust system, place a fan with an output less than 140 L/s at the front of the engine with the air flow directed toward the exhaust pipes, parallel to the driveshaft. Place fan at a minimum of 35 cm from the centerline of the harmonic balancer.

6.2.3 For operator safety and the protection of test components, the use of shielding and insulation on the exhaust system may be incorporated downstream of the oxygen sensor elbow.

TABLE 1 Control-System/Engine-Interface Components

Component Description	Part Number	Supplier ^A
Pump, water, modified, Seq. IIH Chrysler	OHT3H-300-1	OH Technologies
Coolant crossover, Seq. IIH Chrysler	OHT3H-302-1	OH Technologies
Adapter, coolant crossover, Seq. IIH Chrysler	OHT3H-303-1	OH Technologies
Jumper, harness segment, throttle control, Seq. IIH Chrysler ^B	OHT3H-004-1	OH Technologies
Harness, dyno, Seq. IIH Chrysler	OHT3H-005-1	OH Technologies
Exhaust turndown pipe drawings	IIH-ETB30-B	TMC
	IIH-ETB31-B	
	IIH-ETB32-B	
	IIH-ETB40-B	
	IIH-ETP42-B	
Air cleaner (optional)	04861729AB	Chrysler Dealer
Air resonator	04861731AB	Chrysler Dealer
Air hose (optional)	04861732AB	Chrysler Dealer
Throttle pedal (optional)	68043161AB	Chrysler Dealer
Electric starter (optional if air starter is used)	56029852AA	Chrysler Dealer
O ₂ sensor	56029050AA	Chrysler Dealer
Powertrain control module (PCM)	IMTS161000UC-PCM	International Machine Tool & Service (IMTS) ^C
Manual flywheel (2013 JK)	05184438AB	Chrysler Dealer
J-TEC blowby meter	VF563AA	J-Tec Associates, Inc.
Blowby canister	CCV6000	J-Tec Associates, Inc.
Dynamometer	Midwest 1014A	Dyne Systems
Driveshaft w/1410 U-Joints ^D		

^A Contact information for the suppliers is given in [Appendix X3](#).

^B Alternatively an accelerator pedal position (APP) sensor simulator circuit may be used as described in [Annex A11](#).

^C The sole source of supply known to the committee at this time is International Machine Tool & Service (IMTS) Co., 8460 Ronda Dr., Canton, MI 48187, USA, www.imtsind.com. If you are aware of alternative suppliers, please provide this information to ASTM International Headquarters. Your comments will receive careful consideration at a meeting of the responsible technical committee,¹ which you may attend.

^D Available through local suppliers.

TABLE 2 Engine-Build Parts List

Part Name	Quantity per Test	Part Number	Required Supplier ^A
Test engine, 2014 3.6L Pentastar RT	1	682524464AG (older version 05184464AH)	Mopar
Cylinder head – Left ^B (MS Seed/MC Core)	1	LH451AO-MSD	International Machine Tool & Service (IMTS)
Cylinder head – Right ^B (MS Seed/MC Core)	1	RH516AO-MS	International Machine Tool & Service (IMTS)
Piston, special test	6	OHT3H-070-1	OH Technologies, Inc.
Head gasket, right	1	05184456AH	Chrysler Dealer
Head gasket, left	1	05184455AI	Chrysler Dealer
Head bolts	8	06509564AA	Chrysler Dealer
Rod bolts	12	06509128AA	Chrysler Dealer
Exhaust flange gasket (cylinder head to exhaust)	2	68093232AA	Chrysler Dealer
Piston ring pack:	1		OH Technologies, Inc.
Ring, special test, UCR (0.025 mm gap, 96.040 mm bore)		3H96040-TOP	OH Technologies, Inc.
Ring, special test, LCR (0.035 mm gap, 96.040 mm bore)		3H96040-SECOND	OH Technologies, Inc.
Expander, Seq. IIH		3H96040-EXP	OH Technologies, Inc.
Rail, Seq. IIH		3H96040-RAIL	OH Technologies, Inc.
Pin, wrist, piston	6	OHT3H-071-1	OH Technologies, Inc.
Clip, piston, wrist pin	12	OHT3H-072-1	OH Technologies, Inc.
Phaser, intake (fixed at 100°, less rotor holes)	2	OHT3H-001-1	OH Technologies, Inc.
Phaser, exhaust (fixed at 112°, less rotor holes)	2	OHT3H-002-1	OH Technologies, Inc.
Oil pan ^C	1	OHT3H-304-2	OH Technologies, Inc.
Gasket, Oil Pan	1	OHT3H304-18	OH Technologies, Inc.
Seal, Valve Guide	24	5184168AB	Chrysler Dealer

^A Contact information for the suppliers is given in [Appendix X3](#).

^B All cylinder head purchases require a core exchange from each test engine.

^C Oil pan and plug may be used for multiple tests. Replace at the discretion of the laboratory either upon failure of pressure check or visual inspection.

6.3 *Drawings*—Obtain the equipment drawings referenced in [Table 1](#) from the TMC. Because the drawings may not be to scale or may not contain dimensions, when using them to fabricate special parts, do not use a dimensionless drawing as a pattern. Drawings supplied with dimensions are considered to be correct when the temperature of the equipment is 22 °C ± 3 °C, unless otherwise specified.

6.4 Test Engine:

6.4.1 The test engine is based on a Chrysler 2014 Pentastar V-6 engine^{9,10} with a displacement of 3.6 L, a compression ratio of 10.2:1, equipped with a production fuelinjection system and a special PCM for test-specific dynamometer operation. The

⁹ The sole source of supply of this equipment known to the committee at this time is FCA US LLC, P.O. Box 21-8004, Auburn Hills, MI 48321-8004, USA, Tel: 1-800 334 9200, fcanorthamerica.com.

TABLE 3 Recommended Control Parts for the FCM

Part Name	Supplier ^A	Part Number	Description
2-way coolant flow control valve	Badger Meter Inc.	9003GCW36SV3A29L36	2 in., 2-way air to close. Alternatively, a variable frequency drive (VFD) may be used instead of a 2-way valve to control pump speed and coolant flow. If necessary, a flow restrictor may be incorporated in place of the 2-way valve to achieve the required system pressure.
Heat exchanger	Kinetic Engineering Corp.		Tube and shell heat exchanger is an acceptable alternative.
Coriolis flow meter	Micro Motion Inc.	R200S418NCAMEZZZ Z meter, 1700113ABMEZZZ transmitter	Any other meter used shall meet or exceed a mass flow accuracy of $\pm 0.75\%$ and mass flow repeatability of $\pm 0.50\%$.
Fuel temperature heat exchange	Laboratory determined		
3-way coolant temperature control valve	Badger Meter Inc.	9003TCW36SV3AXXL36	2 in., globe cast 3-way wafer type, NPT 316/316L stainless steel body size 35, actuator, air to close, 3 spring for a 3 psi to 15 psi signal range. Alternatively, the use of the 3-way valve is not required if control of process water flow through the main engine coolant heat exchanger is maintained using a suitable 2-way valve (see Fig. 1).
Oil temperature control valve	Badger Meter Inc.	1002GCN36SVCSALN36	$\frac{1}{2}$ in. 2-way Research valve, A-trim
Drive shaft			Driveshaft w/1410 U-Joints
Coolant pump	Aurora	341A BF 1.5X2X9	

^A Contact information for the suppliers is given in Appendix X3.

variable valve timing is disabled by the use of fixed phasers in place of the production cam phasers. Complete test engines are available for purchase from Mopar.^{11,10} Each test will consist of a single, new complete test engine that will be assembled according to the Sequence IIIH Engine Assembly Manual.¹²

6.4.2 *Engine Parts*—Use the engine parts specified in the Sequence IIIH Engine Assembly Manual.¹²

6.4.3 Refer to Table 2 for a complete list of parts required to assemble the test engine.

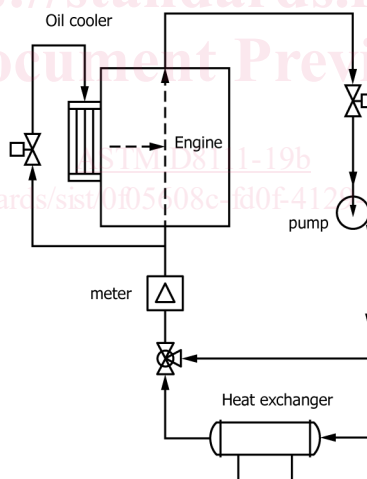

FIG. 2 Schematic of Flow System for Engine Coolant Using a Three-Way Control Valve to Maintain Coolant Flow

6.4.4 Use all engine parts as received from the supplier, central parts distributor (CPD), special parts supplier (SPS), or original equipment manufacturer unless modifications are specified in this test method or the Sequence IIIH Engine Assembly Manual.

6.4.5 Before disposing of any Sequence IIIH engine parts, destroy or otherwise render them useless for automotive engine applications.

6.5 *Engine Speed and Torque Control*—Use dynamometer speed and torque control systems that are capable of controlling the speed and torque requirements described in 10.4.

6.6 *Fluid Conditioning Module (FCM)*:

¹⁰ If you are aware of alternative suppliers, please provide this information to ASTM International Headquarters. Your comments will receive careful consideration at a meeting of the responsible technical committee,¹ which you may attend.

¹¹ Mopar is the registered trade mark of Chrysler Group Customer Care, P.O. Box 21-8004, Auburn Hills, MI 48321-8004, www.mopar.com.

¹² Available from the TMC at ftp://ftp.astmtmc.cmu.edu/docs/gas/sequenceiii/procedure_and_ils/IIIH.

6.6.1 *General*—The FCM controls the following test parameters: flow rate and temperature of the engine coolant, coolant flow rate through the engine oil cooler, and the test fuel supply. The components for this module are shown in Table 3.

6.6.2 *Engine Cooling System*—The FCM supplies coolant pressurized to 200 kPa, at a flow rate of 170 L/min and controls the coolant temperature at 115 °C at the engine coolant outlet. The system incorporates the following features: pump, Coriolis-type flow meter, flow-control and three-way-control valves (not required for alternative system, see Fig. 1), external cooling system, and low-point drains.

6.6.2.1 The system integrates with the test stand data acquisition and control computer for process control and maintains the specified engine coolant temperature and flow.

6.6.2.2 Schematics of the required flow system for the engine coolant are shown in Figs. 1 and 2.

6.6.2.3 A complete list of acceptable control system/engine interface components is shown in Table 1.

6.6.2.4 A list of parts for the engine coolant flow system control equipment is shown in Table 3.

6.6.2.5 Install a 3 kΩ resistor across the temperature sensor for the engine coolant to allow the PCM to receive an appropriate signal voltage to run the engine without the need to plug in the sensor wire on the wiring harness.

6.6.2.6 Flush the coolant system for the test stand with clean water at least once each reference period.

6.7 *Engine-Oil Cooling System*—The FCM controls engine-oil temperature by controlling the flow of engine coolant through the production oil cooler with the use of a 2-way, flow-control valve.

6.7.1 Do not use cuprous lines or fittings in the oil cooling system.

6.7.2 Do not use magnetic plugs in the oil system.

6.8 *Fuel System*—The FCM includes a pressure regulator to provide fuel at 420 kPa ± 20 kPa. Maintain fuel temperature at 30 °C throughout the test.

6.9 *Induction Air System*—Maintain the throttle body intake air at a moisture content of 11.4 g/kg ± 0.7 g/kg of dry air, a dry bulb temperature of 35 °C ± 2 °C, dew point of 16.1 °C and a static pressure of 0.050 kPa. Measure air-intake temperature and pressure at the air resonator (Chrysler P/N (part number) 04861731AB)^{9,10} in the center of flow 7 mm from the opening as shown in Fig. A2.1.

6.10 *Pressure-Transducer Locations:*

6.10.1 *Coolant Pressure*—Connect the transducer to the modified coolant crossover adapter P/N OHT3H303-1.^{13,10} Transducers with a gauge pressure range of 0 kPa to 300 kPa have been found to be suitable.

6.10.2 *Intake Air Pressure*—Install the transducer to the location shown in Fig. A2.1 and Fig. A2.5. Transducers with a gauge pressure range of -125 Pa to +125 Pa have been found to be suitable.

6.10.3 *Right- and Left-Exhaust Backpressure*—Insert probe into the exhaust turnaround pipes (see TMC drawing IIIH-ETP40-B¹⁴ position 4). Transducers with a gauge pressure range of 0 kPa to 70 kPa have been found to be suitable.

6.10.4 *Oil-Pump Pressure*—Connect the transducer to the location shown in Fig. A2.8. Transducers with a gauge pressure range of 0 kPa to 700 kPa have been found to be suitable.

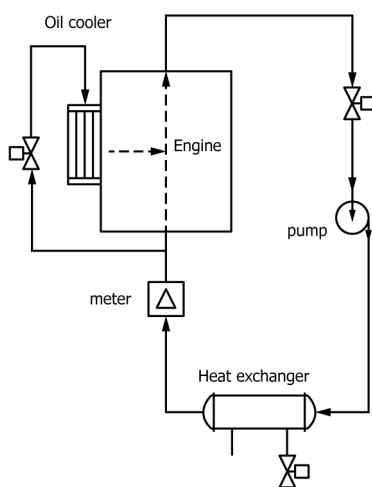

FIG. 1 Schematic of Flow System for Engine Coolant Flow Removing the Three-Way Valve and Controlling Coolant Temperature Using a Two-Way Valve at the Heat Exchanger

¹³ The sole source of supply of the apparatus known to the committee at this time is OH Technologies Inc., P.O. Box 5039, Mentor, OH 44061-5039, USA, www.ohtech.com.

¹⁴ Available from the TMC, 6555 Penn Avenue, Pittsburgh, PA 15206-4489. www.astmtmc.cmu.edu.

6.10.5 *Oil-Gallery Pressure*—Connect the transducer to the location shown in Fig. A2.6. Transducers with a gauge pressure range of 0 kPa to 700 kPa have been found to be suitable.

6.10.6 *Manifold Absolute Pressure*—Connect the transducer to the vacuum port on top of the throttle body and behind the throttle plate. Transducers with an absolute pressure range of 0 kPa to 100 kPa have been found to be suitable.

6.10.7 *Fuel Pressure*—Mount a fuel-distribution block to the front of the engine within 30 cm of the fuel-rail inlet as shown in Fig. A2.4. Russell Performance P/N RUS-650370^{15,10} (shown in Fig. A2.5) has been found to be suitable for fuel-pressure and temperature measurements. Transducers with a gauge pressure range of 0 kPa to 700 kPa have been found to be suitable.

6.10.8 *Crankcase Pressure*—Connect the transducer port tapped in the upper portion of the oil pan P/N OHT3H-304-2.^{13,10} Transducers with a gauge pressure range of –13 kPa to +13 kPa have been found to be suitable.

6.10.9 *Blowby Pressure*—Install a transducer in the blowby-ventilation system at the exit of the blowby canister. Maintain a minimum length of 20 times the pipe diameter between the thermocouple and the J-TEC meter (see A4.1). Transducers with a gauge pressure range of –13 kPa to +13 kPa have been found to be suitable.

6.11 *Thermocouple Locations:*

6.11.1 Locate the sensing tip of all thermocouples in the center of the stream of the medium being measured unless otherwise specified.

6.11.2 *Temperature of Oil Cooler*—This thermocouple is optional. If used, install in the rear of the oil cooler as shown in Fig. A2.6 and Fig. A2.7. Ensure the sensing tip is in the middle of the flow by fully inserting the sensing tip and reversing it out by 8 mm.

6.11.3 *Temperature of Coolant Exiting the Engine*—Install the thermocouple in the coolant crossover P/N OHT3H-302-1^{13,10} with the sensing tip centered in the coolant flow.

6.11.4 *Temperature of Intake Air*—Install the thermocouple through top of the air resonator, 7 cm from the edge where it joins the throttle body (see Fig. A2.3). Center the sensing tip in the center of the air flow.

6.11.5 *Fuel Temperature*—Install the thermocouple in a fuel-distribution block within 30 cm of the fuel- rail inlet (see 6.10.7). (**Warning**—Safety Hazard—Exercise care to reduce overhung masses at fuel-rail connections.)

6.11.6 *Oil-Pump Temperature*—Install the thermocouple in the oil-pump pressure/temperature assembly as shown in Fig. A2.8. Use a straight-thread plug and washer with a through hole no larger than 6 mm. A screw plug M24 × 1.5 (P/N HAR111.301.127.E) with an aluminum washer (P/N HAR 22 × 7 × 1.5 Al) has been found to be suitable.^{16,10}

6.11.7 *Oil-Sump Temperature*—Install the thermocouple in the oil-sump drain plug located on the underside of the oil pan P/N OHT3H-304-2,^{13,10} the sensing tip extending 10 mm beyond the end of the sump drain plug as shown in Fig. A2.9.

6.11.8 *Engine-Block Oil Temperature*—Refer to Section 4, Sheets 1 to 4, of the IIIH Engine Assembly Manual for the modification of the block required to accommodate the engine-block, oil-temperature thermocouple. To ensure the thermocouple is inserted to the correct depth, use the IMTS Thermocouple Setting Fixture P/N 151132-F002.^{17,10}

6.11.9 *Temperature of Coolant Into the Engine*—Install the thermocouple in the modified water pump P/N OHT3H-300-1^{13,10} with the sensing tip centered in the coolant flow.

6.11.10 *Right-Exhaust Temperature*—Install thermocouple in the exhaust turndown pipe (drawing IIIH-ETP30-B¹⁴) with the sensing tip centered in the exhaust flow

6.11.11 *Left-Exhaust Temperature*—Install thermocouple in the exhaust turndown pipe (drawing IIIH-ETP30-B¹⁴) with the sensing tip centered in the exhaust flow.

6.11.12 *Blowby-Gas Temperature*—Install the thermocouple in the blowby ventilation system at the exit of the blowby canister. Maintain a minimum length of 20-pipe diameters between the thermocouple and the meter (see A4.1).

6.12 *Crankcase Ventilation:*

6.12.1 Ventilate blowby gasses ventilated from the test cell through a scavenger fan. Do not allow the fan to create a vacuum on the crankcase. Do not insulate any components in the blowby system. An Air Ecology Evacuation System^{18,10} has been found to be suitable. The crankcase ventilation configuration is shown in Annex A3.

7. Reagents and Materials

7.1 *Test Fuel*—Use only Sequence III HF-003 EEE unleaded fuel.^{19,10} (**Warning**—Flammable. Health hazard.) The required fuel properties and tolerances are shown in Table A12.1.

7.1.1 Make certain that all tanks used for transportation and storage are clean before filling with test fuel.

7.1.2 Ensure that at least 3450 L of test fuel is available.

¹⁵ Available from Summit Racing Equipment, P.O. Box 909, Akron, OH 44309–0909, tel 1-800-230-3039, www.summitracing.com.

¹⁶ Patrick Motor Sports, 4025 E. Madison St., Phoenix, AZ, 85034, USA, www.patrickmotorsports.com.

¹⁷ The sole source of supply known to the committee at this time is International Machine Tool & Service (IMTS) Co., 8460 Ronda Dr., Canton, MI 48187, USA, www.imtsind.com.

¹⁸ Purchase from AER Control Systems, 90 River St., New Haven , CT 06513, www.aercontrolsystems.com.

¹⁹ The sole source of supply of this fuel known to the committee at this time is Haltermann Products, 1201 Sheldon Rd., P.O. Box 429, Channelview, TX 77530–0429, USA.

7.2 Engine Coolant:

7.2.1 Use a mixture of ShellZone DEX-COOL antifreeze/coolant^{20,21} and de-ionized water with a volume fraction of water of 50 %. (**Warning**—Health hazard—see appropriate MSDS).

7.2.1.1 Use new coolant for every test.

7.2.1.2 *Coolant Preparation*—Use a container of a size adequate to hold the entire coolant blend required for the system.

7.2.1.3 Measure equal parts of coolant and deionized water. Verify with a refractometer that the volume fraction of coolant in the mixture is between 48 % and 52 % coolant prior to each use.

7.2.2 Alternatively, a 50/50 premix²¹ may be purchased for use if desired.

7.3 *Degreasing Solvent*—Use only mineral spirits meeting the specifications for volume fraction of aromatics 0 % to 2 %, flash point 61 °C minimum, and color not darker than +25 on Saybolt Scale or 25 on Pt-Co Scale from Specification **D235** for the Type II, Class C mineral spirits. (**Warning**—Combustible. Health hazard.)

7.4 *Sealing and Anti-Seize Compounds*—Mopar ThreeBond Engine RTV,²² P/N 68082860AA²³ Room Temperature Vulcanization Silicone (RTV silicone).²³

7.4.1 Loctite²⁴ 545 Thread Sealant, Anaerobic.^{25,10}

7.4.2 Loctite 567 Thread Sealant, Low strength, Anaerobic.^{25,10}

7.4.3 Loctite 648 Retaining Compound, Anaerobic.^{25,10}

7.4.4 Loctite Gasket Sealant 2 (Permatex #2).^{25,10}

7.4.5 Polytetrafluoroethylene (PTFE) Tape.

7.5 Engine Cleaning:

7.5.1 Use Ultrasonic-7²⁶ soap and Ultrasonic-B degreaser²⁶ in ultrasonic parts washers to clean engine block, cylinder heads and fixed phasers. Cleaning solution shall be at a temperature of 65 °C ± 5 °C.

7.5.2 Alternatively, use an aquas cleaning solution of 50/50 Brulin US Solution^{27,10} products 815 GD and 815 QR-DF or 815 QR-NF to achieve a volume fraction of 12.5 % of the total cleaning solution, provided that the laboratory has conducted a successful reference oil test using this solution.

7.6 Engine build up oil, EF-411.^{28,10}

8. Test Oil Requirements

8.1 *Selection*—The supplier of the test oil sample shall determine that the test oil sample is representative of the lubricant formulation to be evaluated and that it is not contaminated.

8.2 *Quantity*—The supplier shall provide a test oil sample of at least 7.5 L.

8.3 *Storage Prior to Test*—The test laboratory shall store the test oil sample in a covered building to prevent contamination by rainwater (see also **A5.3**).

9. Preparation of Apparatus

9.1 Pre-Test Engine Disassembly and Cleaning:

9.1.1 Disassemble the new engine according to the guidelines in Section 3 of the New Engine Disassembly of the Sequence IIIH Engine Assembly Manual.¹²

9.2 Cylinder-head Disassembly:

9.2.1 Disassemble the production cylinder heads according to information supplied in Sections 2 and 3 of the Sequence IIIH Engine Assembly Manual.¹²

9.2.2 Send the disassembled, production cylinder heads (cylinder head cores) to the SPS for replacement of intake valve-seats.^{17,10} See Section 2 Sheet 2 of the Sequence IIIH Engine Assembly Manual for details.

9.2.3 Clean the test cylinder heads as outlined in Sections 5 and 6 of the Sequence IIIH Engine Assembly Manual.

9.2.4 Assemble the modified cylinder heads P/N LH451AO-MS and RH516AO-MSD^{17,10} from new engine cylinder heads. See Section 6 of the Sequence IIIH Engine Assembly Manual.

9.2.5 Use new valve-stem seals for each test.

²⁰ ShellZone is a registered trademark of Shell Trademark Management BV.

²¹ Available from retailers, autoparts stores, or any Mopar dealer.

²² ThreeBond is a registered trademark of ThreeBond International, Inc.

²³ Available from any Mopar dealer.

²⁴ Loctite is a registered trademark of Henkel Corporation.

²⁵ Available from Henkel Corporation, One Henkel Way, Rocky Hill, CT 06067, USA. www.henkelna.com.

²⁶ Available from TEI, 12718 Cimarron Path, San Antonio, TX 78249, USA, Tel: (210) 690-1958.

²⁷ The sole source of supply of this product known to the committee at this time is Brulin & Company, 2920 Dr. Andrew J. Brown Av, Indianapolis, IN 46205, 317.923.3211. csr@brulin.com.

²⁸ The sole source of supply of this product known to the committee at this time is Exxon-Mobil Oil Corp., Attention Illinois Order Board, P.O. Box 66940, AMF O'Hare, IL 60666, USA.