

PUBLICLY AVAILABLE SPECIFICATION

PRE-STANDARD

Fibre optic interconnecting devices and passive components – Fibre optic connector optical interfaces –
Part 3-30: End face geometry – Angled PC end face PPS rectangular ferrule multimode A1b fibres

[IEC PAS 63267-3-30:2021](https://standards.iteh.ai/catalog/standards/sist/700cafa5-376e-4521-b70c-f03770b047da/iec-pas-63267-3-30-2021)

<https://standards.iteh.ai/catalog/standards/sist/700cafa5-376e-4521-b70c-f03770b047da/iec-pas-63267-3-30-2021>



THIS PUBLICATION IS COPYRIGHT PROTECTED
Copyright © 2021 IEC, Geneva, Switzerland

All rights reserved. Unless otherwise specified, no part of this publication may be reproduced or utilized in any form or by any means, electronic or mechanical, including photocopying and microfilm, without permission in writing from either IEC or IEC's member National Committee in the country of the requester. If you have any questions about IEC copyright or have an enquiry about obtaining additional rights to this publication, please contact the address below or your local IEC member National Committee for further information.

IEC Central Office
3, rue de Varembe
CH-1211 Geneva 20
Switzerland

Tel.: +41 22 919 02 11
info@iec.ch
www.iec.ch

About the IEC

The International Electrotechnical Commission (IEC) is the leading global organization that prepares and publishes International Standards for all electrical, electronic and related technologies.

About IEC publications

The technical content of IEC publications is kept under constant review by the IEC. Please make sure that you have the latest edition, a corrigendum or an amendment might have been published.

IEC publications search - webstore.iec.ch/advsearchform

The advanced search enables to find IEC publications by a variety of criteria (reference number, text, technical committee, ...). It also gives information on projects, replaced and withdrawn publications.

IEC online collection - oc.iec.ch

Discover our powerful search engine and read freely all the publications previews. With a subscription you will always have access to up to date content tailored to your needs.

IEC Just Published - webstore.iec.ch/justpublished

Stay up to date on all new IEC publications. Just Published details all new publications released. Available online and once a month by email.

Electropedia - www.electropedia.org

The world's leading online dictionary on electrotechnology, containing more than 22 000 terminological entries in English and French, with equivalent terms in 18 additional languages. Also known as the International Electrotechnical Vocabulary (IEV) online.

IEC Customer Service Centre - webstore.iec.ch/csc

If you wish to give us your feedback on this publication or need further assistance, please contact the Customer Service Centre: sales@iec.ch.

[IEC PAS 63267-3-30:2021](https://standards.iteh.ai/catalog/standards/sist/700cfa5-376e-4521-b70c-f03770b047da/iec-pas-63267-3-30-2021)

[https://standards.iteh.ai/catalog/standards/sist/700cfa5-376e-4521-b70c-](https://standards.iteh.ai/catalog/standards/sist/700cfa5-376e-4521-b70c-f03770b047da/iec-pas-63267-3-30-2021)

[f03770b047da/iec-pas-63267-3-30-2021](https://standards.iteh.ai/catalog/standards/sist/700cfa5-376e-4521-b70c-f03770b047da/iec-pas-63267-3-30-2021)

PUBLICLY AVAILABLE SPECIFICATION

PRE-STANDARD

Fibre optic interconnecting devices and passive components – Fibre optic connector optical interfaces – Part 3-30: End face geometry – Angled PC end face PPS rectangular ferrule multimode A1b fibres

[IEC PAS 63267-3-30:2021](https://standards.iteh.ai/catalog/standards/sist/700cfa5-376e-4521-b70c-f03770b047da/iec-pas-63267-3-30-2021)

<https://standards.iteh.ai/catalog/standards/sist/700cfa5-376e-4521-b70c-f03770b047da/iec-pas-63267-3-30-2021>

INTERNATIONAL
ELECTROTECHNICAL
COMMISSION

ICS 33.180.20

ISBN 978-2-8322-9837-4

Warning! Make sure that you obtained this publication from an authorized distributor.

CONTENTS

FOREWORD.....	3
1 Scope.....	5
2 Normative references	5
3 Terms and definitions	5
4 Description	5
5 Interface parameters	6
Annex A (normative) Minus coplanarity	10
Bibliography.....	11
Figure 1 – Fibre numbering conventions	7
Figure 2 – Interface dimensions related to longitudinal offset.....	7
Figure A.1 – Illustration of fibre line and minus coplanarity parameters	10
Table 1 – Optical interface variant information	6
Table 2 – Physical contact end face geometry dimensions having < 50 % fibres with core dip for optical interface variant 1116	8
Table 3 – Physical contact end face geometry dimensions having ≥ 50 % fibres with core dip for optical interface variant 1116	9

(standards.iteh.ai)

[IEC PAS 63267-3-30:2021](https://standards.iteh.ai/catalog/standards/sist/700cfa5-376e-4521-b70c-f03770b047da/iec-pas-63267-3-30-2021)

<https://standards.iteh.ai/catalog/standards/sist/700cfa5-376e-4521-b70c-f03770b047da/iec-pas-63267-3-30-2021>

INTERNATIONAL ELECTROTECHNICAL COMMISSION

**FIBRE OPTIC INTERCONNECTING
DEVICES AND PASSIVE COMPONENTS –
FIBRE OPTIC CONNECTOR OPTICAL INTERFACES –**

**Part 3-30: End face geometry – Angled PC end
face PPS rectangular ferrule multimode A1b fibres**

FOREWORD

- 1) The International Electrotechnical Commission (IEC) is a worldwide organization for standardization comprising all national electrotechnical committees (IEC National Committees). The object of IEC is to promote international co-operation on all questions concerning standardization in the electrical and electronic fields. To this end and in addition to other activities, IEC publishes International Standards, Technical Specifications, Technical Reports, Publicly Available Specifications (PAS) and Guides (hereafter referred to as "IEC Publication(s)"). Their preparation is entrusted to technical committees; any IEC National Committee interested in the subject dealt with may participate in this preparatory work. International, governmental and non-governmental organizations liaising with the IEC also participate in this preparation. IEC collaborates closely with the International Organization for Standardization (ISO) in accordance with conditions determined by agreement between the two organizations.
- 2) The formal decisions or agreements of IEC on technical matters express, as nearly as possible, an international consensus of opinion on the relevant subjects since each technical committee has representation from all interested IEC National Committees.
- 3) IEC Publications have the form of recommendations for international use and are accepted by IEC National Committees in that sense. While all reasonable efforts are made to ensure that the technical content of IEC Publications is accurate, IEC cannot be held responsible for the way in which they are used or for any misinterpretation by any end user.
- 4) In order to promote international uniformity, IEC National Committees undertake to apply IEC Publications transparently to the maximum extent possible in their national and regional publications. Any divergence between any IEC Publication and the corresponding national or regional publication shall be clearly indicated in the latter.
- 5) IEC itself does not provide any attestation of conformity. Independent certification bodies provide conformity assessment services and, in some areas, access to IEC marks of conformity. IEC is not responsible for any services carried out by independent certification bodies.
- 6) All users should ensure that they have the latest edition of this publication.
- 7) No liability shall attach to IEC or its directors, employees, servants or agents including individual experts and members of its technical committees and IEC National Committees for any personal injury, property damage or other damage of any nature whatsoever, whether direct or indirect, or for costs (including legal fees) and expenses arising out of the publication, use of, or reliance upon, this IEC Publication or any other IEC Publications.
- 8) Attention is drawn to the Normative references cited in this publication. Use of the referenced publications is indispensable for the correct application of this publication.
- 9) Attention is drawn to the possibility that some of the elements of this IEC Publication may be the subject of patent rights. IEC shall not be held responsible for identifying any or all such patent rights.

A PAS is an intermediate specification made available to the public and needing a lower level of consensus than an International Standard to be approved by vote (simple majority).

IEC PAS 63267-3-30 has been prepared by subcommittee 86B: Fibre optic interconnecting devices and passive components, of IEC technical committee 86: Fibre optics.

The text of this PAS is based on the following document:

This PAS was approved for publication by the P-members of the committee concerned as indicated in the following document

Draft PAS	Report on voting
86B/4432/DPAS	86B/4457/RVDPAS

Following publication of this PAS, which is a pre-standard publication, the technical committee or subcommittee concerned may transform it into an International Standard.

This PAS shall remain valid for an initial maximum period of 2 years starting from the publication date. The validity may be extended for a single period up to a maximum of 2 years, at the end of which it shall be published as another type of normative document, or shall be withdrawn.

iTeh STANDARD PREVIEW (standards.iteh.ai)

[IEC PAS 63267-3-30:2021](https://standards.iteh.ai/catalog/standards/sist/700cfa5-376e-4521-b70c-f03770b047da/iec-pas-63267-3-30-2021)

<https://standards.iteh.ai/catalog/standards/sist/700cfa5-376e-4521-b70c-f03770b047da/iec-pas-63267-3-30-2021>

FIBRE OPTIC INTERCONNECTING DEVICES AND PASSIVE COMPONENTS – FIBRE OPTIC CONNECTOR OPTICAL INTERFACES –

Part 3-30: End face geometry – Angled PC end face PPS rectangular ferrule multimode A1b fibres

1 Scope

This part of IEC 63267 defines certain dimensional limits of an 16F MM angled PC rectangular polyphenylene sulphide (PPS) ferrule optical interface in order to meet specific longitudinal offset requirements for fibre-to-fibre interconnection. Ferrules made from the material specified in this document are suitable for use in categories C, OP, OP+, I and E as defined in IEC 61753-1.

Ferrule interface dimensions and features are contained in IEC 61754 (all parts), which deals with fibre optic connector interfaces.

2 Normative references

The following documents are referred to in the text in such a way that some or all of their content constitutes requirements of this document. For dated references, only the edition cited applies. For undated references, the latest edition of the referenced document (including any amendments) applies.

[IEC PAS 63267-3-30:2021](https://standards.iteh.ai/catalog/standards/sist/700cfa5-376e-4521-b70c-03770b047d4/iec-pas-63267-3-30-2021)

[https://standards.iteh.ai/catalog/standards/sist/700cfa5-376e-4521-b70c-](https://standards.iteh.ai/catalog/standards/sist/700cfa5-376e-4521-b70c-03770b047d4/iec-pas-63267-3-30-2021)

IEC 61300-3-30, *Fibre optic interconnecting devices and passive components – Basic test and measurement procedures – Part 3-30: Examinations and measurements – Endface geometry of rectangular ferrule*

3 Terms and definitions

No terms and definitions are listed in this document.

ISO and IEC maintain terminological databases for use in standardization at the following addresses:

- IEC Electropedia: available at <http://www.electropedia.org/>
- ISO Online browsing platform: available at <http://www.iso.org/obp>

4 Description

The performance of a multimode angled PC rectangular ferrule optical interface is determined by the accuracy with which the optical datum targets of two mating ferrules are aligned with each other. There are three conditions affecting the alignment of the optical datum targets: lateral offset, angular offset, and longitudinal offset.

Parameters influencing the lateral and angular offset of the optical fibre axes include the following:

- fibre hole deviation from designated location;
- fibre cladding diameter relative to fibre hole clearance;

- fibre hole angular misalignment;
- fibre core concentricity relative to the cladding diameter;
- alignment pin diameter relative to the guide hole clearance.

Parameters influencing the longitudinal offset of the optical fibre axes include the following:

- fibre protrusion;
- fibre array minus coplanarity;
- adjacent fibre height differential;
- end face angle in the x-axis;
- end face angle in the y-axis;
- end face radius in the x-axis;
- end face radius in the y-axis;
- fibre tip spherical radii;
- axial force on ferrule end face;
- ferrule and fibre material constants;
- frictional force of alignment pins in ferrule guide holes;
- core dip.

5 Interface parameters

ITeH STANDARD PREVIEW
(standards.iteh.ai)

This document defines the dimensional limits of angled PC rectangular ferrules with a single row of 16 fibres. The fibre centres are spaced with a nominal alignment pitch of 0,25 mm. Interface variant, which identifies nominal ferrule cross-section, is given in Table 1. The fibre numbering conventions are illustrated in Figure 1.

Table 1 – Optical interface variant information

Variant number ^{b, c}	Nominal ferrule cross section ^a (mm × mm)	Number of fibres
1116	2,45 × 6,4	16

^a Refer to the applicable IEC 61754 series fibre optic connector interface standard for dimensional requirements.

^b The four digit variant code describes a combination of material type, nominal ferrule cross-section, and number of fibres. The first digit defines 1 for PPS ferrule materials; the second digit represents 2,45 mm × 4,4 mm with 0 and 2,45 mm × 6,4 mm with 1; and the last two digits designates the number of fibres.

^c All ferrule materials for rectangular type ferrules are intended to be intermateable, in the lowest specified performance category as described within IEC 61755-1, provided that the last three digits of the variant number are the same.

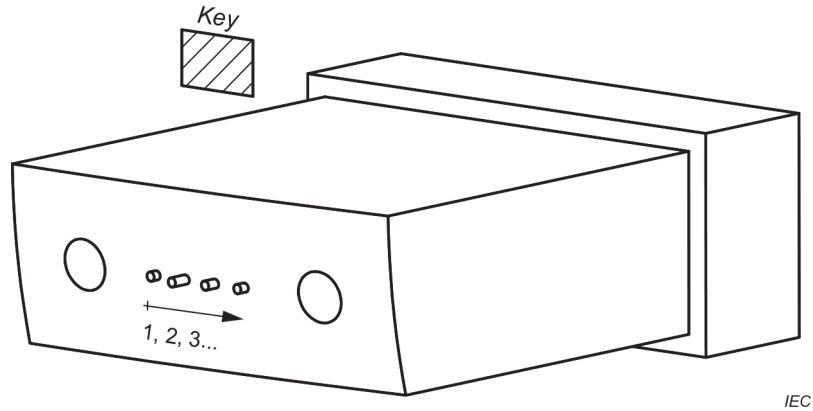

Figure 1 – Fibre numbering conventions

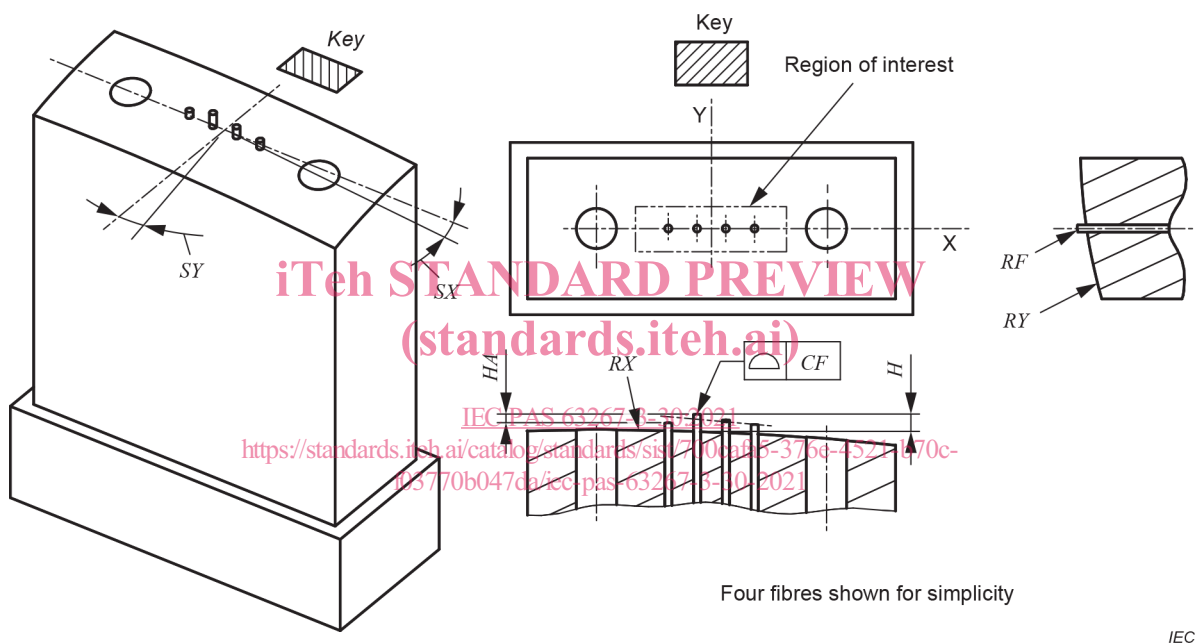

Figure 2 – Interface dimensions related to longitudinal offset

The optical interface coordinate system is established with an x-axis, which passes through the guide hole centres, a perpendicular y-axis that passes through the midpoint of the line connecting the guide hole centres, and an orthogonal z-axis pointing away from the ferrule. All parameters are illustrated as positive values with respect to the defined coordinate system. End face geometry limits associated with longitudinal offset when < 50 % of the fibres have core dip are specified in Table 2. End face geometry limits associated with longitudinal offset when > 50 % of the fibres have core dip are specified in Table 3. In this case, the maximum minus coplanarity is reduced.

Table 2 – Physical contact end face geometry dimensions having < 50 % fibres with core dip for optical interface variant 1116

Ref.	Parameter values		Units	Remarks
	Minimum	Maximum		
<i>CF</i>	-	0,25	µm	Minus side coplanarity ^a
<i>SX</i>	-0,15	0,15	°	Ferrule surface x-angle ^b
<i>SY</i>	7,8	8,2	°	Ferrule surface y-angle ^c
<i>H</i>	1	3,5	µm	Fibre height ^d
<i>HA</i>	0	0,3	µm	Adjacent fibre height differential
<i>RF</i>	1	-	mm	Fibre tip spherical radius ^e
<i>RX</i>	2 000 (convex) -10 000 (concave)	-	mm	Ferrule surface x-radius
<i>RY</i>	5	-	mm	Ferrule surface y-radius
<i>CD</i>		120	nm	Core dip

The end face geometry shall be measured in accordance with IEC 61300-3-30.

The values in Table 2 shall be specified in the central surface region surrounding fibres of 2,900 mm wide and 0,675 mm high. Furthermore, the outside surface region is lower than the central surface region of interest.

NOTE 1 Refer to Figure 2 for dimensional references.

NOTE 2 The values in Table 2 apply for polyphenylene sulphide (PPS) ferrules with a Young's modulus of 15 GPa to 20 GPa. Ferrule compression force: 20 N nominal.

^a Refer to Annex A for a description of minus side coplanarity.

^b X-angle represents the slope of the ferrule surface as defined by a bi-parabolic fit in accordance with IEC 61300-3-30. <https://standards.iteh.ai/catalog/standards/sist/700cfa5-376e-4521-b70c-007676767676/iec-63267-3-30-2021>

^c Y-angle represents the slope of the ferrule surface as defined by a bi-parabolic fit in accordance with IEC 61300-3-30. <https://standards.iteh.ai/catalog/standards/sist/700cfa5-376e-4521-b70c-007676767676/iec-63267-3-30-2021>

^d A positive value indicates a fibre protrusion.

^e Fibre tip spherical radii fitting region is defined within IEC 61300-3-30.