



Designation: D5389 – 93 (Reapproved 2019)

Standard Test Method for Open-Channel Flow Measurement by Acoustic Velocity Meter Systems¹

This standard is issued under the fixed designation D5389; the number immediately following the designation indicates the year of original adoption or, in the case of revision, the year of last revision. A number in parentheses indicates the year of last reapproval. A superscript epsilon (ϵ) indicates an editorial change since the last revision or reapproval.

1. Scope

1.1 This test method covers the measurement of flow rate of water in open channels, streams, and closed conduits with a free water surface.

1.2 The test method covers the use of acoustic transmissions to measure the average water velocity along a line between one or more opposing sets of transducers—by the time difference or frequency difference techniques.

1.3 The values stated in SI units are to be regarded as the standard.

1.4 *This standard does not purport to address all of the safety concerns, if any, associated with its use. It is the responsibility of the user of this standard to establish appropriate safety, health, and environmental practices and determine the applicability of regulatory limitations prior to use.* Specific precautionary statements are given in Section 6.

1.5 *This international standard was developed in accordance with internationally recognized principles on standardization established in the Decision on Principles for the Development of International Standards, Guides and Recommendations issued by the World Trade Organization Technical Barriers to Trade (TBT) Committee.*

2. Referenced Documents

2.1 *ASTM Standards:*²

[D1129 Terminology Relating to Water](#)

[D2777 Practice for Determination of Precision and Bias of Applicable Test Methods of Committee D19 on Water](#)

[D3850 Test Method for Rapid Thermal Degradation of Solid Electrical Insulating Materials By Thermogravimetric Method \(TGA\)](#)

¹ This test method is under the jurisdiction of ASTM Committee D19 on Water and is the direct responsibility of Subcommittee D19.07 on Sediments, Geomorphology, and Open-Channel Flow.

Current edition approved Nov. 1, 2019. Published January 2020. Originally approved in 1993. Last previous edition approved in 2013 as D5389 – 93 (2013). DOI: 10.1520/D5389-93R19.

² For referenced ASTM standards, visit the ASTM website, www.astm.org, or contact ASTM Customer Service at service@astm.org. For *Annual Book of ASTM Standards* volume information, refer to the standard's Document Summary page on the ASTM website.

[D3858 Test Method for Open-Channel Flow Measurement of Water by Velocity-Area Method](#)

2.2 *ISO Standard:*³

[ISO 6416 Liquid Flow Measurements in Open Channels—Measurement of Discharge by the Ultrasonic \(Acoustic\) Method](#)

3. Terminology

3.1 *Definitions:*

3.1.1 For definitions of terms used in this standard, refer to Terminology [D1129](#).

3.2 *Definitions of Terms Specific to This Standard:*

3.2.1 *acoustic path, n*—the straight line between the centers of two acoustic transducers.

3.2.2 *acoustic path length, n*—the face-to-face distance between transducers on an acoustic path.

3.2.3 *acoustic transducer, n*—a device that is used to generate acoustic signals when driven by an electric voltage, and conversely, a device that is used to generate an electric voltage when excited by an acoustic signal.

3.2.4 *acoustic travel time, n*—the time required for an acoustic signal to propagate along an acoustic path, either upstream or downstream.

3.2.5 *discharge, n*—the rate of flow expressed in units of volume of water per unit of time. The discharge includes any sediment or other materials that may be dissolved or mixed with it.

3.2.6 *line velocity, n*—the downstream component of water velocity averaged over an acoustic path.

3.2.7 *measurement plane, n*—the plane formed by two or more parallel acoustic paths of different elevations.

3.2.8 *path velocity, n*—the water velocity averaged over the acoustic path.

3.2.9 *stage, n*—the height of a water surface above an established (or arbitrary) datum plane; also gage height.

³ Available from American National Standards Institute (ANSI), 25 W. 43rd St., 4th Floor, New York, NY 10036, <http://www.ansi.org>.

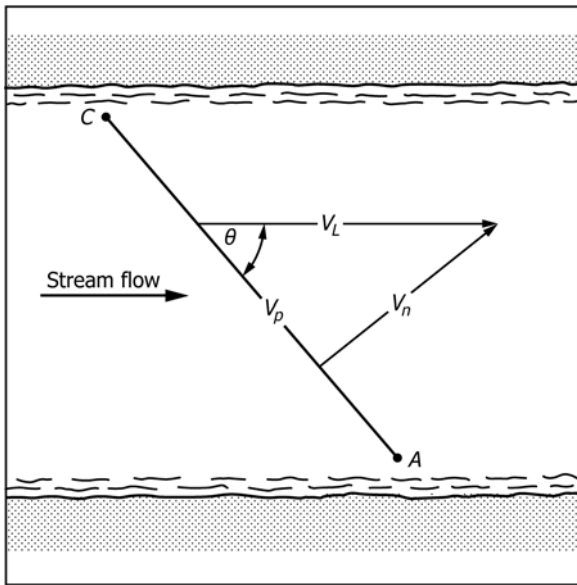

FIG. 1 Velocity Component Used in Developing Travel-Time Equations

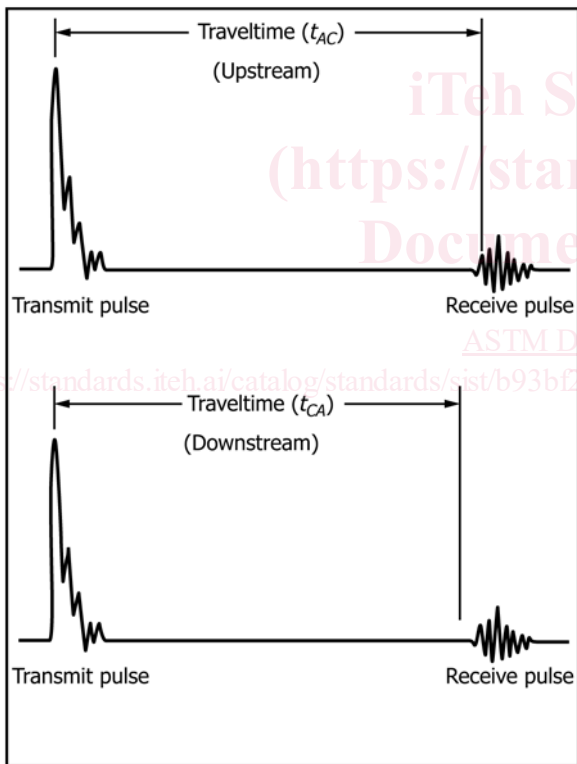

FIG. 2 Voltage Representation of Transmit and Receive Pulses at Upstream and Downstream Transducers

3.2.10 *velocity sampling, n*—means of obtaining line velocities in a measurement plane that are suitable for determining flow rate by a velocity-area integration.

4. Summary of Test Method

4.1 Acoustic velocity meter (AVM) systems, also known as ultrasonic velocity meter (UVM) systems, operate on the

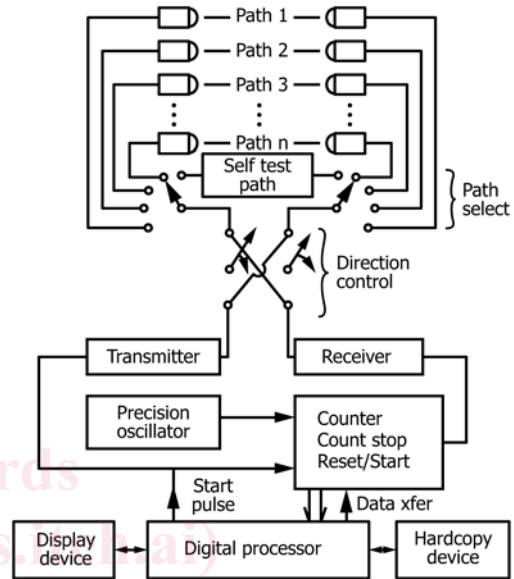
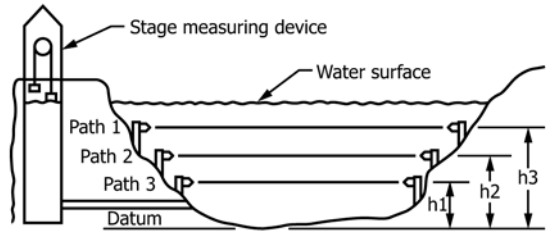

FIG. 3 Example of Acoustic Velocity/Flow Measuring System

principle that the point-to-point upstream traveltime of an acoustic pulse is longer than the downstream traveltime and that this difference in travel time can be accurately measured by electronic devices.

4.2 Most commercial AVM systems that measure stream-flow use the time-of-travel method to determine velocity along an acoustic path set diagonal to the flow. This test method⁴ describes the general formula for determining line velocity defined as (Fig. 1 and Fig. 2):

$$V_L = \frac{B}{2 \cos \theta} \left[\frac{1}{t_{CA}} - \frac{1}{t_{AC}} \right] \quad (1)$$

where:

V_L = line velocity, or the average water velocity at the depth of the acoustic path,

θ = angle of departure between streamflow and the acoustic path,

t_{AC} = traveltime from A to C (upstream),

t_{CA} = traveltime from C to A (downstream), and

B = length of the acoustic path from A to C.

⁴Laenen, A., and Smith, W., "Acoustic Systems for the Measurement of Streamflow," U.S. Geological Survey Water Supply Paper 2213, 1983.

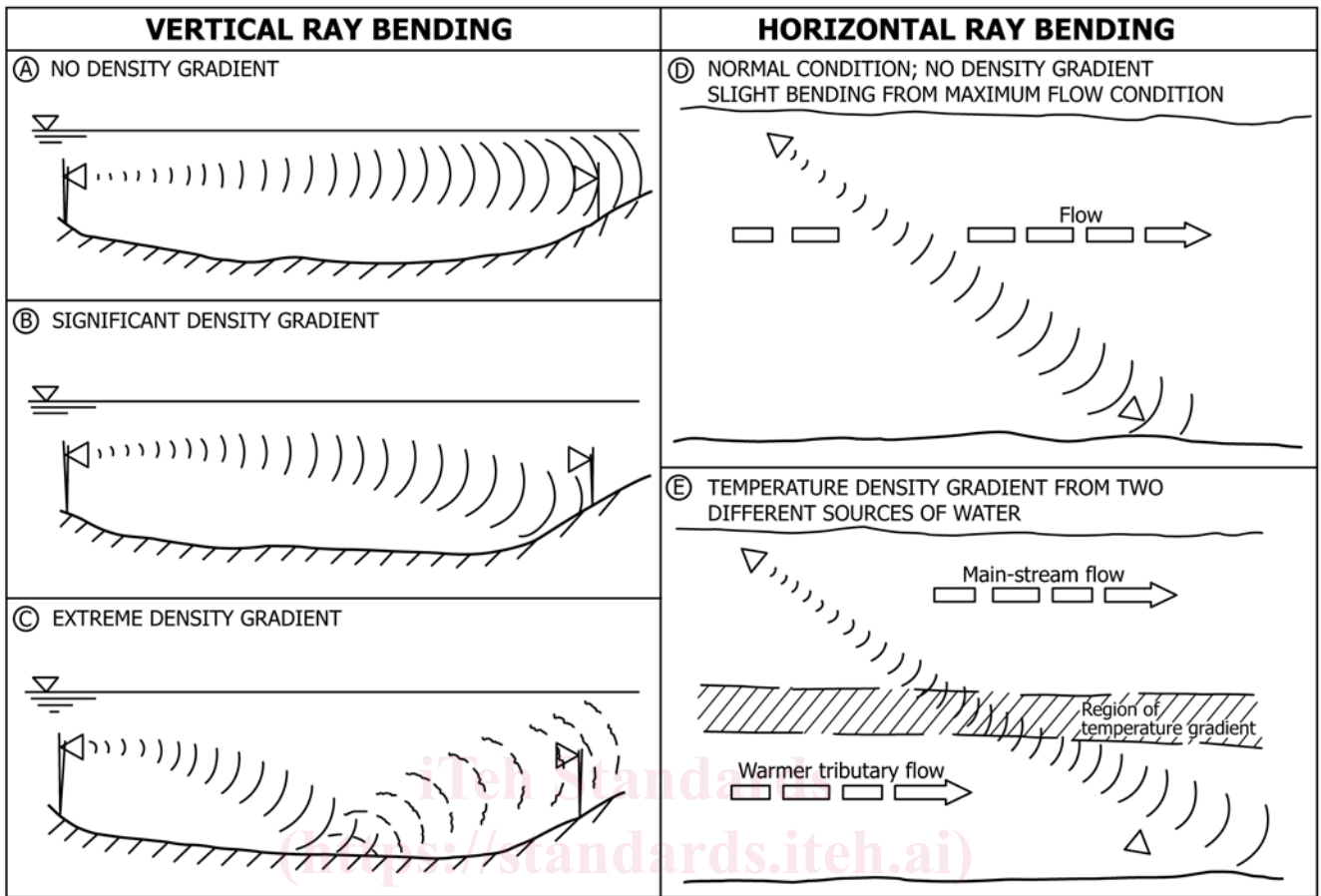

FIG. 4 Signal Bending Caused by Different Density Gradients⁴

4.3 The discharge measurement or volume flow rate determination made with an AVM relies on a calibrated or theoretical relation between the line velocity as measured by the AVM and mean velocity in the flow segment being measured. Taking more line velocity measurements across the channel at different elevations in the acoustic plane and performing a numerical integration or weighted summation of the measured velocities and areas of flow can be used to better define the volume flow rate. The spacing between acoustic paths, the spacing between the top path and the liquid surface, and the spacing between the lowest path and the bottom are determined on the basis of stream cross-section geometry or estimates of the vertical-velocity distribution and by the required measurement accuracy. In addition to several line velocity measurements, it is necessary to provide water level (stage) and cross-sectional area information for calculation of the volume flow rate (see Fig. 3).

5. Significance and Use

5.1 This test method is used where high accuracy of velocity or continuous discharge measurement over a long period of time is required and other test methods of measurement are not feasible due to low velocities in the channel, variable stage-discharge relations, complex stage-discharge relations, or the presence of marine traffic. It has the additional advantages of

requiring no moving parts, introducing no head loss, and providing virtually instantaneous readings (1 to 100 readings per second).

5.2 The test method may require a relatively large amount of site work and survey effort and is therefore most suitable for permanent or semi-permanent installations.

6. Interferences

6.1 *Refraction*—The path taken by an acoustic signal will be bent if the medium through which it is propagating varies significantly in temperature or density. This condition, known as ray bending, is most severe in slow moving streams with poor vertical mixing or tidal (estuaries) with variable salinity. In extreme conditions the signal may be lost. Examples of ray bending are shown in Fig. 4. Beam deflection for various temperatures and specific conductivities are shown in Fig. 5 and Fig. 6.

6.2 *Reflection*—Acoustic signals may be reflected by the water surface or streambed. Reflected signals can interfere with, or cancel, signals propagated along the measurement plane. When thermal or density gradients are present, the placement of transducers with respect to boundaries is most critical. This condition is most critical in shallow streams. A general rule of thumb to prevent reflection interference is to

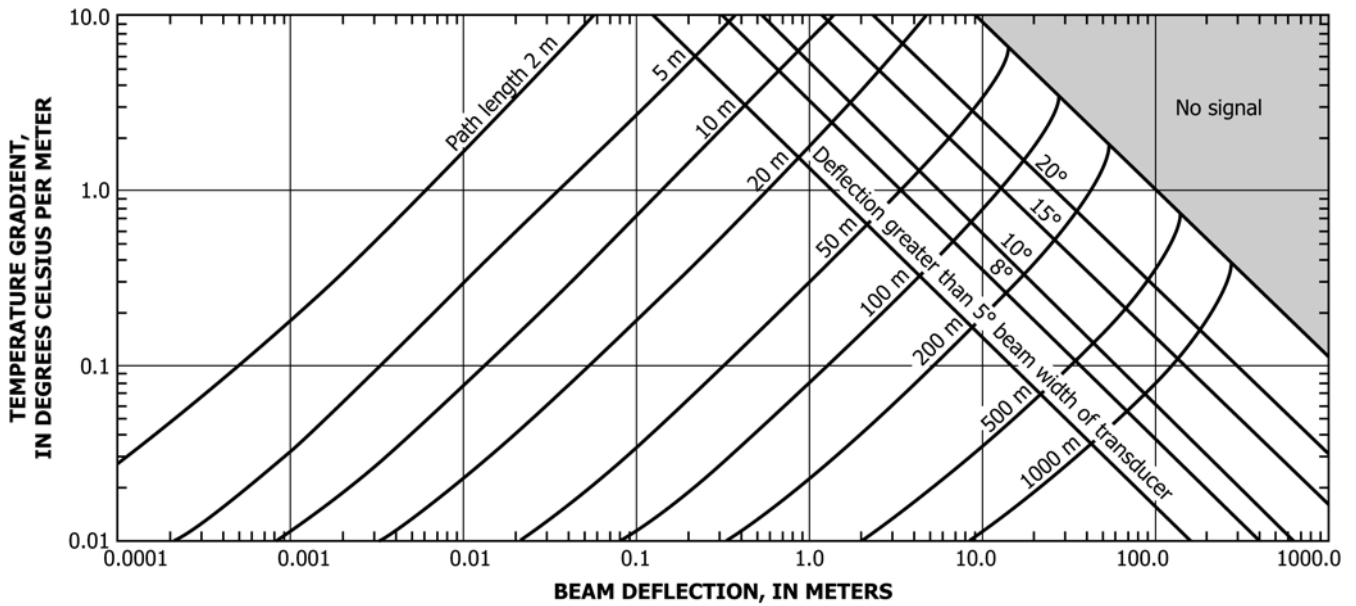

NOTE 1—Transducer directivity or beam width determined at the 30-dB level of the transmitted signal pattern. The signal is propagated beyond the beam width but at a weak level. In the shaded area the detection is so great that signals cannot be received directly for any transducer beam width.

FIG. 5 Beam Deflection From Linear Temperature Gradients for Different Path Lengths

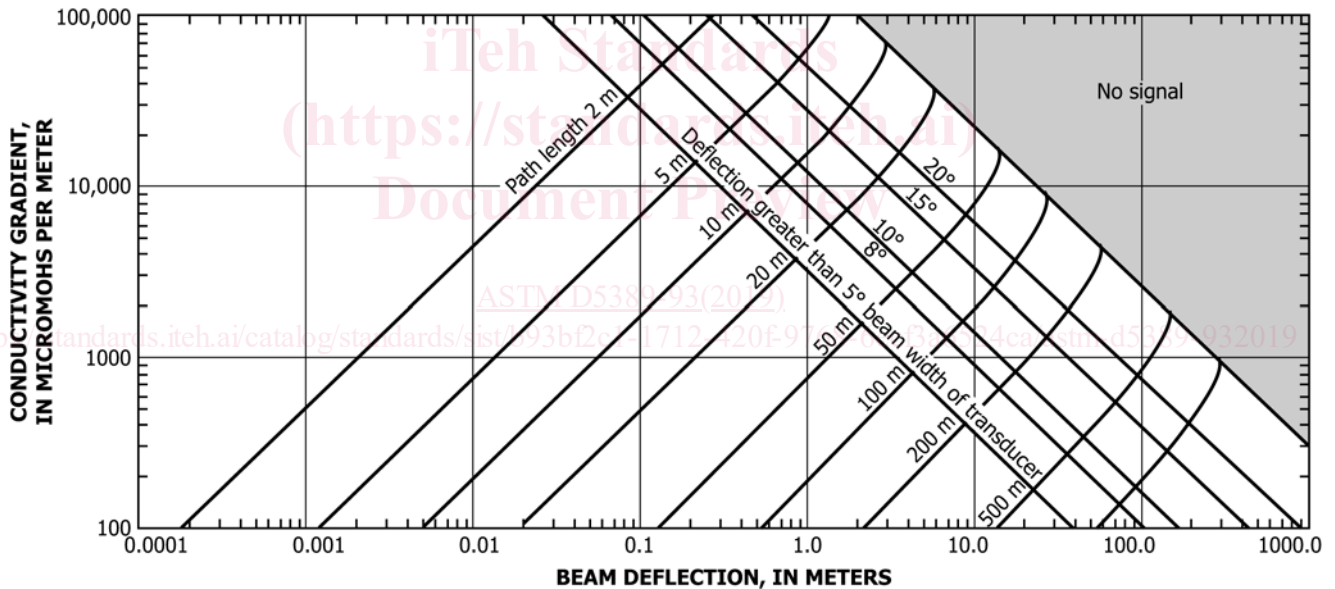

NOTE 1—Transducer directivity or beam width determined at the 30-dB level of the transmitted signal pattern. The signal is propagated beyond the beam width but at a weak level. In the shaded area the deflection is so great that signals cannot be received directly for any transducer beam width.

FIG. 6 Beam Deflection From Linear Conductivity Gradients for Different Path Lengths

maintain a minimum stream depth to path length ratio of 1 to 100 for path lengths greater than 50 m.

6.3 *Attenuation*—Acoustic signals are attenuated by absorption, spreading, or scattering. Absorption involves the conversion of acoustic energy into heat. Spreading loss is signal weakening as it spreads outward geometrically from its source. Scattering losses are the dominant attenuation factors in streamflow applications. These losses are caused by air

bubbles, sediment, or other particle or aquatic materials present in the water column. Table 1 presents tolerable sediment concentrations.

6.4 *Mechanical Obstructions*—Marine growth or waterborne debris may build up on transducers or weed growth, boats, or other channel obstructions may degrade propagation and timing of acoustic signals.

TABLE 1 Estimates of Tolerable Sediment Concentrations for AVM System Operation Based on Attenuation From Spherical Spreading and From Scattering From the Most Critical Particle Size

NOTE 1—Sediment concentrations in milligrams per litre.

Selected Transducer Frequency (kHz)	Path distance (m)							
	5	20	50	100	200	300	500	1000
1000	6300	1200	400	—	—	—	—	—
500	—	3500	1200	530	230	—	—	—
300	—	7900	2800	1300	560	350	—	—
200	—	11 000	4000	1800	830	520	280	—
100	—	—	10 000	4600	2200	1400	770	350
30	—	—	—	—	8800	5700	3200	1500

6.5 *Electrical Obstructions*—Nearby radio transmitters, electrical machinery, faulty electrical insulators, or other sources of electromagnetic interference (EMI) can cause failure or sporadic operation of AVMs.

7. Apparatus

7.1 The instrumentation used to measure open-channel flow by acoustic means consists of a complex and integrated electronic system known as an acoustic velocity meter (AVM). Three or four companies presently market AVM systems suitable for measurement of open-channel flow. System configurations range from simple single-path to complex-multi-path systems. Internal computation, transmission, and recording systems vary depending on local requirements. Most AVM systems must include the capability to compute an acoustic line velocity from one or more path velocities together with stage (water level) and other information related to channel geometry necessary to calculate a flow rate per unit of time, usually cubic millimetres per second (m^3/s) or cubic feet per second (ft^3/s).

7.1.1 *Electronics Equipment*—There are several methods that are currently being used to implement the electro-acoustic functions and mathematical manipulations required to obtain a line-velocity measurement. Whatever method is used must include internal automatic means for continuously checking the accuracy. In addition, provision must be included to prevent erroneous readings during acoustic interruptions caused by river traffic, aquatic life, or gradual degradation of components.

7.1.2 *Flow Readout Equipment*—This equipment is functionally separated into three subsystems. These subsystems may or may not be physically separable but are discussed separately for clarity.

7.1.3 *Acoustic Tranceiver*—This system generates, receives, and measures the traveltimes of acoustic signals. The acoustic signals travel between the various pairs of acoustic transducers and form the acoustic paths from which line velocities are determined.

7.1.4 *Processor*—The processor performs the mathematical operations required to calculate acoustic line velocities, makes decisions about which acoustic paths should be used on the basis of stage, performs error checking, calculates total volume flow rate, and totalizes volume flow.

7.1.5 *Display/Recorder*—Generally, the output of the system is a display or a recorder, or both. The recorder normally includes calendar data, time, flow rate, stage, and any other information deemed desirable, such as error messages. Equipment of this type is often connected to other output devices, such as telemetry equipment.

7.2 *Acoustic Transducers*—Transducers may be active (containing Transmitter and first stage of amplification) or passive (no amplification) depending on path length and presence of electromagnetic interference EMI. Acoustic transducers must be rigidly mounted in the channel wall or bottom. Means must be provided for precise determination of acoustic path elevation, length, and angle to flow. The transducers and cabling must be sufficiently rugged to withstand the handling and operational environment into which they will be placed. Additionally, provision shall be made for simple replacement of transducer or cable, or both, in the event of failure or damage.

7.3 *Stage Measuring Device*—There are several methods for measuring stage and inputting this information to the system. The actual method used depends on the particular installation requirements. Some examples include visual measurement/manual keyboard entry, float/counterweight or bubbler systems with servo manometers connected to analog conversion equipment or digital encoders, upward looking acoustic transducers, or other electronic pressure sensors.

7.4 *Power Supply*—Several vendors currently offer battery-powdered AVMs as well as systems operating on 110 V ac standard commercial electric power. Availability of electricity should be considered during site evaluation prior to equipment selection.

7.5 *Cabling*—All interconnected cabling to and from transducers shall be armored or protected, or both, to minimize damage during installation and operation.

7.6 *Responders*—A responder is an electronic device that receives an acoustic signal and then retransmits it back across the stream after a predetermined time interval. A responder is used where direct wire connection is impractical. A typical responder system is shown in Fig. 7.

8. Sampling

8.1 Sampling, as defined in Terminology D1129, is not applicable to this test method.

9. Preparation of Apparatus

9.1 Site Selections:

9.1.1 *Channel Geometry*—The gaged site should be in a section of channel that is straight for three to ten channel widths upstream and one to two channel widths downstream. The banks should be parallel and not subject to overflow. There should be minimal change in cross-section area between the upstream and downstream transducer locations. Calibrating discharge measurements must be made along the acoustic path where large differences exist in cross-sectional area between the upstream and downstream transducers. AVMs are not usually suitable for wide shallow channels, except by using multiple horizontal paths.

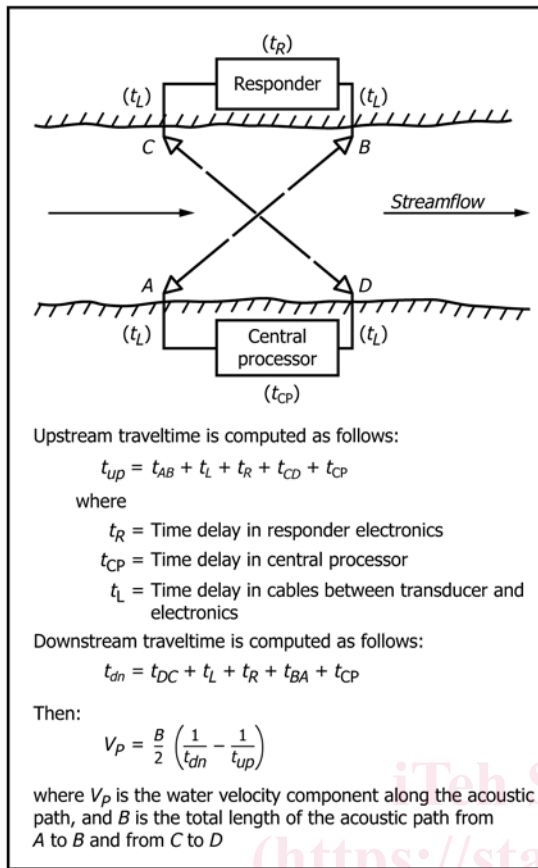

FIG. 7 Responder System

9.1.2 *Channel Stability*—The cross sections should not be subject to frequent shifting and the relationship between stage and cross-section area must be stable or frequently measured. Sites with unstable vertical velocity profiles should be avoided, or additional acoustic paths added within the vertical to obtain improved velocity averaging.

9.1.3 *Water Temperature Gradients*—Refraction of the acoustic signal is caused by temperature gradients in the water, and signal loss and resulting loss of accuracy may result. Channel reaches that maintain deep water during low-flow periods (with consequent low mean velocities) may suffer from this problem during periods of high insolation.

9.1.4 *Water Density Effects*—Problems may be encountered at sites subject to the periodic intrusion of saline or brackish water, or where waters of differing density arising from other causes may be encountered. The effects will be similar to those associated with water temperature gradients. The key factor here is the periodic nature of the intrusion. The AVM techniques are not precluded from use in brackish or saline waters but, if a density interface is present at the gage location, signal loss due to refraction or reflection may occur. In wide estuaries, brackish water intrusions may cause cross-gradients and in such situations, time may need to be allowed for the flow to stabilize before measurements can be taken.

9.1.5 *Sediment Load*—The presence of suspended solids in the water may have a significant effect upon signal attenuation, causing both reflection and scatter. Signal loss from high

sediment concentration is highly dependent on path length and transducer frequency, as shown in Table 1. At locations where concentrations greater than 1000 mg/L may be experienced for significant periods, or where reliable measurements is particularly important under such conditions, the ultrasonic technique may not be suitable.

9.1.6 *Weed Growth*—The gage cross section should be free of weed growth, that seriously attenuates the acoustic signal. Different types of weed may have different properties, because it is the air included within the plant structure that produces the unwanted effect.

9.1.7 *Entrained Air*—The presence of significant amounts of entrained air bubbles in the water may cause problems due to reflection and scattering of the propagated acoustic wave. Locations that are downstream of dams, weirs, waterfalls, or mill or power plant tail-races may suffer from this problem. Air entrainment from these hydraulic structures may persist for several kilometers downstream or 5 to 10 min from the source.

9.1.8 *Remotely-Generated Hydraulic Effects*—Hydraulic uniformity of a gage site is an important attribute. Velocity profiles that depart significantly from the ideal may be engendered by bed, bank, or tributary confluence conditions at locations remote from the gage location itself, but may persist to have an effect at the gage. They may be present during some river-flow states, but not during others. Locations close to tributary streams having hydrological regimes different from those of the main stream should be avoided.

9.1.9 *Tributary Effects*—The ultrasonic technique works most reliably where the physical properties of the water in the channel reach to be gaged are as nearly homogeneous as possible. In situations where an upstream tributary is injecting water of a significantly different physical character, difficulties may result. Usually these differences will be in the water temperature or suspended sediment load. Full mixing of the two bodies of water to a homogeneous state may not be achieved for a considerable distance downstream of the confluence.

9.1.10 *Ambient Electrical Noise*—The effective functioning of ultrasonic technique depends upon the reliability and sensitivity of electronic technology. Some instrumentation designs may suffer significantly from the effects of ambient electrical noise (EMI), which may originate quite a distance away from the gage location. Powerful radio transmitters located many kilometres away from the gage may be a cause of difficulty. Most of these problems can be overcome by the use of active transducers, which greatly reduce the ratio of signal to noise on the transmission cabling.

9.2 *Channel Environment, Width and Depth Constraints*—In general, the transducer operating frequency used in a particular application depends on the acoustic path length, the minimum clearance between the acoustic path and adjacent acoustic reflectors (for example, surface and bottom), and the expected silt load or amount of entrained air, or both. If there were no sound absorption in water or spreading losses, the highest possible operating frequency would be used because this increases system timing accuracy and allows closer spacing between the acoustic path and the surface or bottom of