



Designation: D7724 – 18<sup>ε1</sup>

# Standard Test Method for Carbon Black—Non-Dispersible Matter by Mechanical Flushing (NDM)<sup>1</sup>

This standard is issued under the fixed designation D7724; the number immediately following the designation indicates the year of original adoption or, in the case of revision, the year of last revision. A number in parentheses indicates the year of last reapproval. A superscript epsilon ( $\epsilon$ ) indicates an editorial change since the last revision or reapproval.

<sup>ε1</sup> NOTE—Corrected Section 11 editorially in January 2020.

## 1. Scope

1.1 This test method covers the determination of non-dispersible matter after mechanical water flushing of regular untreated carbon blacks. It may not be applicable to oil-treated carbon blacks because the oil would prevent proper wetting of the black by water.

1.2 The values stated in SI units are to be regarded as standard. No other units of measurement are included in this standard.

1.3 *This standard does not purport to address all of the safety concerns, if any, associated with its use. It is the responsibility of the user of this standard to establish appropriate safety, health, and environmental practices and determine the applicability of regulatory limitations prior to use.*

1.4 *This international standard was developed in accordance with internationally recognized principles on standardization established in the Decision on Principles for the Development of International Standards, Guides and Recommendations issued by the World Trade Organization Technical Barriers to Trade (TBT) Committee.*

## 2. Referenced Documents

2.1 *ASTM Standards:*<sup>2</sup>

**D1799 Practice for Carbon Black—Sampling Packaged Shipments**

**D1900 Practice for Carbon Black—Sampling Bulk Shipments**

**D4483 Practice for Evaluating Precision for Test Method Standards in the Rubber and Carbon Black Manufacturing Industries**

<sup>1</sup> This test method is under the jurisdiction of ASTM Committee D24 on Carbon Black and is the direct responsibility of Subcommittee D24.31 on Non-Carbon Black Components of Carbon Black.

Current edition approved June 1, 2018. Published July 2018. Originally approved in 2011. Last previous edition approved in 2016 as D7724 – 11 (2016). DOI: 10.1520/D7724-18E01.

<sup>2</sup> For referenced ASTM standards, visit the ASTM website, www.astm.org, or contact ASTM Customer Service at service@astm.org. For *Annual Book of ASTM Standards* volume information, refer to the standard's Document Summary page on the ASTM website.

## E11 Specification for Woven Wire Test Sieve Cloth and Test Sieves

## 3. Summary of Test Method

3.1 A sample of carbon black is mechanically flushed with water through a wire-mesh screen of a specified size until all that remains is a non-dispersible matter of carbon black. The non-dispersible matter is dried, weighed, and the amount of residue is expressed as mg/kg (ppm) of the original sample.

## 4. Significance and Use

4.1 The quantity of non-dispersible matter of carbon black is important in some molded or extruded products as it may relate to the surface appearance of those products. The maximum amount of non dispersible matter and the minimum size of the particles to be analyzed in each application is normally determined and agreed to between the user and the producer.

## 5. Apparatus

5.1 *Sieve Apparatus*, as shown in Fig. 1.<sup>3</sup>

5.2 *Balance*, with a sensitivity of 0.01 g.

5.3 *Analytical Balance*, with a sensitivity of 0.1 mg.

5.4 *Oven*, gravity-convection type, capable of temperature regulation within  $\pm 1^\circ\text{C}$  at  $125^\circ\text{C}$  and temperature uniformity within  $\pm 5^\circ\text{C}$ .

5.5 *Sieves*, diameter 100 mm, of either phosphor bronze or stainless steel.<sup>3</sup> The sieve shall be in accordance with Specification E11. The sieve size to be used shall be agreed upon between the purchaser and the carbon black manufacture.

5.6 *Weighing Dishes*.

## 6. Precautions

6.1 Install the apparatus as described in the manufacturer's instructions and keep it clean at all times to prevent contamination.

<sup>3</sup> The sole source of supply of the apparatus known to the committee at this time is Krahn IQS, GmbH, Paffrather Str. 13–15, D-51069 Koeln, Germany. If you are aware of alternative suppliers, please provide this information to ASTM International Headquarters. Your comments will receive careful consideration at a meeting of the responsible technical committee,<sup>1</sup> which you may attend.

TEST SET NDA VACU

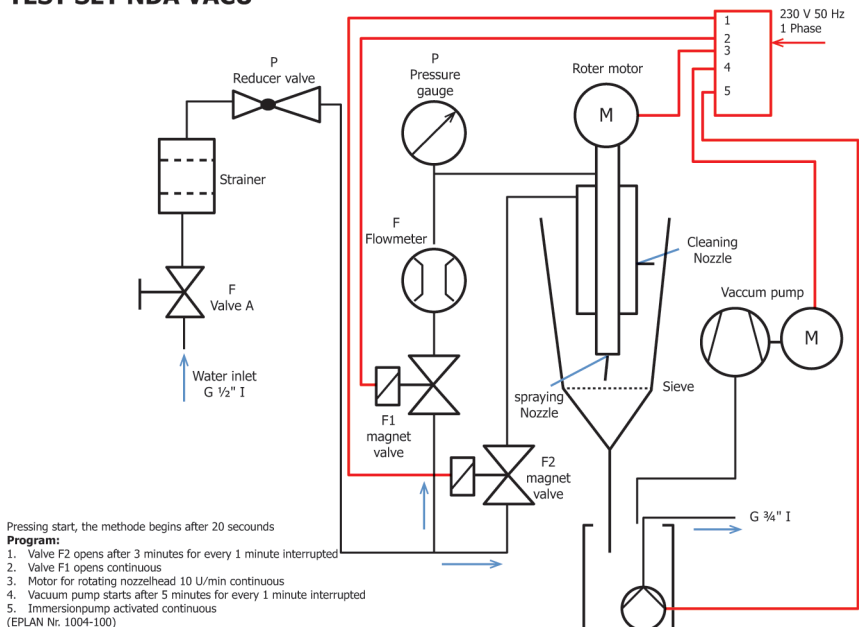

FIG. 1 Schematic Diagram of NDA Test Equipment

6.2 Examine the sieves each time they are used to make sure that no cracks or holes have developed.

7. Sampling

7.1 Samples shall be taken in accordance with Practice D1799 or Practice D1900.

8. Procedure

8.1 Prior to each test series adjust the water pressure to 400 ± 20 kPa in accordance with the manufacturer’s instructions. Make sure that only the spraying nozzle is operating when pressure is adjusted.

NOTE 1—The pressure will drop when the cleaning nozzles are operating in addition to the spraying nozzle.

8.2 Attach the sieve to the apparatus in accordance with the manufacturer’s instructions and push the “flush” button for at least 5 s. The water is flushed through the nozzles as long as the “flush” button is pushed.

8.3 After releasing the “flush” button disassemble the sieve and examine the sieve for particles. If no particles are observed reattach the sieve.

8.4 Weigh 500 ± 5 g of the sample into a container and transfer the sample quantitatively into the cylinder of the test apparatus. Note the correct weight for the calculation of the non dispersible matter.

8.5 Press the “start” button and close the lid slowly while the spraying nozzle is rotating without any water flushing. The flushing process will start automatically.

8.6 Based on a predefined program the sample will be flushed through the sieve by the water spray nozzles. For details refer to Fig. 1.

8.7 A vacuum is applied periodically to keep the non dispersible particles immobilized on the sieve in order to wash dispersible product from the non dispersible matter. The vacuum application is also part of the automated process.

8.8 The end of the test is indicated by a vacuum application without any water flowing. After that the measurement stops.

8.9 Disassemble the sieve and dry in an oven at a temperature of 125°C for 1 h.

8.10 Quantitatively transfer the non dispersible matter to a tared weighing dish and weigh to the nearest 0.1 mg using the analytical balance.

9. Calculation

9.1 Calculate the non-dispersible matter to the nearest mg/kg (ppm) as follows:

$$R = (W/S) \times 10^6 \quad (1)$$

where:

- R = Non-dispersible matter (NDM), mg/kg (ppm),
- W = mass of sieve residue, g, and
- S = mass of sample, g.

10. Report

10.1 Report the following information:

- 10.1.1 Proper identification of the sample,
- 10.1.2 Identification of the sieve size, and