



Designation: D5132 – 19

Standard Test Method for Horizontal Burning Rate of Polymeric Materials Used in Occupant Compartments of Motor Vehicles¹

This standard is issued under the fixed designation D5132; the number immediately following the designation indicates the year of original adoption or, in the case of revision, the year of last revision. A number in parentheses indicates the year of last reapproval. A superscript epsilon (ϵ) indicates an editorial change since the last revision or reapproval.

1. Scope*

1.1 This test method is intended for use as a small-scale laboratory procedure for comparing the relative horizontal burning rates of polymeric materials used in occupant compartments of motor vehicles.

1.2 During the course of combustion, gases or vapors, or both, are evolved that are potentially hazardous to personnel. Adequate precautions shall be taken to protect the operator.

1.3 *Units*—The values stated in SI units are to be regarded as standard.

1.4 This test method, Federal Safety Standard MVSS 302, SAE J369, and ISO 3795 address the same subject matter, but differ in technical content.

1.5 *This standard is used to measure and describe the response of materials, products, or assemblies to heat and flame under controlled conditions, but does not by itself incorporate all factors required for fire hazards or fire risk assessment of materials, products, or assemblies under actual fire conditions.*

1.6 *This standard does not purport to address all of the safety concerns, if any, associated with its use. It is the responsibility of the user of this standard to establish appropriate safety, health, and environmental practices and determine the applicability of regulatory limitations prior to use. Specific hazard statements are given in Section 7.*

1.7 *Fire testing is inherently hazardous. Adequate safeguards for personnel and property shall be employed in conducting these tests.*

NOTE 1—There is no known ISO equivalent to this standard.

1.8 *This international standard was developed in accordance with internationally recognized principles on standardization established in the Decision on Principles for the Development of International Standards, Guides and Recommendations issued by the World Trade Organization Technical Barriers to Trade (TBT) Committee.*

¹ This test method is under the jurisdiction of ASTM Committee D20 on Plastics and is the direct responsibility of Subcommittee D20.30 on Thermal Properties.

Current edition approved Dec. 1, 2019. Published January 2020. Originally approved in 1990. Last previous edition approved in 2017 as D5132 – 17. DOI: 10.1520/D5132-19.

2. Referenced Documents

2.1 ASTM Standards:²

- D883 Terminology Relating to Plastics
- D5025 Specification for Laboratory Burner Used for Small-Scale Burning Tests on Plastic Materials
- E176 Terminology of Fire Standards
- E456 Terminology Relating to Quality and Statistics
- E691 Practice for Conducting an Interlaboratory Study to Determine the Precision of a Test Method
- E2935 Practice for Conducting Equivalence Testing in Laboratory Applications

2.2 Federal Safety Standard:

- MVSS 302 (49 CFR 571.302) Flammability of Interior Materials-Passenger Cars, Multipurpose Passenger Vehicles, Trucks and Buses³

2.3 SAE Standard:

- SAE J369 Flammability of Polymeric Interior Materials - Horizontal Test Method⁴

2.4 ISO Standard:

- ISO 3795 Road vehicles, and tractors and machinery for agriculture and forestry—Determination of burning behavior of interior materials⁵

3. Terminology

3.1 *Definitions*—Terms used in this standard are defined in accordance with D883, unless otherwise specified. For terms relating to precision and bias and associated issues, the terms used in this standard are defined in accordance with Terminology E456. For terms relating to fire, the terms in this standard are defined in accordance with Terminology E176.

² For referenced ASTM standards, visit the ASTM website, www.astm.org, or contact ASTM Customer Service at service@astm.org. For *Annual Book of ASTM Standards* volume information, refer to the standard's Document Summary page on the ASTM website.

³ United States Code of Federal Regulations, 49 CFR 571.302, 36 FR 28991, available from Superintendent of Documents, U.S. Government Printing Office, Washington, DC 20402.

⁴ Available from Society of Automotive Engineers (SAE), 400 Commonwealth Dr., Warrendale, PA 15096-0001.

⁵ Available from International Organization for Standardization (ISO), 1 rue de Varembe, Case postale 56, CH-1211, Geneva 20, Switzerland.

*A Summary of Changes section appears at the end of this standard

4. Summary of Test Method

4.1 This test method employs a standard test specimen (100 by 356 mm) with a thickness up to 13 mm, mounted in a U-shaped metal frame. The specimen is ignited by means of a 38 mm high flame from an appropriate burner, and the burning rate of the material is determined.

4.2 The rate of burning is determined by measurements of the horizontal distance burned in relation to the time of burning, and reported for each set of specimens.

5. Significance and Use

5.1 This test method provides a standard laboratory procedure for measuring and comparing the burning rates of polymeric materials under specified controlled conditions.

5.2 The rate of burning is affected by such factors as density, direction of rise, and type and amount of surface treatments. The thickness of the finished specimens must also be taken into account. These factors must be considered in order to compare materials on the same basis.

5.3 In this procedure, the specimens are subjected to one or more specific sets of laboratory test conditions. If different test conditions are substituted or the end-use conditions are changed, it is not always possible by or from this test method to predict changes in the fire-test-response characteristics measured. Therefore, the results are valid only for the fire test exposure conditions described in this procedure.

6. Apparatus

6.1 The apparatus shall be as shown in Figs. 1-6 and shall include the following:

6.1.1 *Test Chamber*—A chamber approximately 380 by 355 by 200 mm constructed of 1.25–1.50 mm steel sheet and fabricated in accordance with Fig. 1.

6.1.2 *Laboratory Burner*—Constructed in accordance with Specification D5025.

NOTE 2—It is acceptable to mount the burner on the door, as shown in Fig. 6, to ensure proper alignment.

6.1.3 *Gas Supply*—Methane or natural gas having a heating value of $37 \pm 1 \text{ MJ/m}^3$.

6.1.4 *Specimen Holder Support*—A device capable of maintaining the specimen holder horizontally in place so that the top of the burner tube is positioned 19 mm below the top surface of the bottom U-shaped frame when placed in the specimen holder support, as shown in Fig. 2 and Fig. 3. The base of the support shall not obstruct the ventilation holes in the base of the cabinet.

NOTE 3—Limited data indicates that the use of a “drip tray” under the specimen holder does not significantly affect the test results. If differences are observed by the testing laboratory, the drip tray shall be removed.

6.1.5 *Specimen Holder*—Two matching U-shaped frames of non-corroding metal stock 25 mm wide and 10 mm high. The interior dimensions of the U-shaped frames are 50 mm wide by 330 mm long. A specimen that softens and bends at the flaming end so as to cause erratic burning is kept horizontal by supports consisting of thin, heat-resistant wires, spanning the width of the U-shaped frame under the specimen at 25-mm intervals. A device that is suitable for use for supporting this type of material is an additional U-shaped frame containing the specimen, spanned by 0.25-mm wires of heat-resistant composition at 25 mm intervals starting 38 mm from the open end. The device is inserted over the bottom U-shaped frame. See Fig. 4 and Fig. 5.

6.1.6 *Timing Device*—A timer accurate to the nearest 0.1 s.

6.1.7 *Measuring Device*—A rule accurate to the nearest 1.0 mm.

7. Hazards

7.1 During the course of combustion, gases or vapors, or both, are evolved and have the potential to be hazardous. Precautions shall be taken to protect the operator.

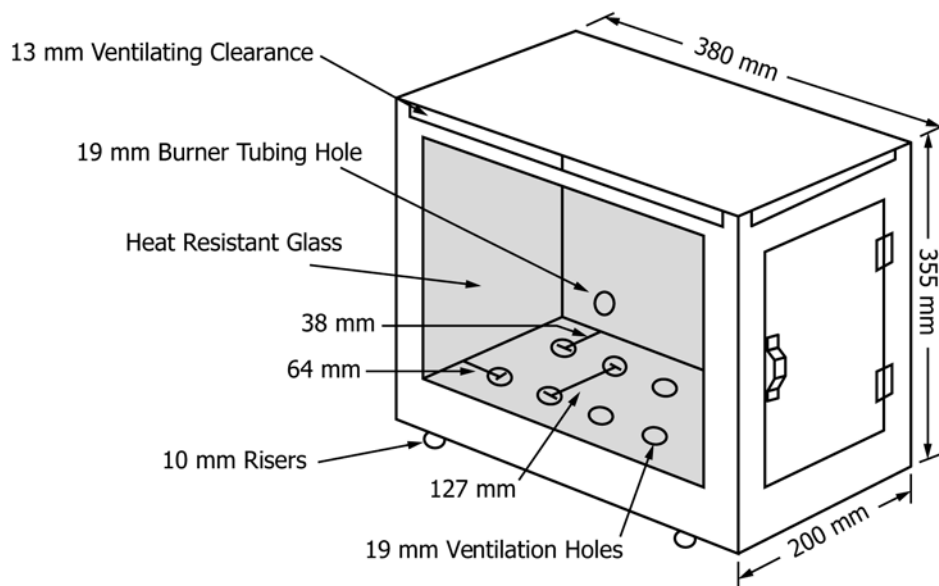

FIG. 1 Horizontal Flammability Chamber

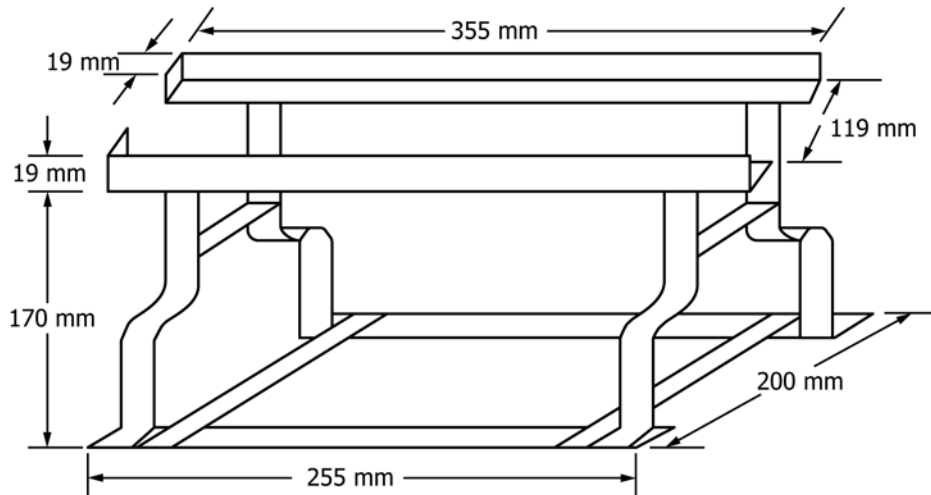

FIG. 2 Typical Specimen Holder Support

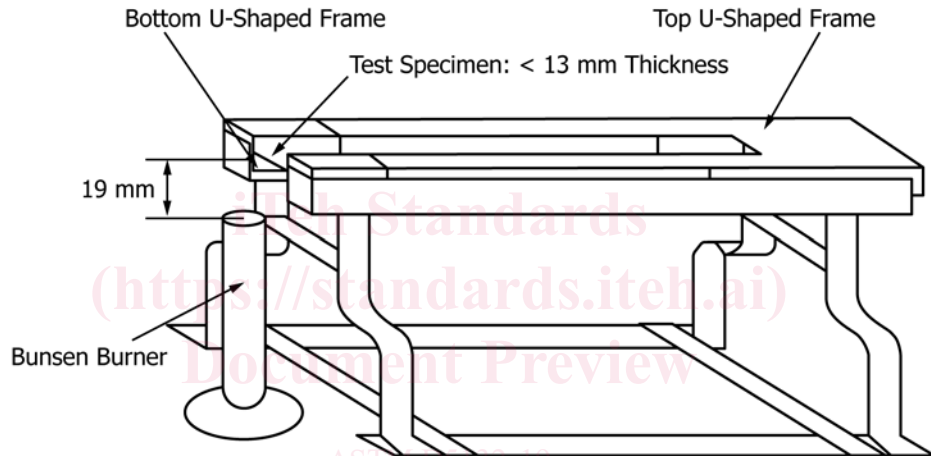

FIG. 3 Specimen Holder With Specimen Positioned in the Specimen Holder Support

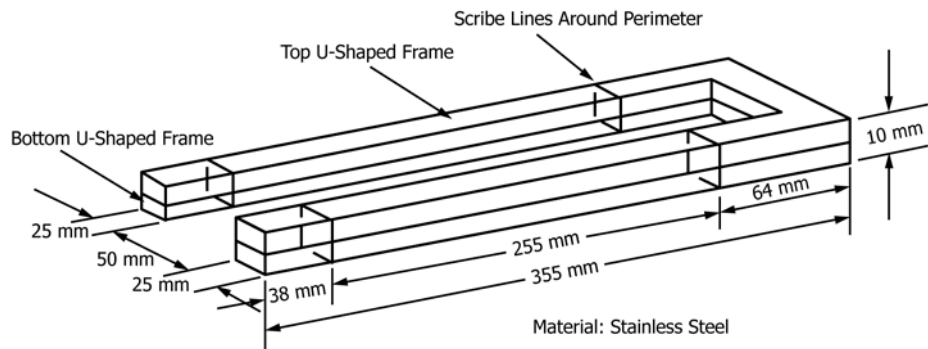

FIG. 4 Typical Specimen Holder—Two Identical U-Shaped Frames

8. Test Specimens

8.1 A minimum of five specimens 100 ± 5 mm wide by a minimum of 300 mm long by thickness up to a maximum of 13 mm are prepared by cutting from the test material. If the test material has a coating, covering, or construction that is considered directional in nature, and it has a directional effect on the burning rate, then specimens are produced by cutting five specimens in both the transverse and longitudinal directions.

8.2 Cut specimens from uniform density samples. The maximum thickness of any specimen shall be 13 mm. If any material to be tested exceeds this, it shall be cut to the above thickness by a mechanical process applied to the side which does not face the occupant compartment, so that the specimen shall include the primary surface of the part. In case of materials made of different composition which are not composite materials, all the layers within a depth of 13 mm from the surface facing towards the occupant compartment shall be