



Designation: C1892/C1892M – 19

Standard Test Methods for Strength of Anchors in Masonry ¹

This standard is issued under the fixed designation C1892/C1892M; the number immediately following the designation indicates the year of original adoption or, in the case of revision, the year of last revision. A number in parentheses indicates the year of last reapproval. A superscript epsilon (ϵ) indicates an editorial change since the last revision or reapproval.

1. Scope

1.1 These test methods address the tensile and shear strengths of post-installed and placed-during-construction anchors in masonry test specimens made of masonry assemblies. Environmental exposures include freezing and thawing, moisture, decreased and elevated temperatures and corrosion. These test methods provide basic testing procedures for use with product-specific evaluation and acceptance standards and are intended to be performed in a testing laboratory. Product-specific evaluation and acceptance standards may add specific details and appropriate parameters as needed to accomplish the testing. Only those tests required by the specifying authority need to be performed.

1.2 Loadings include quasi-static, dynamic, fatigue and shock. Environmental exposures include freezing and thawing, moisture, decreased and elevated temperatures and corrosion.

1.3 These test methods are intended for use with post-installed and placed-during-construction anchors designed for installation projecting from the surface of a masonry test specimen.

1.4 This standard prescribes separate procedures for static, dynamic, fatigue and shock testing. Nothing in this standard, however, shall preclude combined tests incorporating two or more of these types of loading (such as dynamic, fatigue and shock tests in series).

1.5 Both inch-pound and SI units are provided in this standard. The testing may be performed in either system and reported in that system and the results converted to the other. However, anchor diameters, threads, and related testing equipment shall be in accordance with either inch-pound or SI provisions.

1.6 *Units*—The values stated in each system are not necessarily exact equivalents; therefore, to ensure conformance with the standard, each system shall be used independently of the other, and values from the two systems shall not be combined.

1.7 *This standard does not purport to address all of the safety concerns, if any, associated with its use. It is the responsibility of the user of this standard to establish appropriate safety, health, and environmental practices and determine the applicability of regulatory limitations prior to use.*

1.8 *This international standard was developed in accordance with internationally recognized principles on standardization established in the Decision on Principles for the Development of International Standards, Guides and Recommendations issued by the World Trade Organization Technical Barriers to Trade (TBT) Committee.*

2. Referenced Documents

2.1 ASTM Standards:

[C1180 Terminology of Mortar and Grout for Unit Masonry](#)

[C1232 Terminology for Masonry](#)

[E4 Practices for Force Verification of Testing Machines](#)

[E468 Practice for Presentation of Constant Amplitude Fatigue Test Results for Metallic Materials](#)

[E575 Practice for Reporting Data from Structural Tests of Building Constructions, Elements, Connections, and Assemblies](#)

[E631 Terminology of Building Constructions](#)

2.2 Other Standards:

[ANSI B212.15 American National Standard for Cutting Tools—Carbide-Tipped Masonry Drills and Blanks for Carbide-Tipped Masonry Drills](#)

3. Terminology

3.1 For definitions of general terms related to building construction used in this standard, refer to Terminology [E631](#). For definitions of terms related to masonry refer to Terminology [C1180](#) or [C1232](#).

3.2 Definitions of Terms Specific to This Standard:

3.2.1 *adhesive anchor, n*—an anchor that derives its holding strength from the chemical compound between the wall of the hole and the anchor rod.

3.2.1.1 *Discussion*—The compounds used include epoxy, cementitious material, polyester resin, and other similar types.

3.2.2 *anchor spacing, n*—the distance between anchors measured centerline to centerline.

3.2.3 *placed-during-construction anchor, n*—an anchor that is installed prior to the placement of grout or mortar.

¹ This test method is under the jurisdiction of ASTM Committee C15 on Manufactured Masonry Units and is the direct responsibility of Subcommittee C15.04 on Research.

Current edition approved Dec. 1, 2019. Published January 2020. DOI: 10.1520/C1892_C1892M-19

3.2.3.1 *Discussion*—The anchor typically derives its holding strength from plates, lugs, or other protrusions that engage with the masonry assembly.

3.2.4 *displacement, n*—movement of an anchor relative to the masonry assembly.

3.2.4.1 *Discussion*—For tension tests, displacement is measured along the axis of the anchor, and for shear tests, displacement is measured perpendicular to the axis of the anchor.

3.2.5 *edge distance, n*—the distance from the centerline of an anchor to the nearest edge of a masonry test specimen.

3.2.6 *embedment depth, n*—distance from the masonry test specimen surface to the installed end of the anchor.

3.2.6.1 *Discussion*—The embedment depth is measured prior to any movement that results from anchor setting.

3.2.7 *expansion anchor, n*—an anchor that derives its holding strength through a mechanically expanded system which exerts forces against the sides of the drilled hole.

3.2.8 *fatigue test, n*—a laboratory test that applies repeated load cycles to an anchorage system for the purpose of determining the fatigue life or fatigue strength of that system.

3.2.9 *linear variable differential transformer (LVDT), n*—a device used for measuring the displacement or movement of an anchor or anchor system.

3.2.10 *masonry test specimen, n*—the masonry assembly in which an anchor is installed and which resists forces from the anchor.

3.2.11 *post-installed anchor, n*—an anchor that is installed after the placement and hardening of masonry.

3.2.12 *run-out, n*—a condition in which a failure does not occur in the specified number of load cycles in a fatigue test.

3.2.13 *safe working loads, n*—the allowable or design load obtained by applying factors of safety to the ultimate load of the anchorage device.

3.2.14 *dynamic test, n*—a laboratory test that applies load cycles of varying magnitude and frequency to an anchorage system for the purpose of simulating dynamic loads such as a seismic event (earthquake).

3.2.15 *shear test, n*—a test in which an anchor is loaded perpendicular to the axis of the anchor and parallel to the surface of the masonry test specimen.

3.2.16 *shock test, n*—a laboratory test that simulates shock loads on an anchorage system by the application of a short duration external load.

3.2.17 *static test, n*—a test in which a load is slowly applied to an anchor according to a specified rate such that the anchor receives one loading cycle.

3.2.18 *tensile test, n*—a test in which an anchor is loaded axially in tension.

3.2.19 *undercut anchor, n*—a post-installed anchor that derives its holding strength from an expansion of an embedded portion of the anchor into a portion of the hole that is larger in diameter than the portion of the hole between the enlarged section and the surface of the masonry test specimen.

3.2.19.1 *Discussion*—The enlarged diameter section of the hole is predrilled or enlarged by an expansion process during installation of the anchor.

3.3 Notation:

A_N and B_N	= instrument readings at a given load, in. [mm].
A_I and B_I	= initial instrument readings, in. [mm].
C_a	= minimum distance from the center of an anchor shaft to the edge of masonry test specimen, determined from tests, in. [mm].
d_m	= diameter of carbide-tipped drill bit with diameter on low end of tolerance range for new bit, representing moderately used bit, in. [mm].
d_{max}	= diameter of carbide-tipped drill bit with diameter on high end of tolerance range for new bit, representing bit as large as would be expected in use, in. [mm].
d_{min}	= diameter of carbide-tipped drill bit with diameter less than the low end of the tolerance range for new bit representing a well-used bit, in. [mm].
d_o	= outside diameter of anchor, in. [mm]
f'_m	= specified masonry compressive strength, psi [MPa].
h_{ef}	= effective embedment depth, measured from the masonry test specimen surface to the deepest point at which the anchor tension load is transferred to the masonry, in. [mm].
F_s	= safe working load, lb [N].
N_w	= tensile load in tests of anchors located in cracks whose opening width is cycled, lb [N].
s_{min}	= minimum anchor spacing, determined from test, in. [mm].
S	= anchor spacing, in. [mm], measured centerline to centerline.
Δ_T	= uncorrected displacement for tension tests, in. [mm].
Δ_S	= uncorrected displacement for shear tests, in. [mm].

4. Summary of Test Method

4.1 These test methods are intended to provide reproducible data from which acceptance criteria, design data, and specifications can be developed for anchors intended to be installed in masonry assemblies.

5. Apparatus

5.1 Equipment:

5.1.1 *General Laboratory*—Use calibrated electronic load and displacement measuring devices meeting the specified sampling rate. Use load-measuring equipment with an accuracy of $\pm 1\%$ of the anticipated ultimate load and calibrated in accordance with Practices E4. Use displacement measuring devices with an accuracy of ± 0.001 in. [± 0.025 mm]. For recording load and displacement measurements, use a data-acquisition system capable of recording at least 120 data points per instrument for each individual test, prior to reaching peak load. The testing equipment shall have sufficient capacity to prevent yielding of its components under the anticipated

ultimate load, and shall have sufficient stiffness to ensure that the applied tension loads remain parallel to the axes of the anchors and that the applied shear loads remain parallel to the surface of the masonry test specimen during testing.

5.1.2 *Tension Tests and Apparatus*—Examples of suitable systems for applying tension pull-out forces are shown in Figs. 1-3 in which a single anchor specimen is shown. The test system support shall be of sufficient size to prevent failure of the surrounding masonry test specimen, including any concentrated loading. The loading rod shall be of sufficient diameter to develop the anticipated ultimate strength of the anchorage hardware with an elastic elongation not exceeding 10 % of the anticipated elastic elongation of the anchor, and shall be attached to the anchorage system by a connector that will minimize the direct transfer of bending stress to the anchor. The displacement measuring device(s) shall be positioned to measure the movement of the test anchor with respect to the masonry test specimen so that the device is not influenced during the test by deflection, rotation, or failure of the anchor or masonry test specimen. See Figs. 1-3 for examples of typical test setups.

NOTE 1—Dual displacement sensors are often used to remove rotation related deformations.

5.1.3 *Shear Test and Apparatus*—Examples of suitable systems for applying shear forces are shown in Figs. 4-6 in which a single anchor specimen is shown. Position the displacement-measuring device(s) to measure displacement in the direction of the applied load only. Place the device on the masonry test specimen so that the sensing element bears perpendicularly on the anchor or on a contact plate located on the loading plate, or use another method that restricts deflections other than those in the direction of the applied load. For tests on anchor groups,

the axis of the displacement-measuring device shall coincide with the centroid of the group. Table 1 gives the minimum required clear distance from the anchor to the free edge of the masonry test specimen.

5.2 *Loading Plates:*

5.2.1 For tension loading the plate thickness in the immediate vicinity of the test anchor shall be equal to or greater than the nominal anchor diameter to be tested.

5.2.2 For shear testing the plate thickness in the immediate vicinity of the test anchor shall be equal to the nominal anchor diameter to be tested, $-\frac{1}{16} + \frac{1}{8}$ in. [$-1.6 + 3.0$ mm]. The hole in the loading plate shall have a diameter of 0.06 ± 0.03 in. [1.5 ± 0.8 mm] greater than the specified diameter of the test anchor unless another diameter is specified. The shape of the hole in the loading plate shall correspond to that of the anchor cross section. When sleeve inserts of the required diameter are used they shall be periodically inspected and replaced to meet these requirements and prevent eccentric loading of sleeve. See Fig. 7 for representative shear plates with sleeves. The contact area between the loading plate through which the anchor is installed and the masonry test specimen shall be as given in Table 2, unless otherwise specified. Chamfer or smooth the edges of the loading plate so that it does not dig into the masonry. Place a sheet of friction limiting material between the shear plate and the surface of the masonry test specimen member (see 6.4.3.1). The friction-limiting material shall prevent contact of the loading plate with the base material.

5.3 *Anchor Displacement Measurement*—For anchor tests that require displacement measurements, the displacement measurements shall be made using LVDT device(s) or equivalent which provide continuous readings with an accuracy of at least 0.001 in. [0.025 mm].

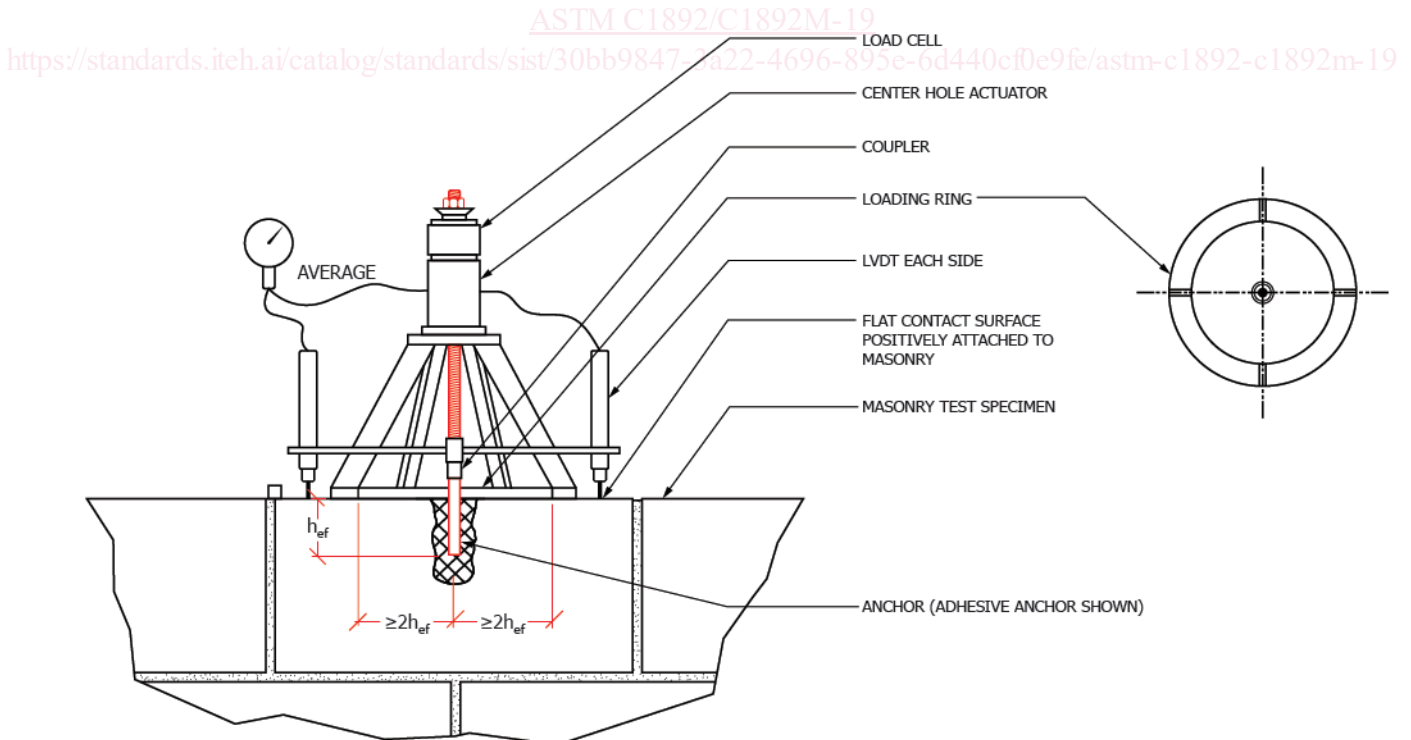

FIG. 1 Example of Tension Test Setup—Displacement Measurement with Dual LVDTs

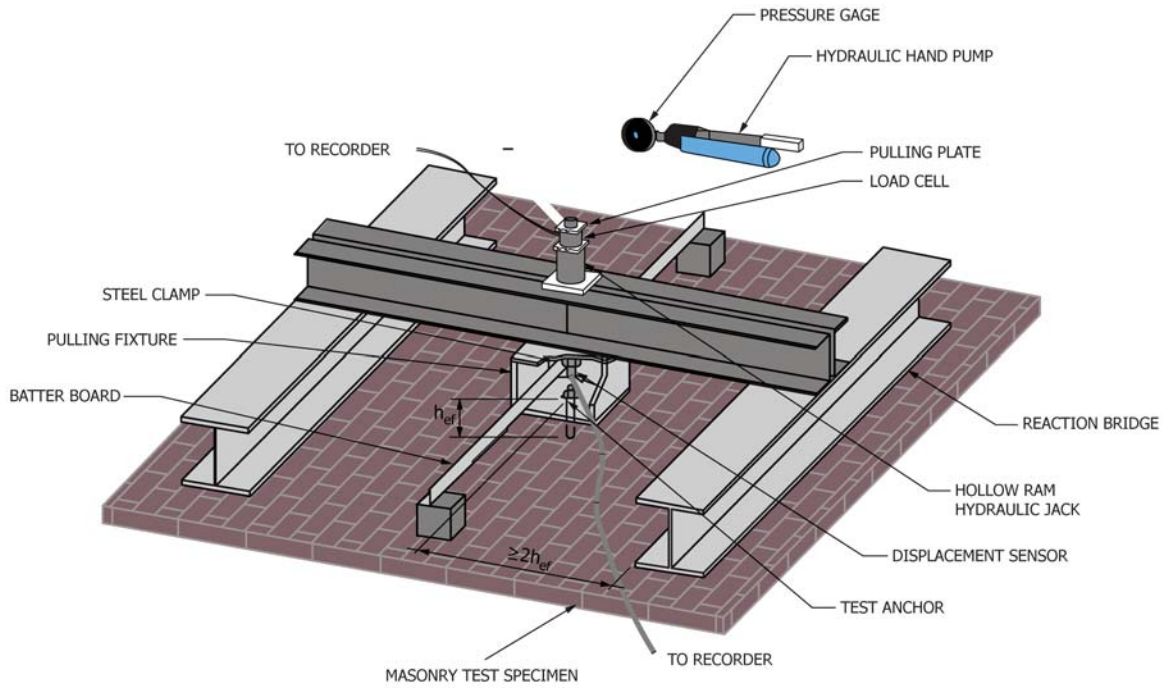

FIG. 2 Typical Static Tension Test Arrangement

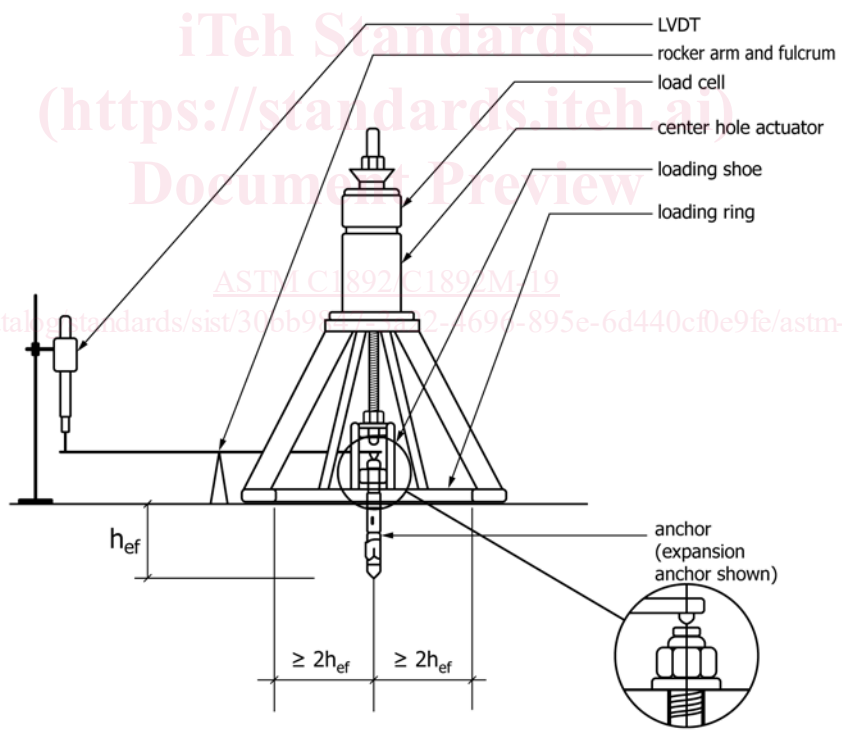

FIG. 3 Example of Tension Test Setup—Displacement Measurement from Top of Anchor

NOTE 1—Other support geometries are acceptable.

5.3.1 Tension Test:

5.3.1.1 Single Anchor—The displacement measuring device(s) shall be positioned to measure the vertical movement of the anchor with respect to points on the masonry test specimen in such a way that the device is not influenced during the test

by deflection, rotation, flexure, or failure of the anchor or masonry test specimen.

5.3.1.2 Group of Anchors—Displacement measurements shall be made on all anchors or group of anchors tested simultaneously except that only one set of instruments needs to

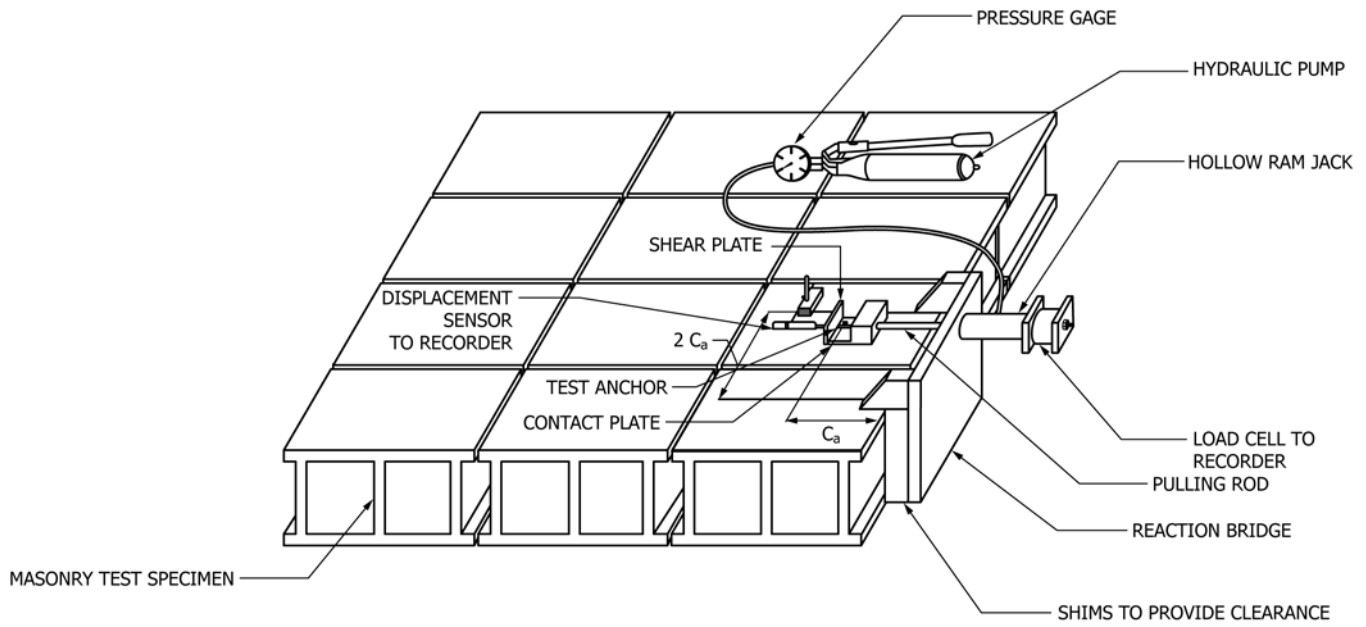

FIG. 4 Typical Method of Applying Shear Loads to Anchors Attached to Masonry Test Specimens—Direct Loading Method

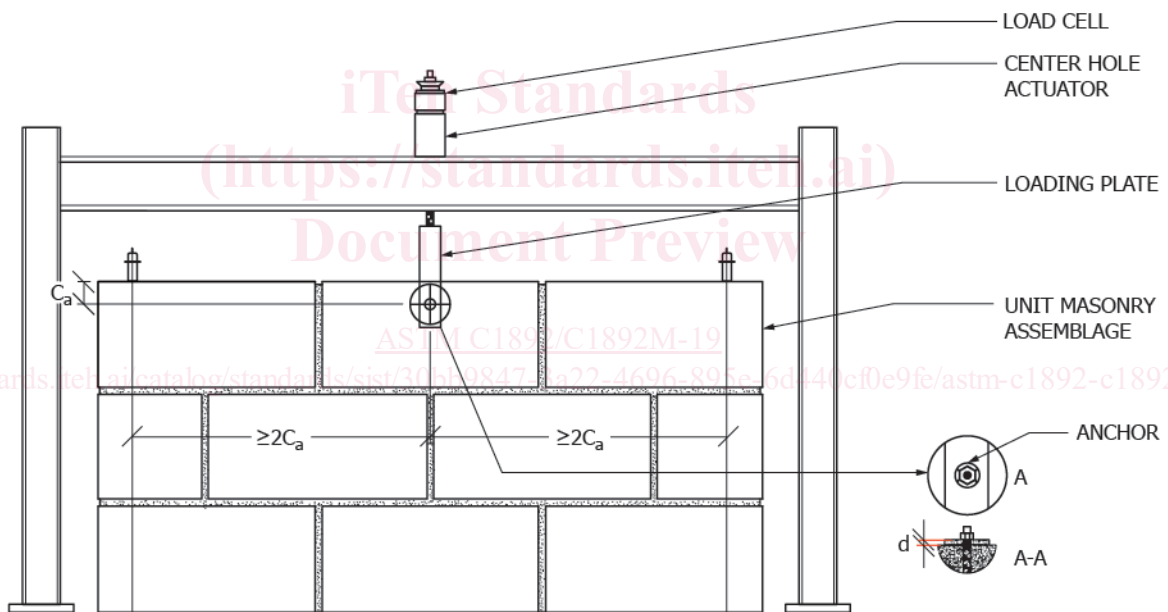

FIG. 5 Example of a Shear Test Setup Vertical Orientation

be used for a group of anchors tested as a closely spaced cluster. Displacement measurements will include components of deformation not directly associated with displacement of the anchor relative to the masonry test specimen. Include components of deformation such as elastic elongation of the loading rod anchor stem, deformation of the loading plate, sleeves, shims, attachment hardware, and masonry test specimen. Deduct all of the elongations from these sources from the total displacement measurements by using supplementary measuring devices or calibration test data for the installed test set-up with a rigid specimen replacing the anchor to be tested. The displacement to be used for the evaluation of the findings is the

average displacement indicated by both instruments mounted symmetrically equidistant from the centroid of the cluster as shown in Fig. 8.

5.3.2 *Shear Test*—The displacement measuring device(s) shall be positioned to measure displacement in the direction of the applied load. The device shall be placed on the masonry test specimen to allow the sensing element to bear perpendicularly on the anchor or on a contact plate located on the loading plate as shown in Figs. 4 and 5 or other methods which prevents extraneous deflections. For tests on clusters of anchors, the instrument shall lie on a plane through the axis of the shear

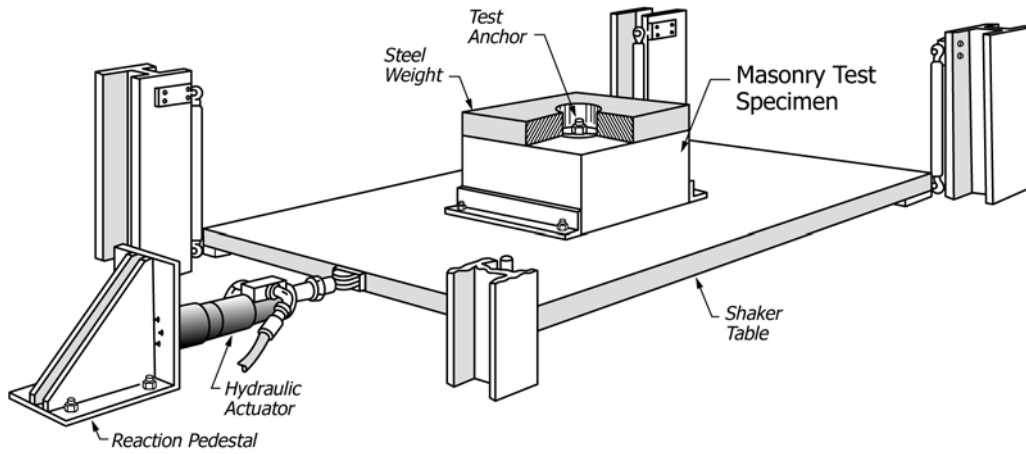

FIG. 6 Typical Dynamic Shear Test Arrangement—Indirect Loading Method

TABLE 1 Minimum Clearance Requirements for Test Equipment Supports

Adhesive Anchors ^A		All Other Anchors	
Spacing between Test Supports	Minimum Distance to Edge or Test Frame	Spacing between Test Supports	Minimum Distance to Edge or Test Frame
Tension Loads			
$2.0h_{ef}$	$1.0h_{ef}$	$4.0h_{ef}$	$2.0h_{ef}$
Shear Loads			
$4.0h_{ef}$	$2.0h_{ef}$	$4.0h_{ef}$	$2.0h_{ef}$

^AHybrid adhesive anchors shall use spacing and edge distance requirements for other anchors

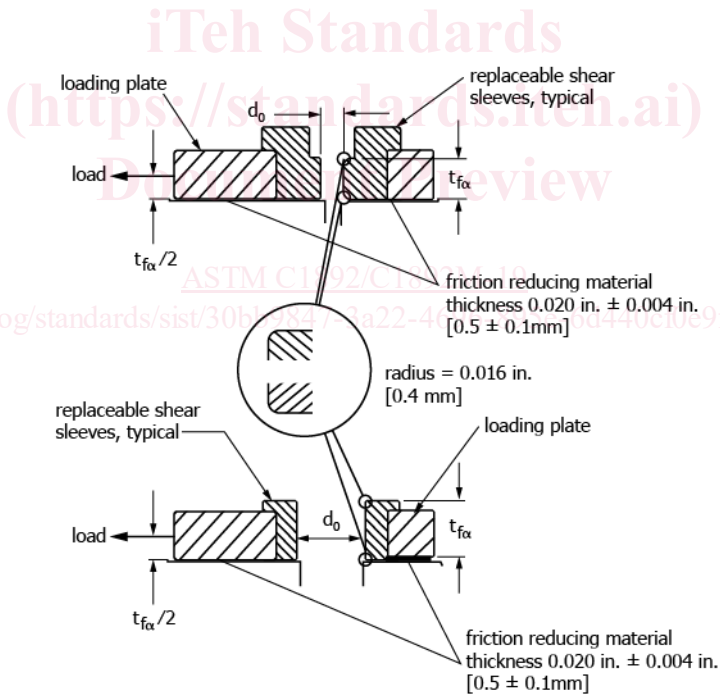

FIG. 7 Examples of Shear Plates with Sleeves

loading rod or plate. An extension of the axis of the shear loading rod or plate shall pass through the centric axis of the cluster of anchors.

6. Anchor and Masonry Wall Specimens

6.1 *Anchorage System*—The anchorage system shall be representative of the type and lot to be used in field construc-

tion and shall include all accessory hardware normally required for its use, that is, all attachment hardware.

6.2 *Anchor Installation*—Install the anchors according to the manufacturer’s instructions. Report the installation details in accordance with 14.1.7.