



Designation: D558/D558M – 19

Standard Test Methods for Moisture-Density (Unit Weight) Relations of Soil-Cement Mixtures¹

This standard is issued under the fixed designation D558/D558M; the number immediately following the designation indicates the year of original adoption or, in the case of revision, the year of last revision. A number in parentheses indicates the year of last reapproval. A superscript epsilon (ϵ) indicates an editorial change since the last revision or reapproval.

This standard has been approved for use by agencies of the U.S. Department of Defense.

1. Scope*

1.1 These test methods cover the determination of the relationship between the water content and the density of soil-cement mixtures when compacted before cement hydration as prescribed.

1.2 A 0.0333-ft³ [944-cm³] mold and a 5.50-lbf [24.5-N or mass of 2.5-kg] rammer dropped from a height of 12.0 in. [30.5 cm] are used and two methods, depending on soil gradation, are covered, as follows:

Test Method A, using soil material passing a No. 4 [4.75-mm] sieve. This method shall be used when 100 % of the soil sample passes the No. 4 [4.75-mm] sieve

Test Method B, using soil material passing a 3/4-in. [19.0-mm] sieve. This method shall be used when part of the soil sample is retained on the No. 4 [4.75-mm] sieve. This test method may be used only on materials with 30 % or less retained on the 3/4-in. [19.0-mm] sieve

Sections

8

9

1.3 *Units*—The values stated in inch-pound units or SI units are to be regarded separately as standard. The values stated in each system may not be exact equivalents; therefore, each system shall be used independently of the other. Combining values from the two systems may result in nonconformance with the standard.

1.3.1 The gravitational system of inch-pound units is used when dealing with inch-pound units. In this system, the pound (lbf) represents a unit of force (weight), while the unit for mass is slugs. The slug unit is not given, unless dynamic ($F=ma$) calculations are involved.

1.3.2 It is common practice in the engineering/construction profession to concurrently use pounds to represent both a unit of mass (lbm) and of force (lbf). This implicitly combines two separate systems of units; that is, the absolute system and the gravitational system. It is scientifically undesirable to combine the use of two separate sets of inch-pound units within a single standard. This standard includes the gravitational system of inch-pound units and does not use/present the slug unit for

mass. However, the use of balances or scales recording pounds of mass (lbm) or recording density in lbm/ft³ shall not be regarded as nonconformance with this standard.

1.4 All observed and calculated values shall conform to the guidelines for significant digits and rounding established in Practice D6026.

1.4.1 The procedures used to specify how data are collected/recorded and calculated in this standard are regarded as the industry standard. In addition, they are representative of the significant digits that should generally be retained. The procedures used do not consider material variation, purpose for obtaining the data, special purpose studies, or any considerations for the user's objectives; and it is common practice to increase or reduce significant digits of reported data to be commensurate with these considerations. It is beyond the scope of this standard to consider significant digits used in analysis methods for the engineering design.

1.5 *This standard does not purport to address all of the safety concerns, if any, associated with its use. It is the responsibility of the user of this standard to establish appropriate safety, health, and environmental practices and determine the applicability of regulatory limitations prior to use.*

1.6 *This international standard was developed in accordance with internationally recognized principles on standardization established in the Decision on Principles for the Development of International Standards, Guides and Recommendations issued by the World Trade Organization Technical Barriers to Trade (TBT) Committee.*

2. Referenced Documents

2.1 *ASTM Standards*:²

C150/C150M Specification for Portland Cement

C595/C595M Specification for Blended Hydraulic Cements

D559/D559M Test Methods for Wetting and Drying Compacted Soil-Cement Mixtures

¹ These test methods are under the jurisdiction of ASTM Committee D18 on Soil and Rock and are the direct responsibility of Subcommittee D18.15 on Stabilization With Admixtures.

Current edition approved Dec. 1, 2019. Published January 2020. Originally approved in 1938. Last previous edition approved in 2011 as D558–11. DOI: 10.1520/D0558_D0558M-19.

² For referenced ASTM standards, visit the ASTM website, www.astm.org, or contact ASTM Customer Service at service@astm.org. For *Annual Book of ASTM Standards* volume information, refer to the standard's Document Summary page on the ASTM website.

*A Summary of Changes section appears at the end of this standard



- D560/D560M Test Methods for Freezing and Thawing Compacted Soil-Cement Mixtures
- D653 Terminology Relating to Soil, Rock, and Contained Fluids
- D698 Test Methods for Laboratory Compaction Characteristics of Soil Using Standard Effort (12,400 ft-lbf/ft³ (600 kN-m/m³))
- D2168 Practices for Calibration of Laboratory Mechanical-Rammer Soil Compactors
- D2216 Test Methods for Laboratory Determination of Water (Moisture) Content of Soil and Rock by Mass
- D3740 Practice for Minimum Requirements for Agencies Engaged in Testing and/or Inspection of Soil and Rock as Used in Engineering Design and Construction
- D4753 Guide for Evaluating, Selecting, and Specifying Balances and Standard Masses for Use in Soil, Rock, and Construction Materials Testing
- D6026 Practice for Using Significant Digits in Geotechnical Data
- E11 Specification for Woven Wire Test Sieve Cloth and Test Sieves

3. Terminology

3.1 For definitions of common technical terms used in this standard, refer to Terminology D653.

4. Summary of Test Method

4.1 A soil-cement mixture at a selected molding water content is placed in three layers into a mold of given dimensions, with each layer compacted by 25 blows of a 5.50-lbf [24.5-N] rammer dropped from a distance of 12 in. [304.8 mm] subjecting the soil-cement mixture to a total compactive effort of about 12,400 ft-lbf/ft³ [600 kN-m/m³]. The resulting dry unit weight is determined. The procedure is repeated for a sufficient number of molding water contents to establish a relationship between the dry unit weight and the molding water content of the soil-cement. This data, when plotted, represents a curvilinear relationship known as a compaction curve. The values of optimum water content and standard maximum dry unit weight are determined from the compaction curve.

5. Significance and Use

5.1 These tests determine the optimum water content and maximum density (unit weight) to be used for molding soil-cement specimens in accordance with Test Methods D559/D559M and D560/D560M.

NOTE 1—Since these tests are used in conjunction with Test Methods D559/D559M and D560/D560M and the criteria referenced therein, the test differs in several aspects from Test Method D698. There are three main differences between this standard and Test Method D698. Firstly, this standard allows a maximum particle size of $\frac{3}{4}$ -in. [19.0 mm] for a 4-in. [101.6-mm] mold while Test Method D698 allows a maximum particle size of $\frac{3}{8}$ -in. [9.5-mm] for the same size mold. Secondly, this standard permits the material leftover after the water content specimen has been obtained to be mixed with the rest of the sample and reused for the next determination. Test Method D698 does not permit the material to be reused. Thirdly, this standard allows the material that is retained on the $\frac{3}{4}$ -in. [19.0-mm] and passing the 3-in. [75-mm] to be discarded (scalping technique) and replaced with an equal mass of material that passes the

$\frac{3}{4}$ -in. [19.0-mm] sieve and is retained on the No.4 [4.75-mm] sieve. Test Method D698 does not permit the scalp and replacement technique.

NOTE 2—The quality of the result produced by this standard is dependent on the competence of the personnel performing it, and the suitability of the equipment and facilities used. Agencies that meet the criteria of Practice D3740 are generally considered capable of competent and objective testing/sampling/inspection/etc. Users of this standard are cautioned that compliance with Practice D3740 does not in itself assure reliable results. Reliable results depend on many factors; Practice D3740 provides a means of evaluating some of those factors.

6. Apparatus

6.1 *Mold*—A cylindrical metal mold having a volume of 0.0333 ± 0.0005 ft³ [944 ± 14 cm³] with an average inside diameter of 4.000 ± 0.016 in. [101.6 ± 0.4 mm] and conforming to Fig. 1 to permit preparing compacted specimens of soil-cement mixtures of this size. The mold shall be provided with a detachable collar assembly approximately 2.5-in. [63.5 mm] in height. The mold may be of the split type consisting of two half-round sections or section of pipe with one side split perpendicular to the pipe circumference and that can be securely locked in place to form a closed cylinder having the dimensions described above. The mold and collar assembly shall be so constructed that it can be fastened firmly to a detachable base (Fig. 1).

6.2 *Rammer*—A rammer, either manually operated as described further in 6.2.1 or mechanically operated as described in 6.2.2. The rammer shall fall freely through a distance of 12.00 ± 0.05 in. [304.8 ± 1 mm] from the surface of the specimen. The weight of the rammer shall be 5.50 ± 0.02 lbf [24.5 ± 0.09 N, or mass of 2.495 ± 0.009 kg], except that the weight of the mechanical rammers may be adjusted as described in Practices D2168 (See Note 3). The striking face of the rammer shall be planar and circular, except as noted in 6.2.2, with a diameter when new of 2.000 ± 0.005 in. [50.80 ± 0.13 mm]. The rammer shall be replaced if the striking face becomes worn or bellied to the extent that the diameter exceeds 2.000 ± 0.01 in. [50.80 ± 0.25 mm].

NOTE 3—It is a common and acceptable practice to determine the weight of the rammer using either a kilogram or pound balance and assume 1 lbf is equivalent to 0.4536 kg, 1 lbf is equivalent to 1 lbm, or 1 N is equivalent to 0.2248 lbf or 0.1020 kg.

6.2.1 *Manual Rammer*—The rammer shall be equipped with a guide sleeve that has sufficient clearance that the free fall of the rammer shaft and head is not restricted. The guide sleeve shall have at least four vent holes at each end (eight holes total) located with centers $\frac{3}{4} \pm \frac{1}{16}$ in. [19.0 ± 2 mm] from each end and spaced 90 degrees apart. The minimum diameter of the vent holes shall be $\frac{3}{8}$ in. [9.5 mm]. Additional holes or slots may be incorporated in the guide sleeve.

6.2.2 *Mechanical Rammer-Circular Face*—The rammer shall operate mechanically in such a manner as to provide uniform and complete coverage of the specimen surface. There shall be 0.10 ± 0.03 in. [2.5 ± 0.8 mm] clearance between the rammer and the inside surface of the mold at its smallest diameter. The mechanical rammer shall meet the standardization/calibration requirements of Practices D2168. The mechanical rammer shall be equipped with a positive mechanical means to support the rammer when not in operation.

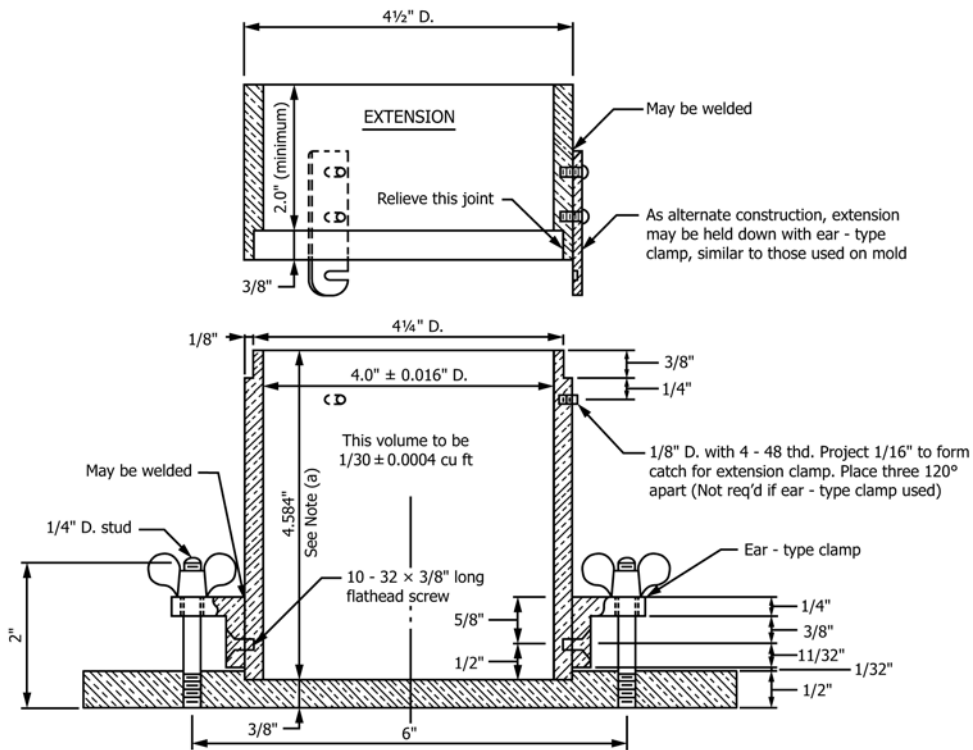

SI Equivalents

in.	mm
0.016	0.41
0.026	0.66
1/32	0.80
1/16	1.6
1/8	3.2
1/4	6.4
11/32	8.7
3/8	9.5
1/2	12.7
5/8	15.9
2	50.8
2 1/2	63.5
4	101.6
4 1/4	108.0
4 1/2	114.3
4.584	116.43
6	152.4
6 1/2	165.1
8	203.2

NOTE 1—(a)—The tolerance on the height is governed by the allowable volume and diameter tolerances.

NOTE 2—(b)—The methods shown for attaching the extension collar to the mold and the mold to the base plate are recommended. However, other methods are acceptable, providing the attachments are equally as rigid as those shown.

FIG. 1 Cylindrical Mold

6.2.3 *Mechanical Rammer-Sector Face* (See Note 4)—When used with the 6 in. [152.4 mm] mold, a sector face rammer may be used in place of the circular face rammer. The use of a sector face rammer should be noted in the test report. The specimen contact face shall have the shape of a sector of a circle of radius equal to 2.90 ± 0.02 in. [73.7 ± 0.5 mm]. The

rammer shall operate in such a manner that the vertex of the sector is positioned at the center of the specimen.

NOTE 4—The sector face rammer shall not be used to compact test specimens in accordance with Test Methods D559/D559M and D560/D560M, unless previous tests on like soils show strength and resistance to wetting-and-drying and freezing-and-thawing of specimens compacted