



Designation: **A955/A955M – 19** **A955/A955M – 20**

Standard Specification for Deformed and Plain Stainless Steel Bars for Concrete Reinforcement¹

This standard is issued under the fixed designation A955/A955M; the number immediately following the designation indicates the year of original adoption or, in the case of revision, the year of last revision. A number in parentheses indicates the year of last reapproval. A superscript epsilon (ϵ) indicates an editorial change since the last revision or reapproval.

1. Scope*

1.1 This specification covers deformed and plain stainless steel bars for concrete reinforcement in cut lengths and coils used in applications requiring resistance to ~~corrosion~~ corrosion, restrictive mechanical properties, or controlled magnetic permeability. This specification has a minimum actual tensile strength to actual yield strength ratio (Table 3). The standard sizes and dimensions of deformed bars and their numerical designation shall be those listed in [Table 1](#).

1.1.1 A supplementary requirement (S1) is provided for use where a controlled magnetic permeability product is required by the purchaser. ~~Supplementary requirement (S1)~~ Requirement S1 applies only when specified in the purchase order.

1.1.2 A supplementary controlled mechanical properties requirement (S2) is provided for use where a restricted yield strength range and a higher actual tensile to actual yield strength ratio is required by the purchaser. Supplementary Requirement S2 applies only when specified in the purchase order.

1.2 The chemical composition of the stainless steel alloy shall be selected for suitability to the application involved by agreement between the manufacturer and the purchaser. This is an important consideration in achieving the desired corrosion resistance or controlled magnetic permeability, or both, because these properties are not provided by all stainless steels.

1.3 Corrosion Resistance requirements are contained in Section 11 and [Annex A1](#) and the test procedures options are [Annex A2](#) (Rapid Macrocell Test) or [Annex A3](#) (Cracked Beam Test).

1.4 The requirements for introduction of new alloys into a mandatory chemical composition requirements table in this specification are given in [Annex A5](#).

1.5 Requirements for the relative deformation area of three-sided deformed bars are contained in [Annex A4](#).

1.6 Bars are of three minimum yield strength levels, namely, 60 000 psi [420 MPa], 75 000 psi [520 MPa], and 80 000 psi [550 MPa], designated as Grade 60 [420], Grade 75 [520], or Grade 80 [550], respectively.

1.7 Plain bars in sizes up to and including 2 in. [50.8 mm] in diameter in coils or cut lengths are furnished in accordance with this specification in Grade 60 [420], Grade 75 [520], and Grade 80 [550], respectively. Mechanical testing, when required, shall be to the nearest nominal deformed bar size. Requirements providing for deformations and marking shall not be applicable to plain bars.

1.8 When stainless steel is to be welded, use a procedure suitable for the chemical composition and intended use or service.

NOTE 1—Welding of stainless steel reinforcement would occur after shipment from the manufacturer. Structural welding should be performed in accordance with the latest edition of AWS D1.6/D1.6M, any other internationally accepted stainless steel welding code, or a procedure suggested by the material manufacturer. AWS D1.6/D1.6M describes the proper selection of the filler metals, temperature control, as well as, performance, procedure qualification and inspection requirements.

1.9 This specification is applicable for orders in either inch-pound units (as Specification A955) or in SI units (as Specification A955M).

1.10 The text of this specification references notes and footnotes which provide explanatory material. These notes and footnotes (excluding those in tables and figures) shall not be considered as requirements of the specification.

1.11 The values stated in either inch-pound or SI units are to be regarded separately as standard. Within the text, the SI units are shown in brackets. The values stated in each system may not be exact equivalents; therefore, each system shall be used independently of the other. Combining values from the two systems may result in nonconformance with the specification.

¹ This specification is under the jurisdiction of ASTM Committee A01 on Steel, Stainless Steel and Related Alloys and is the direct responsibility of Subcommittee A01.05 on Steel Reinforcement.

Current edition approved ~~May 15, 2019~~ Jan. 1, 2020. Published ~~May 2019~~ January 2020. Originally approved in 1996. Last previous edition approved in ~~2018~~ 2019 as ~~A955/A955M – 18b~~ A955/A955M – 19. DOI: ~~10.1520/A0955_A0955M-19~~ 10.1520/A0955_A0955M-20.

*A Summary of Changes section appears at the end of this standard

TABLE 1 Deformed Bar Designation Numbers, Nominal Weights [Masses], Nominal Dimensions, and Deformation Requirements

| Bar Designation No. | Nominal Weight, lb/ft [Nominal Mass, kg/m] ^A | | Nominal Dimensions ^B | | | Deformation Requirements, in. [mm] | | | |
|---------------------|---------------------------------------------------------|---------------|---------------------------------|-----------------------------------------------------------|---------------------|------------------------------------|------------------------|-----------------------------------|-----------------|
| | 400-Series; Duplex Alloys | 300 Series | Diameter, in. [mm] | Cross-Sectional Area, in. ² [mm ²] | Perimeter, in. [mm] | Maximum Average Spacing | Minimum Average Height | Maximum Gap per Side ^C | |
| | | | | | | | | Two-Sided Bar | Three-Sided Bar |
| 3 [10] | 0.374 [0.556] | 0.378 [0.562] | 0.375 [9.5] | 0.11 [71] | 1.178 [29.9] | 0.262 [6.7] | 0.015 [0.38] | 0.143 [3.6] | 0.097 [2.5] |
| 4 [13] | 0.679 [1.011] | 0.686 [1.021] | 0.500 [12.7] | 0.20 [129] | 1.571 [39.9] | 0.350 [8.9] | 0.020 [0.51] | 0.191 [4.9] | 0.129 [3.3] |
| 5 [16] | 1.048 [1.559] | 1.058 [1.575] | 0.625 [15.9] | 0.31 [199] | 1.963 [49.9] | 0.437 [11.1] | 0.028 [0.71] | 0.239 [6.1] | 0.162 [4.1] |
| 6 [19] | 1.495 [2.225] | 1.511 [2.248] | 0.750 [19.1] | 0.44 [284] | 2.356 [59.8] | 0.525 [13.3] | 0.038 [0.97] | 0.286 [7.3] | 0.194 [4.9] |
| 7 [22] | 2.038 [3.032] | 2.059 [3.064] | 0.875 [22.2] | 0.60 [367] | 2.749 [69.8] | 0.612 [15.5] | 0.044 [1.12] | 0.334 [8.5] | 0.226 [5.8] |
| 8 [25] | 2.685 [3.995] | 2.713 [4.037] | 1.000 [25.4] | 0.79 [510] | 3.142 [79.8] | 0.700 [17.8] | 0.050 [1.27] | 0.383 [9.7] | 0.259 [6.6] |
| 9 [29] | 3.396 [5.053] | 3.441 [5.106] | 1.128 [28.7] | 1.00 [645] | 3.544 [90.0] | 0.790 [20.1] | 0.056 [1.42] | 0.431 [10.9] | 0.292 [7.4] |
| 10 [32] | 4.312 [6.416] | 4.358 [6.484] | 1.270 [32.3] | 1.27 [819] | 3.990 [101.3] | 0.889 [22.6] | 0.064 [1.63] | 0.487 [12.4] | 0.329 [8.3] |
| 11 [36] | 5.296 [7.880] | 5.352 [7.964] | 1.410 [35.8] | 1.56 [1006] | 4.430 [112.5] | 0.987 [25.1] | 0.071 [1.80] | 0.540 [13.7] | 0.365 [9.3] |
| 14 [43] | 7.64 [11.37] | 7.72 [11.49] | 1.693 [43.0] | 2.25 [1452] | 5.32 [135.1] | 1.185 [30.1] | 0.085 [2.16] | 0.648 [16.5] | 0.438 [11.1] |
| 18 [57] | 13.59 [20.22] | 13.72 [20.43] | 2.257 [57.3] | 4.00 [2581] | 7.09 [180.1] | 1.58 [40.1] | 0.102 [2.59] | 0.864 [21.9] | 0.584 [14.8] |

^A The 400 and Duplex-Alloy Series is based on a density of 489.59 lb/ft³ [7833.4 kg/m³]. The 300 Series is based on a density of 494.78 lb/ft³ [7916.5 kg/m³]. Density varies with alloy content which may result in a variation of several percent.

^B The nominal dimensions of a deformed bar are equivalent to those of a round bar having the same weight [mass] per foot [metre] as the deformed bar.

^C The maximum gap (measured as a chord) between the ends of the deformations shall not exceed 25 %/n of the nominal perimeter of the bar, where n is the number of longitudinal gaps or longitudinal ribs around the perimeter of the bar.

1.12 This specification does not purport to address all of the safety concerns, if any, associated with its use. It is the responsibility of the user of this specification to establish appropriate safety, health, and environmental practices and determine the applicability of regulatory limitations prior to use.

1.13 This international standard was developed in accordance with internationally recognized principles on standardization established in the Decision on Principles for the Development of International Standards, Guides and Recommendations issued by the World Trade Organization Technical Barriers to Trade (TBT) Committee.

2. Referenced Documents

2.1 ASTM Standards:²

A6/A6M Specification for General Requirements for Rolled Structural Steel Bars, Plates, Shapes, and Sheet Piling

A342/A342M Test Methods for Permeability of Weakly Magnetic Materials

A370 Test Methods and Definitions for Mechanical Testing of Steel Products

A484/A484M Specification for General Requirements for Stainless Steel Bars, Billets, and Forgings

A751 Test Methods, Practices, and Terminology for Chemical Analysis of Steel Products

A941 Terminology Relating to Steel, Stainless Steel, Related Alloys, and Ferroalloys

C192/C192M Practice for Making and Curing Concrete Test Specimens in the Laboratory

E29 Practice for Using Significant Digits in Test Data to Determine Conformance with Specifications

E290 Test Methods for Bend Testing of Material for Ductility

E527 Practice for Numbering Metals and Alloys in the Unified Numbering System (UNS)

G3 Practice for Conventions Applicable to Electrochemical Measurements in Corrosion Testing

2.2 U.S. Military Standard:³

MIL-STD-129 Marking for Shipment and Storage

2.3 U.S. Federal Standard:³

Fed. Std. No. 123 Marking for Shipment (Civil Agencies)

2.4 AWS Standard:⁴

AWS D1.6/D1.6M Structural Welding Code – Stainless Steel

2.5 SAE Document:⁵

SAE J 1086 Recommended Practice for Numbering Metals and Alloys

3. Terminology

3.1 *Definitions*—For definitions of terms used in this specification, refer to 3.2 and Terminology **A941**.

3.2 *Definitions of Terms Specific to This Specification:*

3.2.1 *deformations, n*—transverse protrusions on a deformed bar.

3.2.2 *deformed bar, n*—steel bar with protrusions; a bar that is intended for use as reinforcement in reinforced concrete construction.

3.2.2.1 Discussion—

The surface of the bar is provided with protrusions that inhibit longitudinal movement of the bar relative to the concrete surrounding the bar in such construction. The protrusions conform to the provisions of this specification.

3.2.3 *plain bar, n*—steel bar without protrusions.

3.2.4 *relative deformation area, n*—the ratio of the deformation bearing area (projected deformation area normal to the bar axis) to the shearing area (nominal bar perimeter times the average spacing of the deformations).

3.2.5 *rib, n*—longitudinal protrusion on a deformed bar.

3.2.6 *three-sided bar, n*—deformed steel bar with three rows of transverse deformations.

3.2.7 *two-sided bar, n*—deformed steel bar with two rows of transverse deformations.

4. Ordering Information

4.1 Orders for stainless steel bars for concrete reinforcement under this specification shall contain the following information

4.1.1 Quantity (weight) [mass],

4.1.2 Deformed or plain,

² For referenced ASTM standards, visit the ASTM website, www.astm.org, or contact ASTM Customer Service at service@astm.org. For *Annual Book of ASTM Standards* volume information, refer to the standard's Document Summary page on the ASTM website.

³ Available from DLA Document Services, Building 4/D, 700 Robbins Ave., Philadelphia, PA 19111-5094, <http://quicksearch.dla.mil>.

⁴ Available from American Welding Society (AWS), 8669 NW 36 St., #130, Miami, FL 33166-6672, <http://www.aws.org>.

⁵ Available from SAE International (SAE), 400 Commonwealth Dr., Warrendale, PA 15096, <http://www.sae.org>.

- 4.1.3 UNS number,
 - 4.1.4 Bar designation number (size) of deformed bars or nominal diameter (size) of plain bars,
 - 4.1.5 Cut lengths or coils,
 - 4.1.6 Grade (strength level), and
 - 4.1.7 ASTM designation A955 [A955M] and year of issue.
- 4.2 The purchaser shall have the option to specify additional requirements, including but not limited to the following:
- 4.2.1 Requirements for inspection (~~19.1~~20.1),
 - 4.2.2 Packaging and package marking (Section 22.23),
 - 4.2.3 Magnetic permeability supplementary requirement (~~S1~~) and (S1),
 - 4.2.4 Controlled mechanical properties supplementary requirement (S2), and
 - 4.2.5 Other special requirements, if any.

5. Materials and Manufacture

5.1 The bars shall be processed from properly identified heats of mold-cast or strand-cast steel. The steel shall be made by any commercially acceptable process.

6. Chemical Composition

- 6.1 The steel shall conform to the requirements for chemical composition specified in [Table 2](#).
- 6.2 The chemical analysis of each heat of steel shall be determined in accordance with Test Methods, Practices, and Terminology [A751](#). The manufacturer shall make the analysis on test samples taken preferably during the pouring of the heat.
- 6.3 The steel shall conform to all applicable chemical composition requirements in Specification [A484/A484M](#).

7. Requirements for Deformations

7.1 Deformations shall be spaced along the bar at substantially uniform distances. The deformations on all sides of the bar shall be similar in size, shape, and pattern.

7.2 The deformations shall be placed with respect to the axis of the bar so that the included angle is not less than 45°. Where the line of deformations forms an included angle with the axis of the bar of from 45 to 70° inclusive, the deformations on a two-sided bar shall alternately reverse in direction on each side or those on one side shall be reversed in direction from those on the opposite side. The deformations on three-sided bars shall reverse on one of the three sides (see [Fig. 1](#)). Where the line of deformation is over 70°, a reversal in direction is not required.

7.3 The average spacing or distance between deformations on each side of the bar shall not exceed seven tenths of the nominal diameter of the bar.

7.4 The overall length of deformations shall be such that the gap (measured as a chord) between the ends of the deformations shall not exceed 25 %/n, where n is the number of longitudinal gaps or longitudinal ribs, of the nominal perimeter of the bar. Where the ends of the deformations terminate in a longitudinal rib, the width of the longitudinal rib shall be considered as the gap between these ends. The summation of the gaps shall not exceed 25 % of the nominal perimeter of the bar. The nominal perimeter of the bar shall be 3.1416 times the nominal diameter.

7.5 The spacing, height, and gap of deformations shall conform to the requirements prescribed in [Table 1](#).

8. Measurement of Deformations

8.1 The average spacing of deformations shall be determined by measuring the length of a minimum of ten spaces and dividing that length by the number of spaces included in the measurement. The measurement shall begin from a point on a deformation at the beginning of the first space to a corresponding point on a deformation after the last included space. Spacing measurements shall not be made over a bar area containing bar marking symbols.

8.2 The average height of deformations shall be determined from measurements made on not less than two typical deformations. Determinations shall be based on three measurements per deformation, one at the center of the overall length and the other two at the quarter points of the overall length.

8.3 For three-sided bars, the relative deformation area, R_d , shall meet the requirements of [Annex A4](#).

8.4 Insufficient height, insufficient circumferential coverage, or excessive spacing of deformations shall not constitute cause for rejection unless it has been clearly established by determinations on each lot ([Note 2](#)) tested that typical deformation height, gap, or spacing does not conform to the minimum requirements prescribed in [Section 7](#). No rejection shall be made on the basis of measurements if fewer than ten adjacent deformations on each side of the bar are measured.

NOTE 2—A lot, for this purpose, is defined as all the bars of one bar number and pattern of deformation contained in an individual shipping release or shipping order.

TABLE 2 Chemical Composition^A

| UNS Designation ^B | Type ^C | Composition % | | | | | | | | | |
|-------------------------------------|--------------------|---------------|-----------|------------|--------|---------|-----------|-----------|------------|-----------|----------------|
| | | Carbon | Manganese | Phosphorus | Sulfur | Silicon | Chromium | Nickel | Molybdenum | Nitrogen | Other Elements |
| Austenitic Grades | | | | | | | | | | | |
| S24000 | XM-29 ^D | 0.08 | 11.5–14.5 | 0.060 | 0.030 | 1.00 | 17.0–19.0 | 2.3–3.7 | | 0.20–0.40 | |
| S24100 | XM-28 ^D | 0.15 | 11.0–14.0 | 0.045 | 0.030 | 1.00 | 16.5–19.0 | 0.50–2.50 | | 0.20–0.45 | |
| S31653 | 316LN | 0.030 | 2.00 | 0.045 | 0.030 | 1.00 | 16.0–18.0 | 10.0–13.0 | 2.00–3.00 | 0.10–0.16 | |
| Austenitic-Ferritic (Duplex) Grades | | | | | | | | | | | |
| S31803 | 2205 ^E | 0.030 | 2.00 | 0.030 | 0.020 | 1.00 | 21.0–23.0 | 4.5–6.5 | 2.5–3.5 | 0.08–0.20 | |
| S32101 | | 0.040 | 4.0–6.0 | 0.040 | 0.030 | 1.00 | 21.0–22.0 | 1.35–1.70 | 0.10–0.80 | 0.20–0.25 | Cu 0.10–0.80 |
| S32205 | 2205 ^D | 0.030 | 2.00 | 0.030 | 0.020 | 1.00 | 22.0–23.0 | 4.5–6.5 | 3.0–3.5 | 0.14–0.20 | |
| S32304 | 2304 ^D | 0.030 | 2.50 | 0.040 | 0.030 | 1.00 | 21.5–24.5 | 3.0–5.5 | 0.05–0.60 | 0.05–0.20 | Cu 0.05–0.60 |

^A Maximum, unless otherwise indicated. Where ellipses (...) appear in this table, there is no requirement and the element need not be determined or reported.

^B Unified Numbering System, UNS, is the designation for a metal or alloy described and established by Practice E527 and SAE J 1086.

^C Unless otherwise indicated, a grade designation originally assigned by the American Iron and Steel Institute (AISI).

^D Naming system developed and applied by ASTM.

^E Common name, not a trademark, widely used in the concrete industry, not associated with any one manufacturer.

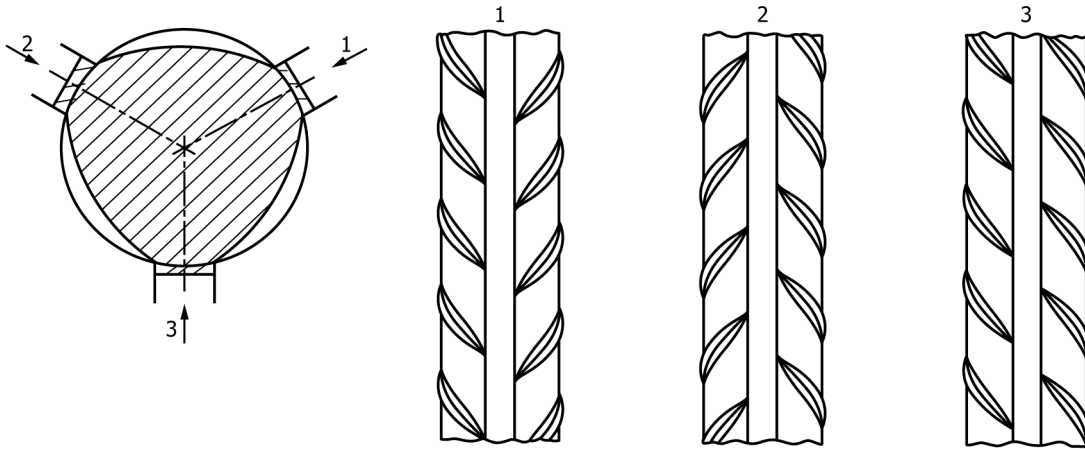

FIG. 1 Typical Three-Sided Deformed Bar

TABLE 3 Tensile Requirements^A

| | Grade 60 [420] | Grade 75 [520] | Grade 80 [550] |
|----------------------------------------------------------------------|-------------------|-------------------|-------------------|
| Tensile strength, min, psi [MPa] | 90 000 [620] | 100 000 [690] | 100 000 [690] |
| Yield strength, min, psi [MPa] | 60 000 [420] | 75 000 [520] | 80 000 [550] |
| Ratio of actual tensile strength to actual yield strength, min | 1.20 | 1.20 | 1.20 |
| Elongation in 8 in. [200 mm], min, % | | | |
| Bar designation no. | | | |
| 3, 4, 5 [10, 13, 16] | 20 | 20 | 16 |
| 6 [19] | 20 | 20 | 16 |
| 7, 8, 9, 10, 11, 14, 18 [22, 25, 29, 32, 36, 43, 57] | 20 | 20 | 16 |

^A Consult with the manufacturer for availability of grades and bar sizes.

TABLE 4 Bend Test Requirements

| Bar Designation No. | Pin Diameter for Bend Test ^A | | |
|-----------------------------|-----------------------------------------|----------------|----------------|
| | Grade 60 [420] | Grade 75 [520] | Grade 80 [550] |
| 3, 4, 5 [10, 13, 16] | 3½d ^B | 3½d | 3½d |
| 6 [19] | 5d | 5d | 5d |
| 7, 8 [22, 25] | 5d | 5d | 5d |
| 9, 10, 11 [29, 32, 36] | 7d | 7d | 7d |
| 14, 18 [43, 57] (90°) | 9d | 9d | 9d |

^A Test bends 180° unless noted otherwise.

^B d = nominal diameter of specimen.

9. Tensile Requirements

9.1 The material, as represented by the test specimens, shall conform to the requirements for tensile properties prescribed in Table 3, and, when required, controlled mechanical properties supplementary requirement (S2). Supplementary Requirement S2 has both a restricted yield strength range and a higher actual tensile strength to actual yield strength ratio.

9.2 The yield strength shall be determined by the offset method (0.2 % offset), as described in Test Methods and Definitions A370.

9.3 When material is furnished in coils, the test specimen shall be taken from the coil and straightened prior to placing it in the jaws of the tensile test machine. Straightening of the test specimens shall be done carefully to avoid formation of local sharp bends and to minimize cold work. (See Note 3.)