



Designation: **C1392 – 00 (Reapproved 2014) C1392 – 20**

## Standard Guide for Evaluating Failure of Structural Sealant Glazing<sup>1</sup>

This standard is issued under the fixed designation C1392; the number immediately following the designation indicates the year of original adoption or, in the case of revision, the year of last revision. A number in parentheses indicates the year of last reapproval. A superscript epsilon ( $\epsilon$ ) indicates an editorial change since the last revision or reapproval.

### 1. Scope

1.1 This guide covers a screening approach to detect failure (adhesive or cohesive) of a structural sealant in a structural sealant-glazed window, curtain wall, or other similar system. Presently, only a silicone-sealant that is specifically formulated, tested, and marketed as a structural glazing sealant is allowed for structural sealant glazing.

1.2 The values stated in either acceptable metric units or in other units shall be regarded separately as the standard. The values stated in each system may not be exact equivalents; therefore, each system must be used independently of the other, without combining values in any way.

1.3 There are no ISO standards similar or equivalent to this ASTM standard.

1.4 *This standard does not purport to address all of the safety concerns, if any, associated with its use. It is the responsibility of the user of this standard to establish appropriate safety, health, and environmental practices and determine the applicability of regulatory limitations prior to use.*

1.5 *This international standard was developed in accordance with internationally recognized principles on standardization established in the Decision on Principles for the Development of International Standards, Guides and Recommendations issued by the World Trade Organization Technical Barriers to Trade (TBT) Committee.*

### 2. Referenced Documents

2.1 ASTM Standards:<sup>2</sup>

**C717 Terminology of Building Seals and Sealants**

### 3. Terminology

3.1 *Definitions:* Refer to Terminology **C717** for the following definitions and description of terms used in this guide: adhesive failure; cohesive failure; deflection; glazing; joint; lite; modulus; silicone sealant; structural sealant; structural sealant glazing; and substrate.

3.1.1 *qualified authority, n*—a person with a recognized degree or professional certificate and extensive knowledge and experience in the particular fields necessary for the evaluation program. The authority's qualification level that is necessary to specify the evaluation criteria and interpret the significance of the results depends upon the level of sophistication of the evaluation program. For example, if statistical and finite element analyses are being incorporated into the evaluation program, then the authority should be knowledgeable and experienced in these areas.

3.1.2 *competent person, n*—a person experienced in the operation of the testing equipment and with an understanding of the construction of the wall system. This person may carry out the field testing under the supervision of the qualified authority.

### 4. Summary of Guide

4.1 This guide uses deflection measurements obtained from localized applied loads to determine locations of sealant failure in an installed structural sealant glazing system.

4.2 Initially, the deflection of an existing lite that is fully adhered by a structural sealant is measured when a discrete edge of the lite is loaded laterally. Subsequently, at a few selected lites, the structural sealant is cut intentionally to simulate failure, and

<sup>1</sup> This guide is under the jurisdiction of ASTM Committee **C24** on Building Seals and Sealants and is the direct responsibility of Subcommittee **C24.10** on Specifications, Guides and Practices.

Current edition approved Jan. 1, 2014/Jan. 1, 2020. Published December 2009/January 2020. Originally approved in 1998. Last previous edition approved in 2009 as **C1392 – 00/C1392 – 09(2009)(2014)**. DOI: 10.1520/C1392-00R14; 10.1520/C1392-20.

<sup>2</sup> For referenced ASTM standards, visit the ASTM website, [www.astm.org](http://www.astm.org), or contact ASTM Customer Service at [service@astm.org](mailto:service@astm.org). For *Annual Book of ASTM Standards* volume information, refer to the standard's Document Summary page on the ASTM website.

the deflection of the lite is measured at the same lateral load. This provides the basis for determining during subsequent tests of other lites in the system whether the sealant has failed.

4.3 Additional lites are evaluated and their deflections measured to determine the extent of any structural sealant failure. Structural sealant failure is determined by comparing the measured deflections with the initial measurements of deflection with and without failed (intentionally cut) sealant.

**5. Significance and Use**

5.1 This guide suggests a simple means of evaluating the extent of any failure of a structural sealant in an installed structural sealant glazing system.

5.2 A qualified authority should specify the criteria described in Sections 8 and 9 and should interpret the results and judge their significance for the structural sealant glazing system.

5.3 The evaluation program measures deflection of loaded lites and does not measure directly any structural sealant failure. Consequently, the qualified authority interpreting the data should also evaluate the source of any increased deflection that is measured. Increased deflection may be due to structural sealant adhesive or cohesive failure, but may also be due to a decrease in sealant modulus, a change in sealant joint dimensions, or other nonfailure mechanisms. Selective destructive sampling of areas with increased deflections can assist in this evaluation.

**6. Suggested Apparatus**

6.1 *Field Loading Device*, provides a frame that can span beyond the edges of the loaded lite, while supported by suction cups on the face of adjacent lites or by other means that do not adversely affect the stresses in the tested structural sealant and lite (Fig. 1 and Fig. 2). To permit application of a force perpendicular to the surface of the lite, mount a loading piston on the lite, with a suction cup or other means near the edge of the lite. Place a load cell between the suction cup and the frame to monitor the applied load. Calibrate the field loading device and the load cell prior to use on a project and immediately after any changes or damage to the device.

6.2 *Deflection Measurement Device*, either an extensometer with a dial gage mounted on an adjacent lite or a straight edge with feeler gages, of length equal to the length of the edge of the lite. The device should be accurate to within 10 % of the measured deflection.

**7. Sampling**

7.1 The qualified authority should specify the locations, distribution, and number of applied loads for the structural sealant glazing system. Sections 8 and 9 discuss various approaches to this selection process.

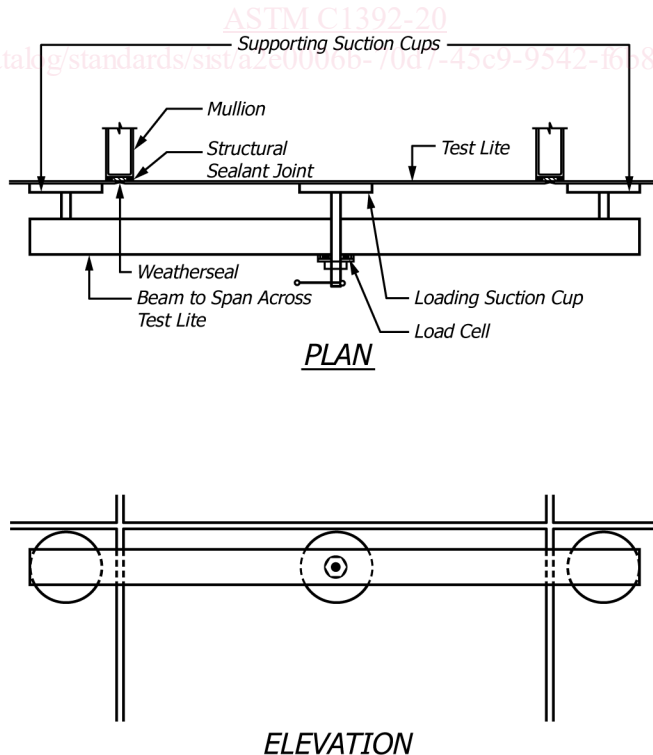

FIG. 1 Schematic of Field Loading Device

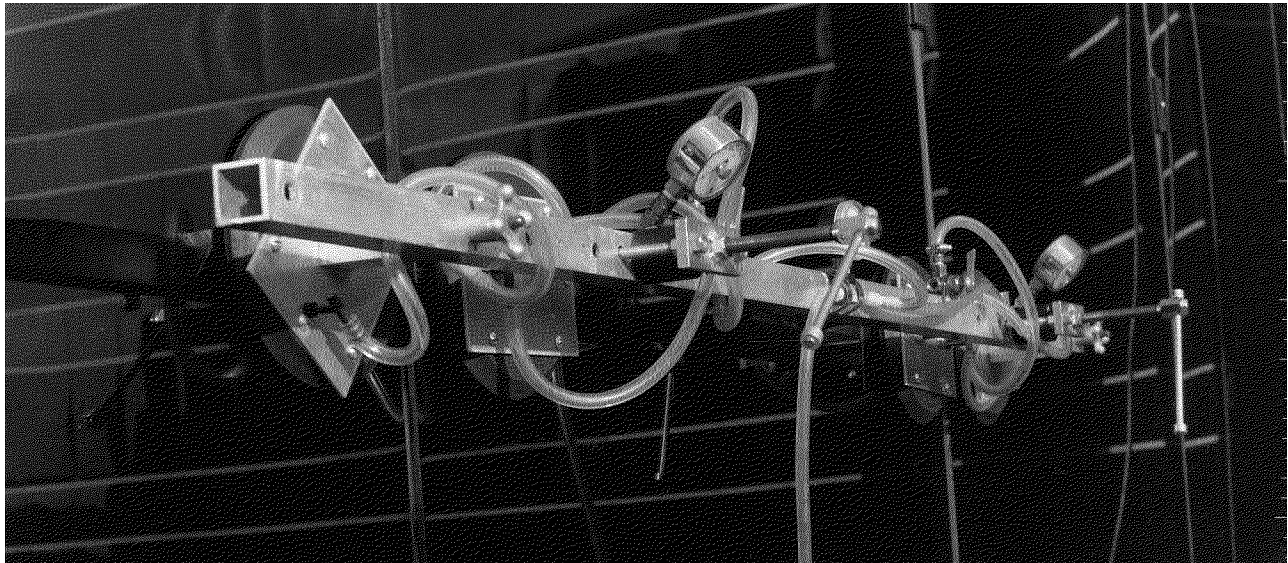

FIG. 2 Example of a Field Loading Device Mounted on a Wall

## 8. Establishing Deflection and Sealant Failure Relationship

8.1 *Summary of Procedure*—Establishing the deflection/failure relationship requires the specifying authority to select the applied load magnitude, the locations of the applied loads on the lite, and the criteria for failure length. The following describes various approaches that can be used to select these parameters, depending upon the sophistication of the evaluation program and the desired results. Depending upon the parameters selected the procedure can be used as a crude screening tool or can be correlated to the actual stresses within the structural sealant joint under an applied load and used as a rational means of assessing areas of failure that require repair. Using the deflection magnitudes and locations, the initial evaluation establishes the relationship between loaded lite deflections with intact structural sealant and those with failed structural sealant.

8.2 *Applied Load Magnitude*—The qualified authority specifies the magnitude of the applied load. The load should be large enough to produce significant differences in deflection between intact and failed sealant areas, that is, the failure length criteria. The applied load can be derived from the glazing system’s lateral design loads through computer modeling (finite element analysis), if it is necessary to relate the testing to a design load and stress.

8.2.1 An initial evaluation will determine whether the applied load is large enough to produce significant differences in deflection between areas with intact structural sealant and those with failed structural sealant. Excessive loads may crack, crack, kink or otherwise damage the glazing material.

8.3 *Applied Load Locations on a Lite*—The evaluation procedure involves application of a local load to a discrete portion of the edge of a lite. Therefore, a single application does not necessarily evaluate a structural sealant joint along the entire edge of a lite. The stress distribution in the structural sealant from the applied load is a function of many variables, including the relative stiffness of the sealant and glazing material, the location of the suction cup, and any resistance from setting blocks or similar items. The qualified authority should specify the extent of testing that is appropriate along each edge of a lite. This determination can be influenced by the degree of assurance that is required from the evaluation program. One approach is to space a number of load application points periodically along the edge of a lite. At close spacings, this approach can evaluate virtually the entire length of the structural sealant joint. However, the duration and cost of such a program can be substantial. Another approach is to make a preliminary study of lites with failure to assist in understanding the failure mechanisms that have occurred and then use this information to select applied load locations in the areas most likely to have failed. For example, initial applied loads may indicate that failure is related to debonding from prolonged contact with water. In this case, evaluation may be performed in the areas likely to collect and trap water against the structural sealant joint, such as the horizontal edges of a lite rather than the vertical edges. If failure is the result of poor substrate cleaning or haphazard or inadequate application of primer, then the failure may be distributed randomly and load applications at the midpoint of each edge may be appropriate.

8.4 *Failure Length Criteria*—The qualified authority should specify the extent of failure that is to be detected. A small, isolated length of failure, such as 2525.4 to 5050.8 mm (1 to 2 in.) for a 66.4 mm (¼ in.) thick glass lite, is difficult to detect, but is not likely to have a significant adverse impact on overall system performance. The length selection can be based on a rational computer analysis of the stresses in the sealant that result from failure and an attempt to keep the stresses below a certain level, such as a 138 KPa (20 psi) structural sealant design stress. In other cases, the failure length selection criteria may be based on detecting the smallest length possible within the accuracy and other parameters of this evaluation program. Detecting a failure length of less than