



Standard Specification for Motorized Treadmills¹

This standard is issued under the fixed designation F2115; the number immediately following the designation indicates the year of original adoption or, in the case of revision, the year of last revision. A number in parentheses indicates the year of last reappraisal. A superscript epsilon (ϵ) indicates an editorial change since the last revision or reappraisal.

INTRODUCTION

The goal of this specification is to promote proper design and manufacturing practices for motorized treadmills. Through these specifications this standard aims to assist designers and manufacturers in reducing the possibility of injury when these products are used in accordance with the operational instructions.

The equipment user must recognize, however, that a standard alone will not necessarily prevent injuries. Like other physical activities, exercise involving fitness equipment involves the risk of injury, particularly if the equipment is used improperly or not properly maintained. In addition, users with physical limitations should seek medical advice or instruction from the fitness facility, or both, prior to using this equipment. Certain physical conditions or limitations may preclude some persons from using this equipment as intended by the manufacturer, and using this equipment may increase the risk of injury.

1. Scope

- 1.1 This specification covers the establishment of parameters for the design and manufacture of motorized treadmills.
- 1.2 It is the intent of this specification to specify products for use by individuals age 13 and above.
- 1.3 This standard is to be used in conjunction with Specification **F2276**, Test Methods **F2571**, and Test Methods **F2106**.
- 1.4 This standard takes precedence over Specification **F2276** and Test Methods **F2571** in areas that are specific to motorized treadmills.
- 1.5 This specification² establishes additional requirements not set forth in the referenced ASTM standards for the design of commercial fitness equipment to increase access and user independence by people with functional limitations or impairments.
- 1.6 The values stated in SI units are to be regarded as the standard. The values given in parentheses are for information only.
- 1.7 *This standard does not purport to address all of the safety concerns, if any, associated with its use. It is the responsibility of the user of this standard to establish appropriate safety, health, and environmental practices and determine the applicability of regulatory limitations prior to use.*
- 1.8 *This international standard was developed in accordance with internationally recognized principles on standardization established in the Decision on Principles for the Development of International Standards, Guides and Recommendations issued by the World Trade Organization Technical Barriers to Trade (TBT) Committee.*

2. Referenced Documents

2.1 ASTM Standards:³

- F1749** Specification for Fitness Equipment and Fitness Facility Safety Signage and Labels
- F2106** Test Methods for Evaluating Design and Performance Characteristics of Motorized Treadmills
- F2276** Specification for Fitness Equipment

¹ This specification is under the jurisdiction of ASTM Committee **F08** on Sports Equipment, Playing Surfaces, and Facilities and is the direct responsibility of Subcommittee **F08.30** on Fitness Products.

Current edition approved ~~June 1, 2018~~ Dec. 1, 2019. Published ~~August 2018~~ January 2020. Originally approved in 2001. Last previous edition approved in ~~2012~~ 2018 as **F2115—12**; **F2115 – 18**. DOI: ~~10.1520/F2115-18~~ 10.1520/F2115-19.

² This work was funded, in part, by the Rehabilitation Engineering Research Center on RecTech through the National Institute on Disability, Independent Living, and Rehabilitation Research grant #90RE5009-01-00.

³ For referenced ASTM standards, visit the ASTM website, www.astm.org, or contact ASTM Customer Service at service@astm.org. For *Annual Book of ASTM Standards* volume information, refer to the standard's Document Summary page on the ASTM website.

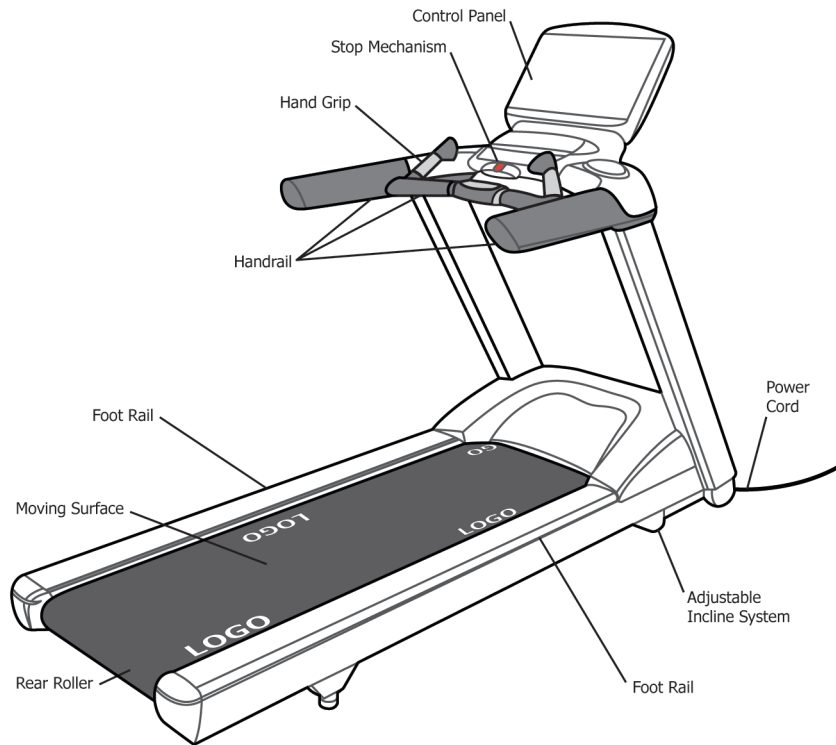

FIG. 1 Treadmill Terminology

F2571 Test Methods for Evaluating Design and Performance Characteristics of Fitness Equipment

F3021 Specification for Universal Design of Fitness Equipment for Inclusive Use by Persons with Functional Limitations and Impairments

2.2 UL Standard:⁴

UL 1647 Motor Operated Massage and Exercise Machines

3. Terminology

3.1 The terms listed below are unique to this specification. For terms not defined below, refer to Specifications F2276 and F3021.

3.2 For treadmill terminology, see Fig. 1.

3.3 Definitions:

3.3.1 *adjustable incline system, n*—components that allow the user to vary the angle of the moving surface relative to the floor.

3.3.2 *control panel, n*—machine/user interface device for controlling the operation of or displaying information about the operational state of the treadmill.

3.3.3 *cycle, n*—refers to one application of load to specifications required in the standard followed by removal of that load.

3.3.4 *deck, n*—component that supports the moving surface.

3.3.5 *emergency stop, n*—device on the treadmill that, when actuated, stops driving the moving surface and lift actuator to stop the treadmill motion in accordance with the deceleration requirements set forth in this specification.

3.3.6 *folding treadmill, n*—treadmill that is designed with some components that can be moved to allow a more compact, non-usable storage position.

3.3.7 *foot rail, n*—area beside the moving surface intended for the user to stand on when mounting or dismounting or during a pause.

3.3.8 *grippable surface, n*—the area of the hand grips intended by the manufacturer to be grasped by the user's hands for balance, stability and/or body weight support during access, egress, and/or exercise.

3.3.9 *hand grips, n*—the intended means that are provided for a user to enhance balance and stability by partially or totally supporting the user's weight with the user's hands or arms.

⁴ Available from Underwriters Laboratories (UL), Corporate Progress, 333 Pfingsten Rd., Northbrook, IL 60062.

3.3.9.1 Discussion—

This may include handrails, handle bars, ergo bars, bull horns and other structural support surfaces.

3.3.10 *longitudinal centerline, n*—the centerline of the treadmill that runs along the direction of travel of the moving surface and splits the unit into equal left and right halves from the user’s perspective when on the unit.

3.3.11 *motorized drive, n*—system that causes motion in the moving surface—utilizing a power source other than the user.

3.3.12 *moving surface, n*—portion of treadmill on which the user walks or runs.

3.3.13 *pull-cord, n*—a cord attached to the emergency stop and designed to be clipped or otherwise attached to the user.

3.3.14 *roller, n*—cylindrical component of the treadmill used to tension or support the moving surface.

3.3.15 *steady state unloaded condition, n*—operational state of the treadmill in which no user or other externally applied load has been applied to the treadmill and the moving surface speed has been allowed to stabilize as commanded by the user interface.

3.3.16 *treadmill, n*—motorized stationary exercise device that allows the user to walk, jog, or run by means of traversing a continuous moving surface.

3.3.17 *user support means, n*—see **hand grips**.

4. Design and Construction Requirements

4.1 *Stability*—The treadmill shall be stable during intended use and storage. Test in accordance with Test Methods F2106.

4.2 *Exterior Design:*

4.2.1 The rear roller of the treadmill shall be designed or guarded to reduce the risk of finger entrapment. The guard or design shall function through the full range of inclination possible and through the full range of belt tension adjustment. The guard configurations shown in Fig. 2 are suggestions that may reduce the risks associated with this area. Fig. 2 assumes that the treadmill is maintained and adjusted per manufacturer’s recommendations.

4.2.1.1 The intention of Fig. 2 is to show some possible alternatives that have been used previously on treadmills to guard the rear roller area. This figure is not intended to limit alternatives that may more effectively address the hazard that is present at the rear roller. The function of the guard is to minimize the possibility of finger entrapment between the roller and the moving surface and between the frame and the end of the roller without introducing an undo tripping hazard to the user of the treadmill.

4.2.2 Electrical elements shall be guarded so as to meet or exceed UL 1647.

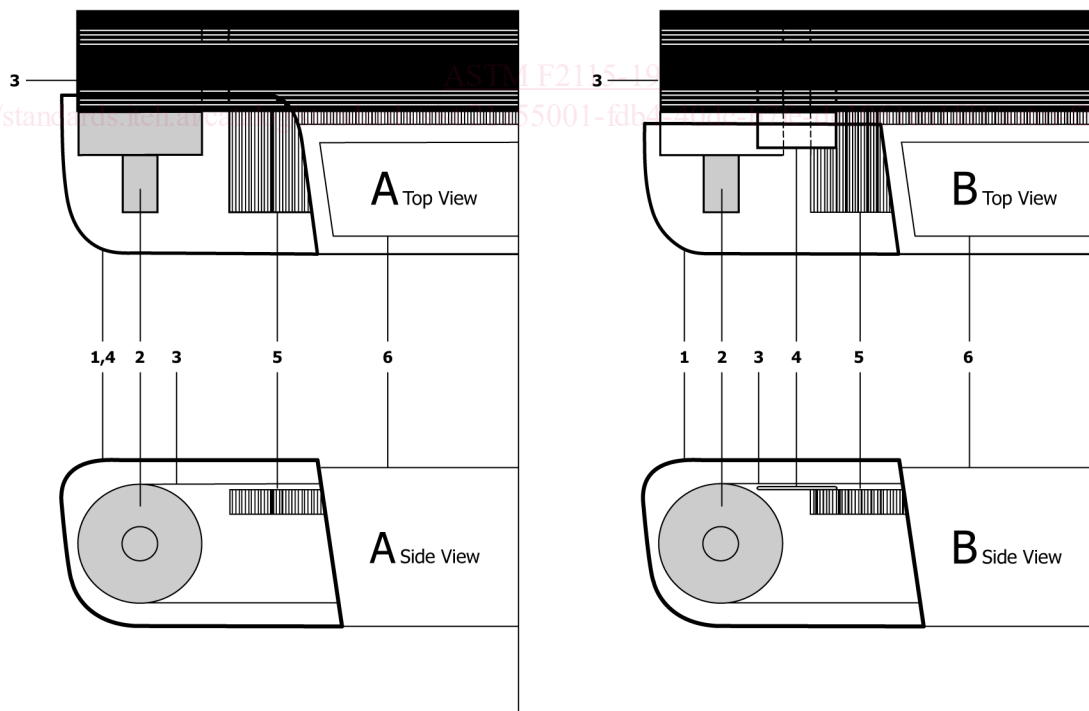

- | | | |
|----------------|----------------------------|------------------|
| 1 End Cap | 2 Rear Roller | 3 Moving Surface |
| 4 Roller Guard | 5 Mounting Surface Support | 6 Foot Rail |

FIG. 2 Examples of Rear Roller Guarding

4.2.3 All treadmills shall be equipped with foot rails to facilitate user mounting and dismounting.

4.2.3.1 Foot rails shall be adjacent to the moving surface and shall extend forward of Line A to either the motor cover or upright masts of the treadmill, and shall extend rearward of Line A to the end caps near the rear roller. See Fig. 3.

4.2.3.2 For foot rail lateral spacing of 950 mm (37.4 in.) or less, the minimum foot rail surface width dimension shall be 75 mm (2.9(3.0 in.)). For foot rails spaced greater than 950 mm (37.4 in.), the minimum foot rail surface width dimension shall be 150 mm (5.9 in.). See Fig. 3.

4.2.4 *Moving Surface*—On institutional treadmills, visual movement markings shall be provided on the moving surface. These markings shall be permanently affixed to, or be part of, the moving surface. These markings shall be of a contrasting color to the rest of the moving surface. A portion of these markings shall always be visible when the moving surface is in operation. The markings shall be a minimum width of 50 mm (2.0 in.) by a minimum 150 mm (5.9 in.) in length. Between two markings a minimum space the size of one marking shall be provided. See Fig. 4.

4.2.5 *Moving Surface Slip Resistance*—The moving surface shall be constructed to minimize foot slippage.

4.2.6 *Hand Grips and Grippable Surfaces:*

4.2.6.1 Institutional and consumer treadmills that can support ~~speeds~~ speeds above 5.0 km/h (3.1 mph) shall be equipped with grippable surfaces to enhance stability and provide support to the user. Grippable surfaces shall comply with Specification F2276 hand grip non-slip specifications.

4.2.6.2 Grippable surfaces shall each have a minimum continuous length of 175 mm (6.9 in.).

4.2.6.3 Institutional and consumer treadmills shall have grippable surfaces located symmetrically about the longitudinal centerline of the treadmill. At least two symmetrically located grippable surfaces, each of minimum continuous length, shall be located entirely within 480 mm (18.9 in.) of the longitudinal centerline of the unit.

4.2.6.4 At least the top surfaces of two symmetrically located grippable surfaces, each of minimum continuous length, shall be located between horizontal planes P1 and P2 when the treadmill is set to its minimum incline position. See 4.2.6.4(1) for procedure for defining horizontal planes P1 and P2. At least two symmetrically located grippable surfaces, each of minimum continuous length, shall be located between horizontal planes P3 and P4 when treadmill is set to its maximum incline position. See 4.2.6.4(1) for procedure for defining horizontal planes P3 and P4 (see Figs. 5 and 6).

(1) *Procedure for Defining Horizontal Planes P1, P2, P3, and P4 for Evaluating Grippable Surface Height Requirements*—First, determine the position of a reference line, Line A, on top of the moving surface of the treadmill by referring to Fig. 3. Define the usable moving surface on the treadmill in the following way: Define a rectangle centered on the longitudinal centerline of the treadmill that is the minimum width as defined in Table 1, where the rear edge of the rectangle is located at the top tangent line of the rear roller, and where the front edge of the rectangle is located as far forward on the treadmill as possible without the rectangle encountering anything other than the moving surface (excluding rear roller guards). The rectangle defines the usable moving area of the treadmill, and the length of this rectangle is length L. Define Line A as a line on top of the moving surface that is located a distance L/3 rearward from the front edge of the rectangle.

4.2.6.5 Each grippable surface shall withstand a vertical load of 1.0x the maximum user weight specified by the manufacturer or 135 kg (297.6 lb), whichever is greater, without breakage. The test load shall be distributed equally between the two grippable surfaces.

4.3 *Endurance Loading:*

4.3.1 Treadmills shall function per manufacturer’s specifications after endurance loading as follows:

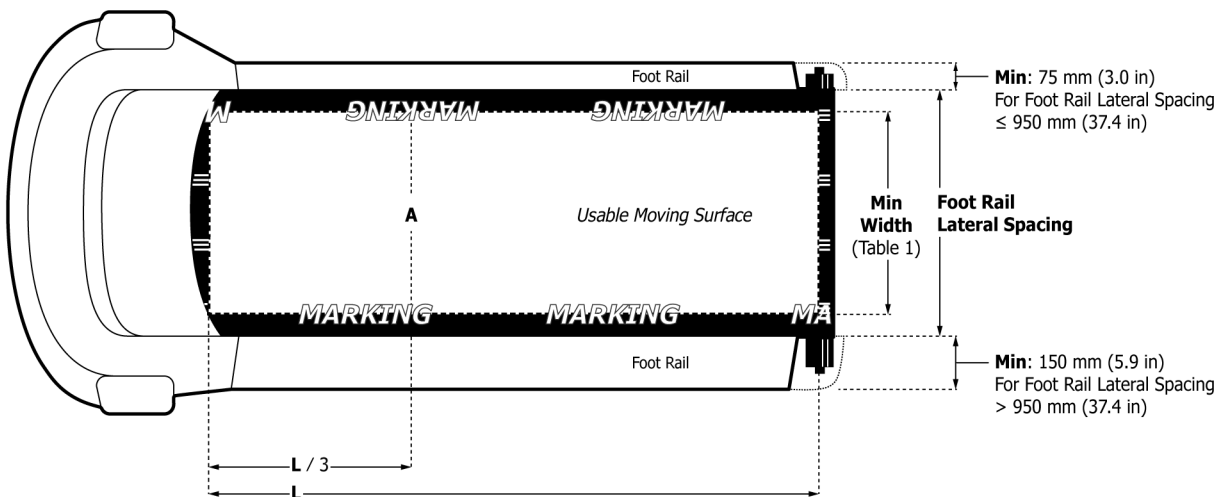

FIG. 3 Top View of Required Foot Rail Dimensions

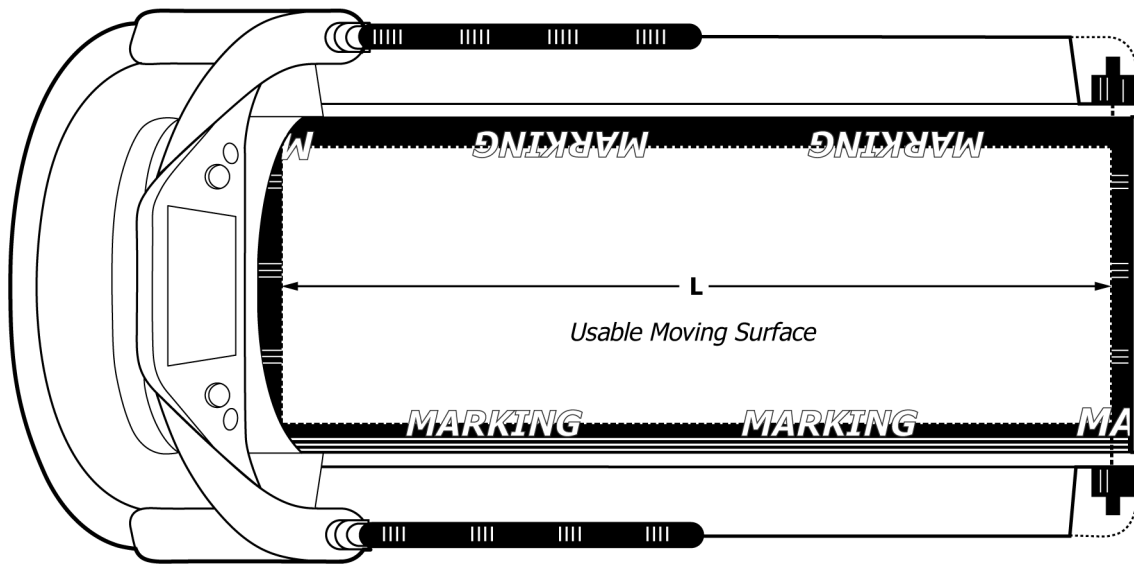
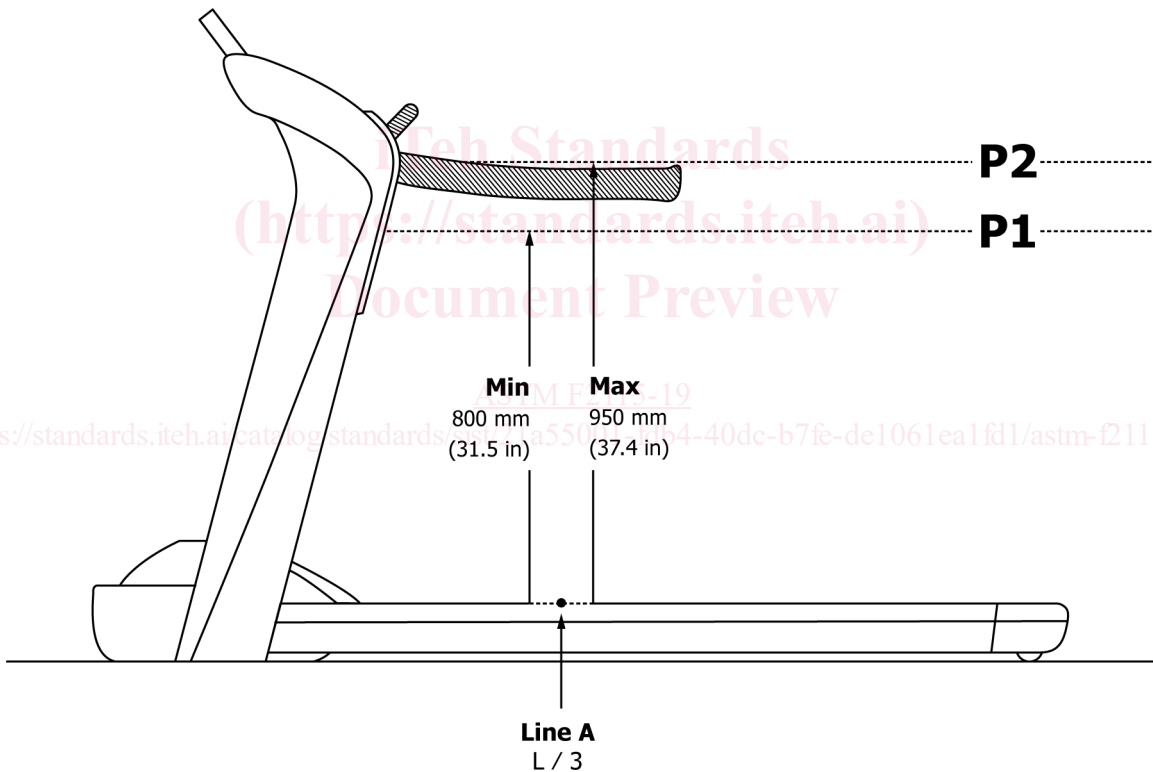

FIG. 4 Example of Color Value Contrast on Treadmill Belt/Deck and Handrail Length Belt



NOTE 1—With the treadmill at its minimum incline position, define a first horizontal plane P1 measured 800 mm (31.5 in.) above Line A, and define a second horizontal plane P2 measured 950 mm (37.4 in.) above Line A.

FIG. 5 Reference Plane Locations When Treadmill is at its Minimum Incline Position

4.3.1.1 *Consumer Treadmills*—2 cycles/s × 3600 s/h × 1 h usage/week × 52 weeks = 375 000 cycles minimum applied to the stationary moving surface at a load equal to 1.5× the maximum specified user weight.

4.3.1.2 *Institutional Treadmills*—2 cycles/s × 3600 s/h × 7 h usage/week × 52 weeks = 2 620 000 cycles minimum applied to the stationary moving surface at a load equal to 1.5× the maximum specified user weight.

4.3.2 Switches and switch actuation mechanisms for controlling the stop, pause, or end functions shall function properly as follows:

4.3.2.1 *Consumer Treadmills*—3 times/h × 5 h/week × 52 weeks/year × a safety factor of 2 = 1560 actuations.

4.3.2.2 *Institutional Treadmills*—3 times/h × 50 h/week × 52 weeks/year × 3 years × a safety factor of 2 = 46 800 actuations.

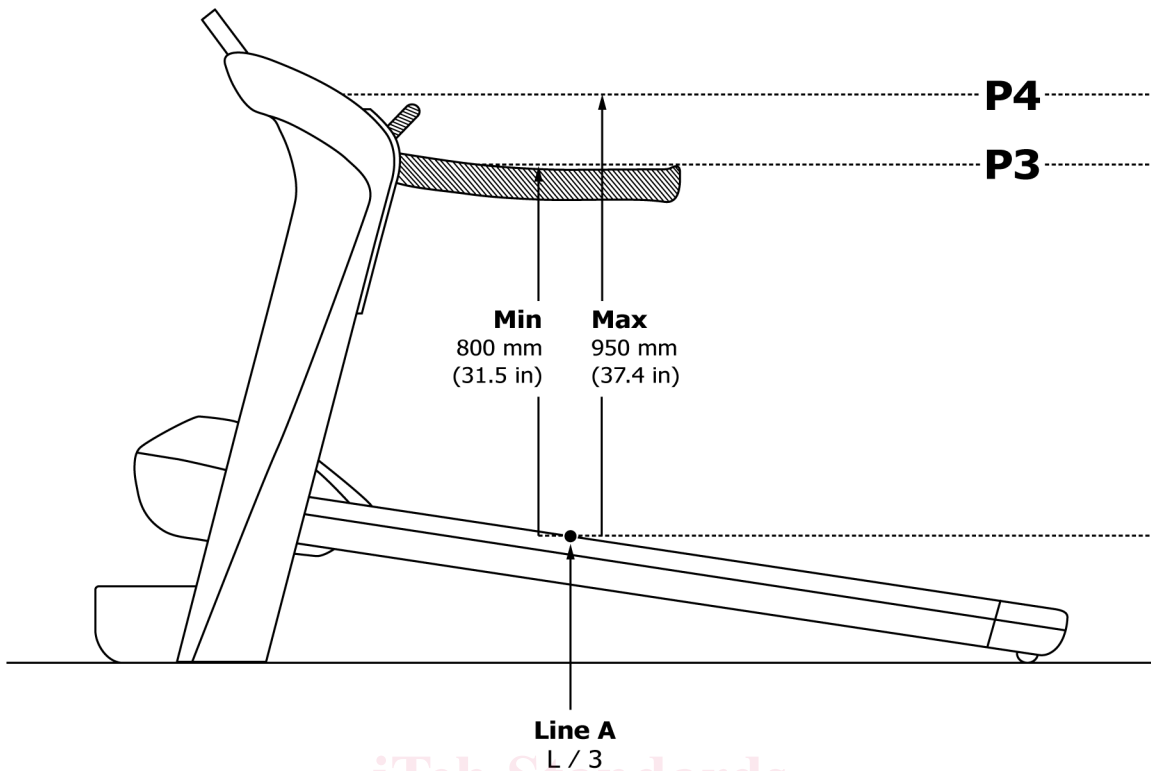

NOTE 1—With the treadmill at its maximum incline position, define a third horizontal plane P3 measured 800 mm (31.5 in.) above Line A, and define a fourth horizontal plane P4 measured 950 mm (37.4 in.) above Line A.

FIG. 6 Reference Plane Locations When Treadmill is at its Maximum Incline Position

TABLE 1 Minimum Dimensions of the Usable Moving Surface

For Institutional Treadmills		
Maximum Speed	Minimum Width	Minimum Length
0 to 9.7 kph (0 to 6 mph)	400 mm (15.8 in.)	815 mm (32.1 in.)
>9.7 to 13 kph (>6 to 8.1 mph)	400 mm (15.8 in.)	965 mm (38 in.)
>13 to 16 kph (>8.1 to 9.9 mph)	400 mm (15.8 in.)	1090 mm (42.9 in.)
>16 kph (>9.9 mph)	400 mm (15.8 in.)	1270 mm (50 in.)
For Consumer Treadmills		
Maximum Speed	Minimum Width	Minimum Length
0 to 9.7 kph (0 to 6 mph)	325 mm (12.8 in.)	815 mm (32.1 in.)
>9.7 to 13 kph (>6 to 8.1 mph)	350 mm (13.8 in.)	965 mm (38 in.)
>13 to 16 kph (>8.1 to 9.9 mph)	350 mm (13.8 in.)	1090 mm (42.9 in.)
>16 kph (>9.9 mph)	400 mm (15.8 in.)	1270 mm (50 in.)

4.4 *Static Loading*—The moving surface and deck (if present) shall withstand a load equal to 4× maximum specified user weight for institutional treadmills and 2.5× maximum specified user weight for consumer treadmills without breakage. The foot rails shall withstand a load equal to 2× the maximum specified user weight without breakage.

4.5 *Adjustable Incline System*—The adjustable incline system, if the treadmill is so equipped, shall not move in excess of 25 mm/s (1 in./s) measured at any pinch or shear point created by the movement of the incline system.

4.6 *Controls:*

4.6.1 A motorized treadmill shall be equipped with at least one emergency stop.

4.6.1.1 Emergency stops shall be actuated by a push-button or a pull-cord.

4.6.1.2 ~~Emergency stops shall be positioned to be easily actuated by the user or a third party, or both. All mechanically operated safety stops, including tether/pull cord or similar, shall be located within reach accessible by a user or by a third party, and shall be accessible from both the exercise position and from either side of the treadmill by a third party, treadmill, in a clear line of sight, sight and located in front of the user, with no physical obstruction to interfere with access from the center, left, or right.~~

NOTE 1—Handrails or other necessary structure will not be considered a physical obstruction.

4.6.1.3 Upon emergency stop activation, the moving surface shall decelerate to a stop.

4.6.1.4 Upon reset of the emergency stop the incline shall return to 0 %.