



Designation: **D7421—16 D7421 – 19**

Standard Test Method for Determining Extreme Pressure Properties of Lubricating Oils Using High-Frequency, Linear-Oscillation (SRV) Test Machine¹

This standard is issued under the fixed designation D7421; the number immediately following the designation indicates the year of original adoption or, in the case of revision, the year of last revision. A number in parentheses indicates the year of last reappraisal. A superscript epsilon (ϵ) indicates an editorial change since the last revision or reappraisal.

1. Scope*

1.1 This test method covers a procedure for determining extreme pressure properties of lubricating oils for hydraulics, gears, and engines under high-frequency linear-oscillation motion using the SRV test machine.

NOTE 1—This test method was developed and the international round robin tests were jointly performed with the DIN 51834 working group. This procedure is based on the 2005 revision of Test Method D5706 for greases and differs regarding the stroke length and the cleaning solvent.

1.2 The values stated in SI units are to be regarded as standard. No other units of measurement are included in this standard.

1.3 *This standard does not purport to address all of the safety concerns, if any, associated with its use. It is the responsibility of the user of this standard to establish appropriate safety, health, and environmental practices and determine the applicability of regulatory limitations prior to use.*

1.4 *This international standard was developed in accordance with internationally recognized principles on standardization established in the Decision on Principles for the Development of International Standards, Guides and Recommendations issued by the World Trade Organization Technical Barriers to Trade (TBT) Committee.*

2. Referenced Documents

2.1 *ASTM Standards:*²

[A295/A295M Specification for High-Carbon Anti-Friction Bearing Steel](#)

[D217 Test Methods for Cone Penetration of Lubricating Grease](#)

[D235 Specification for Mineral Spirits \(Petroleum Spirits\) \(Hydrocarbon Dry Cleaning Solvent\)](#)

[D4175 Terminology Relating to Petroleum Products, Liquid Fuels, and Lubricants](#)

[D5706 Test Method for Determining Extreme Pressure Properties of Lubricating Greases Using a High-Frequency, Linear-Oscillation \(SRV\) Test Machine](#)

[E45 Test Methods for Determining the Inclusion Content of Steel](#)

[G40 Terminology Relating to Wear and Erosion](#)

2.2 *DIN Standards:*³

[DIN 51631:1999–04 Mineral spirits; special boiling point spirits; requirements](#)

[DIN EN ISO 683-17 Heat-treated Steels, alloy steels and free-cutting steels—Part 17 : Ball and roller bearing steels \[Replaces DIN 17230-1980\]](#)

[DIN EN ISO 13565-2:1998 Geometrical Product Specifications \(GPS\)—Surface texture: Profile method; Surfaces having stratified functional properties—Part 2: Height characterization using linear material ratio curve \[Replacement of DIN 4776:1990: Measurement of surface roughness; parameters \$R_K\$, \$R_{PK}\$, \$R_{VK}\$, \$M_{r1}\$, \$M_{r2}\$ for the description of the material portion\]](#)

3. Terminology

3.1 *Definitions:*

¹ This test method is under the jurisdiction of ASTM Committee D02 on Petroleum Products, Liquid Fuels, and Lubricants and is the direct responsibility of Subcommittee D02.L0.11 on Tribological Properties of Industrial Fluids and Lubricates.

Current edition approved Oct. 1, 2016 Dec. 1, 2019. Published February 2017 January 2020. Originally approved in 2008. Last previous edition approved in 2014 as D7421—14; D7421 – 16. DOI: 10.1520/D7421-16.10.1520/D7421-19.

² For referenced ASTM standards, visit the ASTM website, www.astm.org, or contact ASTM Customer Service at service@astm.org. For *Annual Book of ASTM Standards* volume information, refer to the standard's Document Summary page on the ASTM website.

³ Available from Beuth Verlag GmbH (DIN, Deutsches Institut für Normung e.V.), Burggrafenstrasse 6, 10787, Berlin, Germany, <http://www.en.din.de>.

*A Summary of Changes section appears at the end of this standard

3.1.1 *break-in, n—in tribology*, an initial transition process occurring in newly established wearing contacts, often accompanied by transients in coefficient of friction or wear rate, or both, which are uncharacteristic of the given tribological system's long-term behavior. **G40**

3.1.2 *coefficient of friction, μ or $f, n—in tribology$* , the dimensionless ratio of the friction force (F) between two bodies to the normal force (N) pressing these bodies together. **G40**

3.1.3 *Hertzian contact area, n*—apparent area of contact between two nonconforming solid bodies pressed against each other, as calculated from Hertz's equations of elastic deformation published in 1881. **G40**

3.1.4 *Hertzian contact pressure, n*—magnitude of the pressure at any specified location in a Hertzian contact area, as calculated from Hertz's equations of elastic deformation. The Hertzian contact pressure can also be calculated and reported as maximum value P_{\max} in the centre of the contact or as P_{average} as average over the total contact area. **D4175**

3.1.5 *lubricant, n*—any material interposed between two surfaces that reduces the friction or wear, or both between them. **D4175D217**

3.1.6 *Ra (C.L.A.), n—in measuring surface finish*, the arithmetic average of the absolute distances of all profile points from the mean line for a given distance.⁴

⁴ Amstutz, Hu, "Surface Texture: The Parameters," Bulletin MI-TP-003-0785, Sheffield Measurement Division, Warner and Swasey, 1985.

3.1.6.1 Discussion—

C.L.A. means center line average, and it is the synonym to Ra.

3.1.7 *Rpk, n*—Reduced peak height according to DIN EN ISO 13565-2:1998. Rpk is the mean height of the peak sticking out above the core profile section.

3.1.8 *Rvk, n*—Reduced valley height according to DIN EN ISO 13565-2:1998. Rvk is the mean depth of the valley reaching into the material below the core profile section.

3.1.9 *Rz (DIN), n—in measuring surface finish*, the average of all R_y values (peak to valley heights) in the assessment length.⁴

3.2 Definitions of Terms Specific to This Standard:

3.2.1 *extreme pressure, adj—in lubrication*, characterized by metal surfaces in contact under high-stress rubbing conditions. It is not limited to metallic materials.

3.2.2 *seizure, n*—localized fusion of metal between the rubbing surfaces of the test pieces. **D5706**

3.2.2.1 Discussion—

In this test method, seizure is indicated by a sharp rise in the coefficient of friction, over steady state, of >0.2 for over 20 s. In severe cases, a stoppage in the motor will occur. (These criteria were believed to be right, because this test method is related to liquid lubricants.)

3.3 Abbreviations:

3.3.1 *SRV, n*—Schwingung, Reibung, Verschleiß (German); oscillating, friction, wear (English translation).

4. Summary of Test Method

4.1 This test method is performed on an SRV test machine using a steel test ball oscillating against a stationary steel test disk with lubricant between them. Test load is increased in 100 N increments until seizure occurs. The load, immediately prior to the load at which seizure occurs, is measured and reported as O.K.-load, which can be converted in Hertzian contact pressures.

NOTE 2—Test frequency, stroke length, temperature, and ball and disk material can be varied to simulate field conditions. The test ball yields point-contact geometry. To obtain line or area contact, test pieces of differing configurations can be substituted for the test balls.

NOTE 3—With regard to the test chamber and the operating conditions, SRV models III, IV, and V are identical. However, the SRV IV and V allow to incline the axis of movement. Both models are fully computer controlled. In SRV IV and V models, the test described here is run horizontally and without inclination. SRV I and II models can also perform this test, but they are limited with regard to maximum load and stroke. As modern and high performance oils may exceed an O.K.-load of 1200 N, seizure may not be reached. Optimol Instruments supplies an upgrade kit to allow for SRV I and SRV II models to be operated at 1600 N, if needed. SRV III test machines after 1995 reach 2000 N. SRV IV and SRV V models can be equipped with a maximum test load unit of 2500 N.

5. Significance and Use

5.1 This laboratory test method can be used to quickly determine extreme pressure properties of lubricating oils at selected temperatures specified for use in applications where not only high-speed vibrational or start-stop motions are present with high Hertzian point contact. This test method has found wide application in qualifying lubricating oils used in constant velocity joints



FIG. 1 SRV Test Machine (Model III)

of front-wheel-drive automobiles, gear-hydraulic circuit, rear axles, gears and engine components. Users of this test method should determine whether results correlate with field performance or other applications.

6. Apparatus

6.1 *SRV Test Machine*,⁵ illustrated in Figs. 1-4.

6.2 *Test Balls*,⁵ 52100 steel, 60 HRC \pm 2 HRC hardness, 0.025 μm \pm 0.005 μm Ra surface finish, 10 mm diameter.

6.3 *Lower Test Disk*, vacuum arc remelted (VAR) AISI 52100 steel with a inclusion rating using Method D, Type A, and a severity level number of 0.5 according to Specification A295/A295M or Test Methods E45 or an inclusion sum value $K1 \leq 10$ in accordance with DIN EN ISO 683-17 and spheroidized annealed to obtain globular carbide, 60 HRC \pm 2 HRC hardness, with the surfaces of the disk being lapped and free of lapping raw materials. The topography of the disk will be determined by four values, 24 mm \pm 0.5 mm diameter by 7.85 mm \pm 0.1 mm thick:

$0.50\text{--}0.500 \mu\text{m} < R_z \text{ (DIN)} < 0.650 \mu\text{m}$

$0.035 \mu\text{m} < \text{C.L.A. (Ra)} < 0.050 \mu\text{m}$

$0.020 \mu\text{m} < R_{pk} < 0.035 \mu\text{m}$

$0.050 \mu\text{m} < R_{vk} < 0.075 \mu\text{m}$

7. Reagents and Materials

7.1 *Cleaning Solvent*—single boiling point spirit type 2-A according to DIN 51631:1999 (published in English). (**Warning**—Flammable. Health hazard.)

NOTE 4—In the case of unavailability, please refer to Specification D235 regarding Type I, Class C (with less than 2 % by volume of aromatics), mineral spirits.

8. Preparation of Apparatus

Preparation of SRV III, SRV IV, and SRV V Models

8.1 When using SRV III, SRV IV, and SRV V models, clean and install the specimens as specified under 9.1 to 9.7. Turn on the test machine and the PC and allow to warm up for 15 min prior to running tests.

8.2 Create a set point profile in the SRV control software with the following parameters:

NOTE 5—Depending on the software version, names and availability of the parameters can vary.

8.2.1 Start conditions:

Temperature: for example, 50 °C \pm 1 K or 80 °C \pm 1 K or 120 °C \pm 1 K

Test load: 50 N \pm 1 N

Start delay: 300 s (is displayed by all versions of the SRV software).

8.2.2 Cut-off criteria for friction:

⁵ The sole source of supply of the apparatus known to the committee at this time is Optimol Instruments GmbH, Westendstr. 125, D-80339 Flöbergasse 3, D-81369 Munich, Germany. If you are aware of alternative suppliers, please provide this information to ASTM International Headquarters. Your comments will receive careful consideration at a meeting of the responsible technical committee,¹ which you may attend.

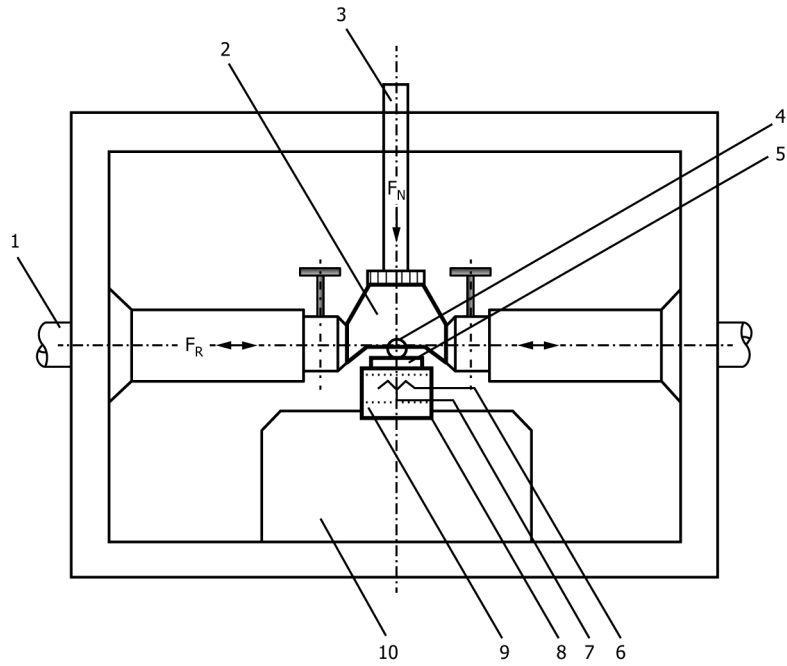

- 1. Oscillation drive rod
- 2. Test Ball Holder
- 3. Load Rod
- 4. Test Ball
- 5. Test Disk

- 6. Electrical Resistance Thermometer
- 7. Resistance Thermometer
- 8. Test Disk Holder
- 9. Piezoelectric Measuring Device
- 10. Receiving Block

FIG. 2 Test Chamber Elements of SRV III



FIG. 3 SRV Test Machine (Model IV)

Coefficient of friction, f (cut-off value for permanent increase of level):
 0.3 during $t > 20$ s
 Coefficient of friction, f (cut-off value for one-off increase of level): 0.35